

F9J €€ B`J`

: ÷ "(
 G5B85F8 HFC1 : <'<C @
 fG<C K B. 9<: !%%\$!\$%LL!8L
 fG5A 95G: ÷ "%Z! B @GGC H: 9FK @9 GH5H8L

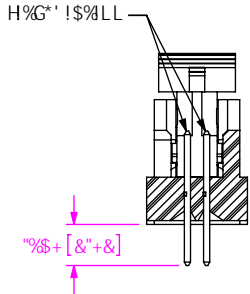

G97 HC B `6`1`6`

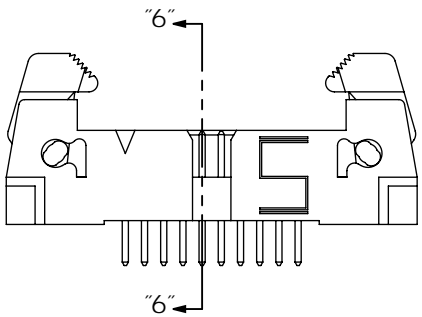
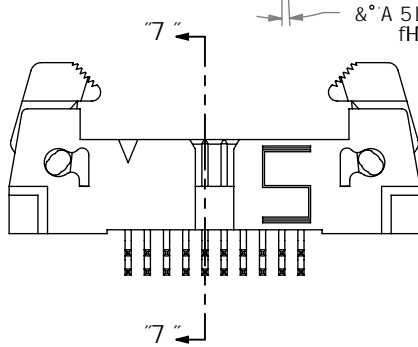
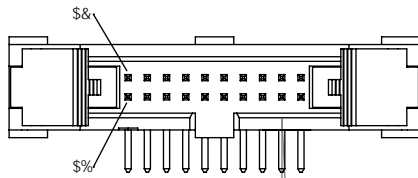

7"

: ÷ "(
 IF5. F ÷ <H5B: @C DHC B
 fG<C K B. 9<: !%%\$!\$%LL!8L!F5L
 fG5A 95G: ÷ "%Z! B @GGC H: 9FK @9 GH5H8L

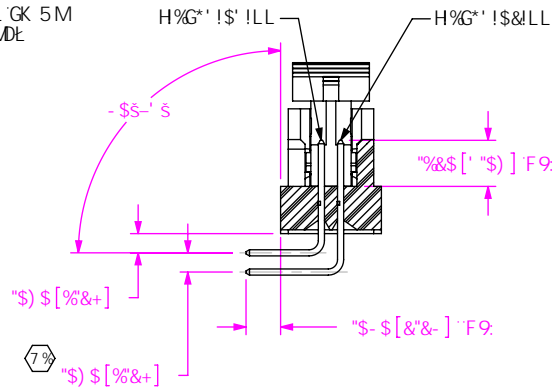

G97 HC B `7`1`7`

D57?5; B; J 9K G

f@C 58 D5FHGK H: DC GHC B : %B8-7 5HC F
 B G5A 98 F97 HC B 5G5FFC K C B H 69L

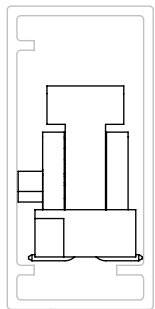

DH%&(1\$%) %

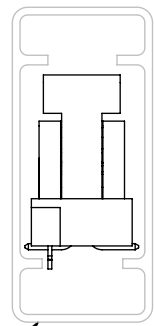

DH%&(1%&-

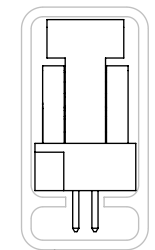

DH%&(1\$)!\$-

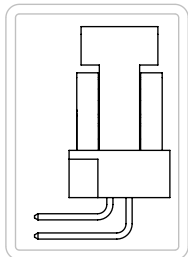

DH%&(1\$%) &

!F5 `B!DFC 7 9GG%

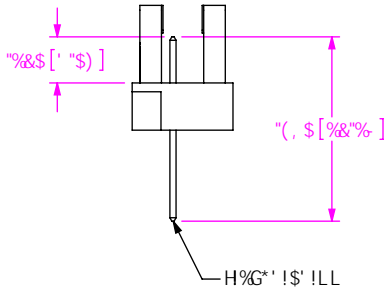

!F5 `B!DFC 7 9GG&

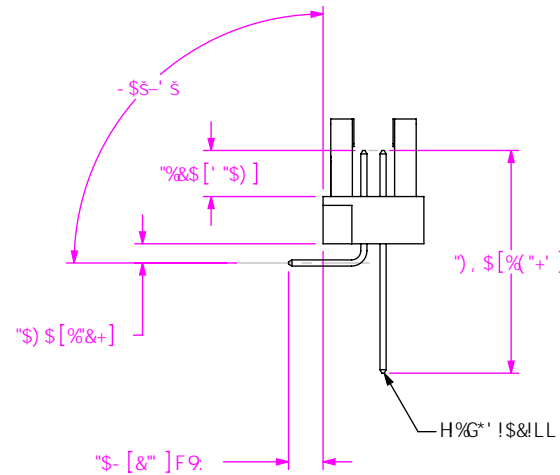

TAIL OPTION	OPTION	PACKAGING TUBE	PLUG
THROUGH HOLE	N/A	PT-1-24-05-09	TP-07
-SM	NONE, -LC, -K, -LC-K	PT-1-24-16-29	
-SM	-P, -LC-P	PT-1-24-01-51	TP-13
-RA	N/A	PT-1-24-01-52	

DFC.DF-9H5FMBC H9
 H: 6BC 71A 98H7 C B16 BG B: C FA 5HC B
 7 C B: @98H5 95B8 DFC DF 945 F H M C
 G5A H97 2 87 588 G: 588BC H69 F90FC 81 7 98
 C F H F58G 9F 98 HC C H: 9F 8C 71A 98HC F
 8 47 @C 98H C C H: 9FGC F 1 98: C F 58M
 DI FDC 09 C H: 9F H: 5B H: 5HK <7 < H K 5G
 C 616 B 98 K H: C 1 H H: 9 9 L DF 9098 K F H 68
 7 C B 98 HC: G5A H97 2 87 "

8C `BCH G7 5 @9 8F5K B:

G: 99HG7 5 @9 & %

: .PBK : PA 67 PA 7H P9<: !%LL!\$%LL!8L!LL!LL!LL!L?HG@88FK



) & \$ D5F? 95GH6@ 82B9K 5 @5BM B (+) \$
 D<C B 9; %&L - ((! * + SL; %&L - () \$ (+
 YIA UJ; .b z 4 G5A H97 Wc a Wc XY.)) &&

89G7 F @HC B.
 "\$) \$ 9>7 HC F < 95 8 9F 5G9A 6 @M

8K : "BC"
 9<: !%LL!\$%LL!8L!LL!LL!LL

6M 9F 7 A " \$, #%+ # \$ % G< 99H & C : '

IGA : G I F: 5 7 9 A C I BHC DHC B
fG<C K B : 9<: !%\$!\$%LL!8!GA !@7 Ł

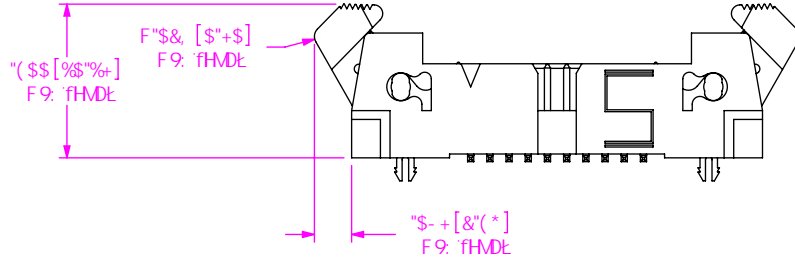

!\$' / !\$('D=7 ? 5B8 D@5 7 9 D5 8
fG<C K B : 9<: !%\$(! \$%LL! 8 ! GA ! LL! DŁ

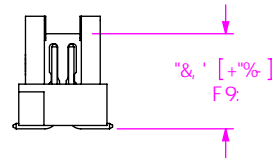
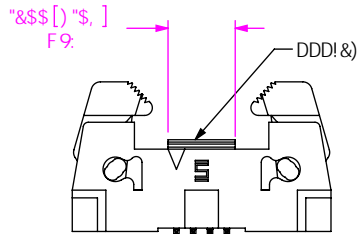

@H7 <9G CA #H8 : C F 7 @5 F #M

DFC.DF-915 FMBC H9
H: €9C 7 I A 98H7 C B I B G B : C F A 5HC B
7 C B : @98H5 @5B8 DFC DF 945F HMC
GSA H97 2 8 7 * 5B8 G-5 @BHC H69 F90FC 81 7 98
CF HF5B8 G 9F98 HC C H: 9F 8C 7 I A 98H6 C F
8 47 @C 98H C C H: 9F G C F I 98 : C F 5B M
DI FDC @9 C H: 9F H: 5B H: 5HK < 7 < #HK 5 G
C 6H5 B 98 K #< C I H: 9 9 L DF 9098 K F #H8
7 C B G 98 HC : GSA H97 2 8 7 *

8C 'BCH G7 5 @9 8F5K #B:

G: 99HG7 5 @9 & %



)&\$ D5F? '95 GH6@ 8zB9K '5 @5B M' B '(+) \$
D<C B 9 , %& L - ((! * + ' ; : & ' , %& L - (, !) \$ (+
Y I A U J :) & z : 4 G S A H 9 7 ' W c a ' W e X Y .))' & &

89G7 F @HC B :
"\$) \$ '9>97 HC F ' < 95 8 9F ' 5G9A 6 @M

8K : "BC"
9<: !%LL!\$%LL!8!LL!LL!LL

6M 9F 7 ' A " \$, # % + # \$ % G< 99H ' " C : ' ' "