

THIS DOCUMENT CONTAINS DATA PROPRIETARY TO PROJECTS UNLIMITED, INC. ANY USE OR REPRODUCTION, IN ANY FORM, WITHOUT PRIOR WRITTEN PERMISSION OF PROJECTS UNLIMITED, INC. IS PROHIBITED.
 © 2005, Projects Unlimited Inc.

SPECIFICATIONS

PARAMETERS	VALUES	UNITS
RATED VOLTAGE	24	Vdc
OPERATING VOLTAGE RANGE	9 ~ 28	Vdc
TONE OUTPUT	SEE 32 TONE CHART	-
RATED CURRENT	18	mA
INGRESS PROTECTION	IP33	-
COLOR	RED	-
OPERATING TEMPERATURE	-25 ~ +70	°C
HOUSING MATERIAL	ABS	-
TERMINAL	SCREW	-
WEIGHT	109	grams

REVISIONS			
LTR	DESCRIPTION	DATE	APPROVED
-	RELEASED FROM ENGINEERING	9/7/06	
A	ADDED RoHS & BASE NOTES	5/21/07	R.W.

DETAIL "A"

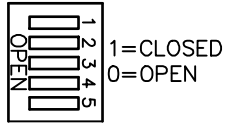

DETAIL "B"

VOLUME CONTROL

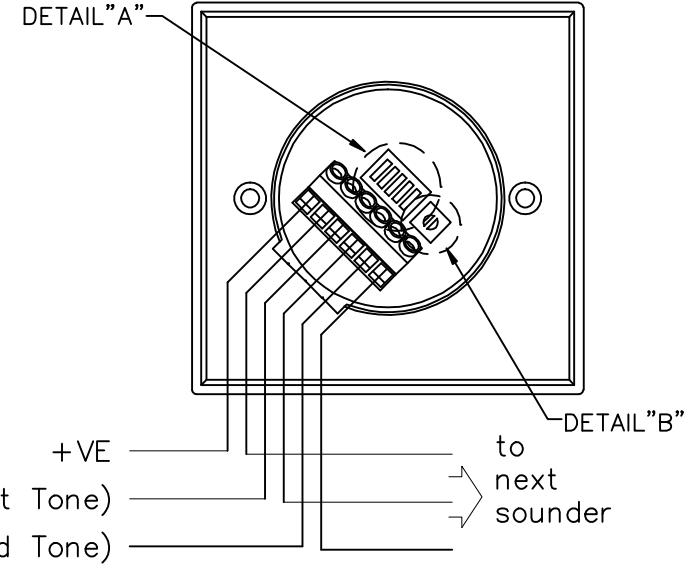
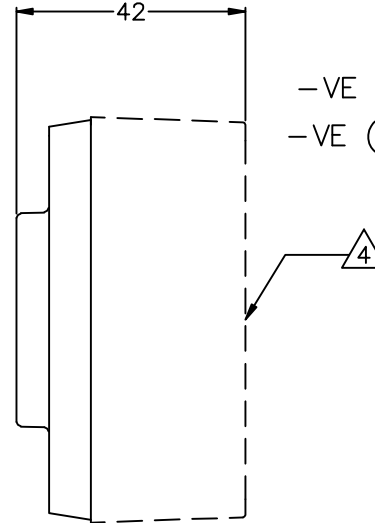
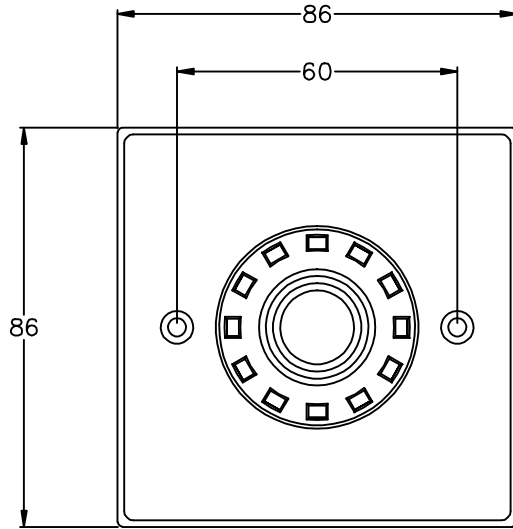

NOTES:

- ALL DIMENSIONS ARE IN MILLIMETERS.
- SPECIFICATION SUBJECT TO CHANGE OR WITHDRAWAL WITHOUT NOTICE.
- THIS PART IS RoHS 2002/95/EC COMPLIANT.
- IP54 WITH BACK BOX.

FILE NAME
AW-10CSR.DWG

UNLESS OTHERWISE SPECIFIED:
DIMENSIONS ARE IN MILLIMETERS, TOLERANCES ARE ±0.5 AND ANGLES ARE ±3°.

APPROVALS	DATE
DRAWN <i>J.D.</i>	9/06
CHECKED <i>R.W.</i>	9/06
APPROVED <i>B.R.</i>	9/06

DO NOT SCALE DRAWING



projects®
unlimited

Dayton, Ohio











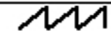
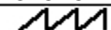
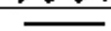
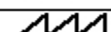
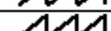
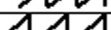
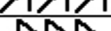
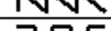
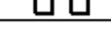
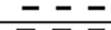

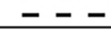
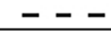

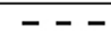
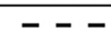
SIREN

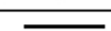
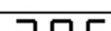
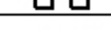
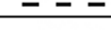
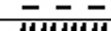
SIZE
A

DRAWING NO.
AW-10CSR

SCALE: N.T.S.

SHEET 1 OF 1

Primary tone	Secondary tone	Switch setting	Tone description				Main Application	AW-10				
								12 VDC	24Vdc on axis @1M	24 VDC	24Vdc on axis @1M	EN54-3 28Vdc see notes
			mA	dB(A)	mA	dB(A)		dB(A)				
1	14	11111	Alternating	800 & 970	2Hz (250ms-250ms)		BS Fire tone	10	91	18	95	*
2	14	11110	Sweep	800 to 970	7Hz (7/s)		BS Fire tone	10	94	18	97	*
3	14	11101	Sweep	800 to 970	1Hz (1/s)		BS Fire tone	10	94	18	97	94
4	14	11100	Continuous	2850	Steady			16	102	32	105	*
5	4	11011	Sweep	2400 to 2850	7Hz			18	101	30	106	*
6	4	11010	Sweep	2400 to 2850	1Hz			17	101	30	106	*
7	14	11001	Slow whoop	300 to 1200	3s sweep, 0.5 s silence, then repeat		Dutch Fire tone	12	92	20	96	94
8	14	11000	Sweep (DIN)	1200 to 500	1Hz		Din tone	9	91	16	95	93
9	4	10111	Alternating	2400 & 2850	2Hz (250ms-250ms)			19	100	30	105	*
10	14	10110	Intermittent	970	0.5Hz (1s On/1s Off)			9	89	12	93	*
11	14	10101	Alternating	800 & 970	1Hz (500ms-500ms)		BS Fire tone	10	90	18	95	*
12	4	10100	Intermittent	2850	0.5Hz (1s On/1s Off)			14	101	24	105	*
13	14	10011	Intermittent	970	0.8Hz (250ms On/1s Off)			5	85	8	90	*
14	14	10010	Continuous	970	Steady		BS Fire tone	11	90	20	94	95
15	14	10001	Alternating	554 & 440	100ms-400ms		French fire tone	7	86	12	91	*
16	16	10000	Intermittent	660	3.3Hz (150ms On/150msOff)		Swedish fire tone	6	83	9	88	*
17	17	01111	Intermittent	660	0.28Hz(1.8s On/1.8s Off)		Swedish fire tone	7	85	12	90	*
18	18	01110	Intermittent	660	0.05Hz (13s Off / 6.5Hz On)		Swedish fire tone	8	86	14	91	*
19	19	01101	Continuous	660	Steady		Swedish fire tone	8	86	14	91	*
20	20	01100	Alternating	554 & 440	0.5Hz (1s On/1s Off)		Swedish fire tone	7	86	13	91	*
21	21	01011	Intermittent	660	1Hz (500ms-500ms)		Swedish fire tone	6	84	10	89	*
22	14	01010	Intermittent	2850	4Hz (150ms On/100ms Off)		Pelican crossing	13	100	22	105	*
23	14	01001	Sweep	800 to 970	50Hz		BS Fire tone	10	92	18	96	*
24	4	01000	Sweep	2400 to 2850	50Hz			14	100	25	106	*
25	25	00111	Intermittent	970	3 x 500ms pulses followed by 1.5s silence then repeat		ISO 8201	9	88	14	92	*
26	26	00110	Intermittent	2850	3 x 500ms pulses followed by 1.5s silence then repeat		ISO 8201	12	100	20	104	*
27	27	00101	Continuous	4000	Steady			18	97	35	101	*
28	10	00100	Alternating	800 & 970	2Hz (250ms-250ms)		BS Fire tone	10	91	17	95	*
29	33	00011	Alternating	990 & 650	2Hz (250ms-250ms) (Symphoni tones)		BS Fire tone	8	90	17	97	94
30	35	00010	Alternating	510 & 610	2Hz (250ms-250ms) (Squashni Micro tones)		BS Fire tone	6	91	12	98	94
31	31	00001	Sweep	300 to 1200	1Hz			6	89	13	96	*
32	32	00000	Continuous	4000	Steady			18	97	12	99	*