

Ionization Smoke Detector with Interconnect

Features and Benefits

- Low average standby current for long battery life
- Interconnect up to 125 detectors
- Piezoelectric horn driver
- Guard outputs for detector input
- Pulse testing for low battery
- Power-on reset (POR)
- Internal reverse battery protection

Package: 16-pin DIP (suffix A)



Not to scale

Description

The A5350 is a low-current, CMOS circuit providing all of the required features for an ionization-type smoke detector. A networking capability allows as many as 125 units to be interconnected so that if any unit senses smoke all units will sound their alarm. In addition, special features are incorporated to facilitate alignment and test of the finished smoke detector.

The internal oscillator and timing circuitry keep standby power to a minimum by powering down the device for 1.66 seconds and sensing for smoke for only 10 ms. Every 24 on-off cycles, a check is made for a low battery condition. By substituting other types of sensors or a switch for the ionization detector, this very-low-power device can be used in numerous other battery-operated safety/security applications.

The A5350 is supplied in a low-cost 16-pin dual in-line plastic package (DIP). It is rated for continuous operation over the temperature range of 0°C to 50°C. The Pb (lead) free version (suffix -T) has 100% matte tin leadframe plating.

Typical Application

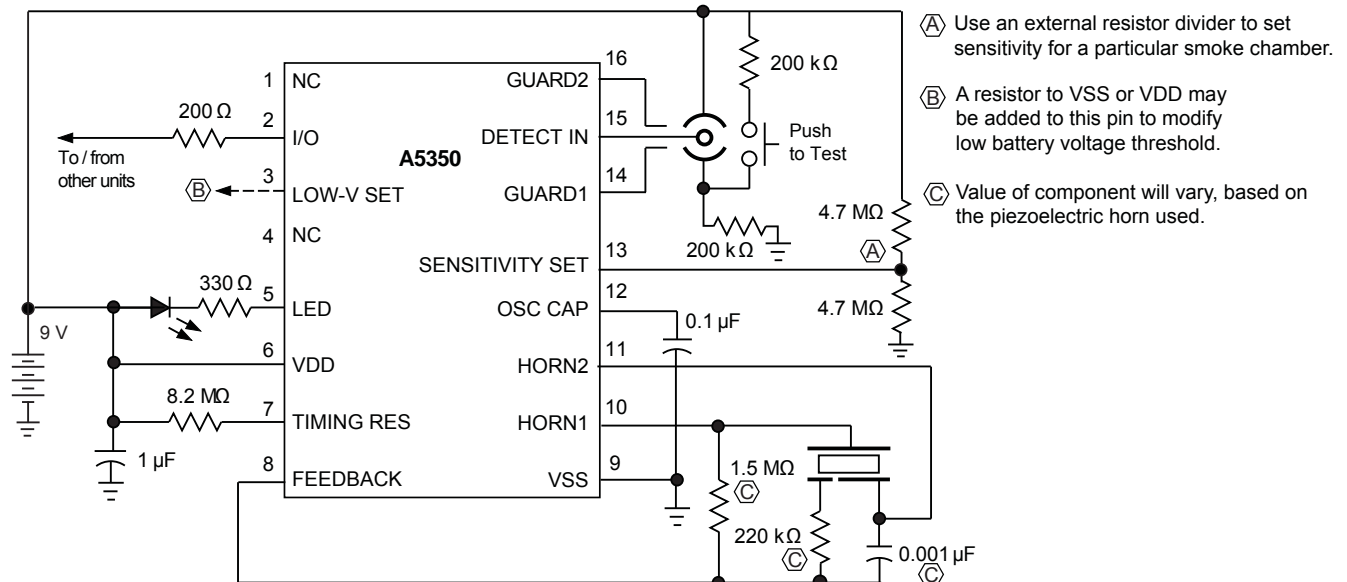

Selection Guide

Part Number	Pb-Free	Packing
A5350CA-T	Yes	25 pieces per tube
A5350CA	–	

Absolute Maximum Ratings*

Characteristic	Symbol	Notes	Rating	Units
Supply Voltage Range	V_{DD}	Referenced to V_{SS}	–0.5 to 15	V
Input Voltage Range	V_{IN}	Referenced to V_{SS}	–0.3 to $V_{DD} + 0.3$	V
Reverse Battery Condition Duration	t_{RBAT}	10.5 V	20	s
Input Current	I_{IN}		10	mA
Operating Ambient Temperature	T_A		0 to 50	°C
Junction Temperature	$T_{J(max)}$		150	°C
Storage Temperature Range	T_{stg}		–55 to 125	°C

* CAUTION: CMOS devices have input static protection but are susceptible to damage when exposed to extremely high static electrical charges.

THERMAL CHARACTERISTICS

Characteristic	Symbol	Test Conditions*	Value	Units
Package Thermal Resistance	$R_{\theta JA}$	4-layer PCB based on JEDEC standard	38	°C/W

*Additional thermal information available on Allegro website.

Pin-out Diagram

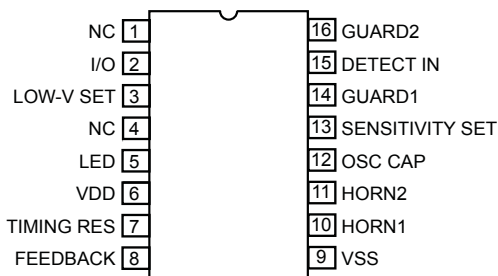

Terminal List Table

Number	Name	Function
1	NC	No connection
2	I/O	Input/output to interconnected detectors
3	LOW-V SET	Optionally used with a resistor to adjust low-battery threshold
4	NC	No connection
5	LED	Output to drive visible LED
6	VDD	Positive supply voltage
7	TIMING RES	Terminal for timing resistor, sets internal bias (affects timing)
8	FEEDBACK	Input for driving piezoelectric horn
9	VSS	Negative supply voltage
10	HORN1	Output for driving piezoelectric horn
11	HORN2	Complementary output for driving piezoelectric horn
12	OSC CAP	Terminal for charging/discharging an external capacitor to run the oscillator
13	SENSITIVITY SET	Used with a resistor divider to externally set sensitivity for a specific chamber
14	GUARD1	Active guard 1 for detector input
15	DETECT IN	Input from detector chamber
16	GUARD2	Active guard 2 for detector input

Functional Block Diagram

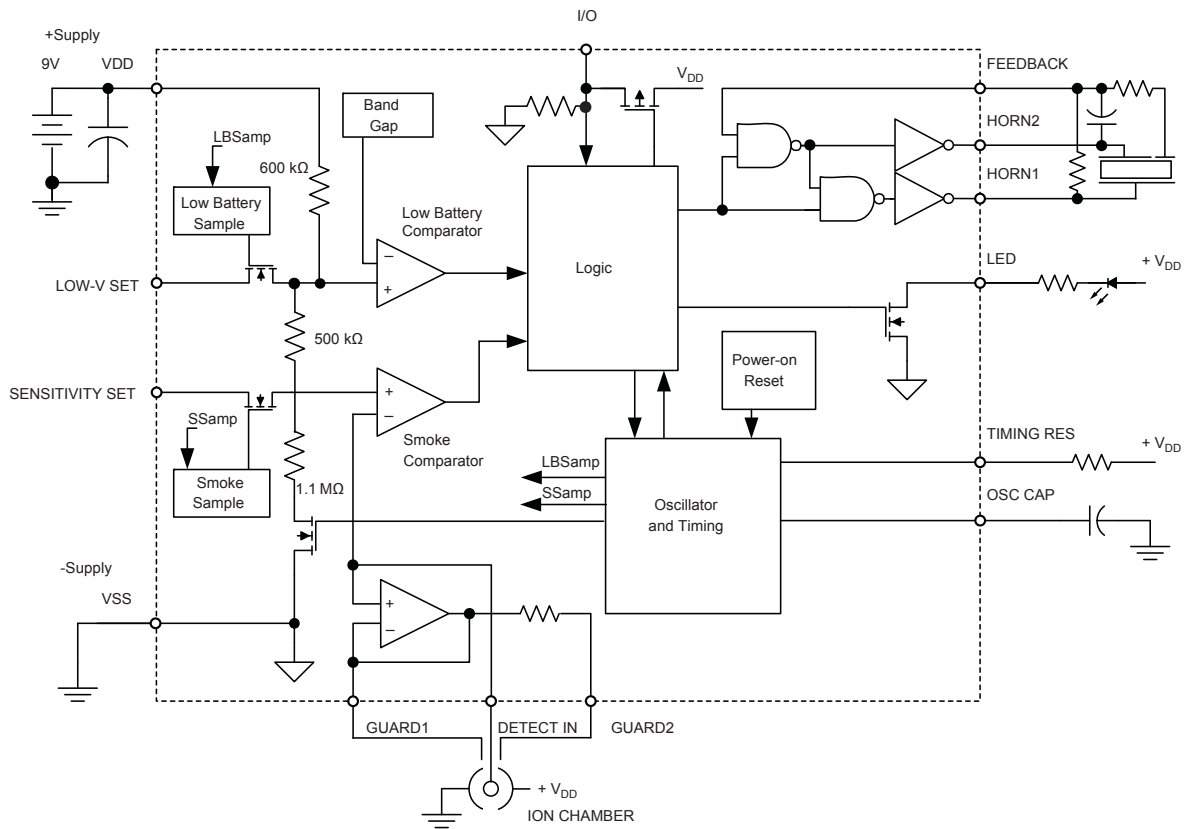

ELECTRICAL CHARACTERISTICS^{1,2} at $T_A = 25^\circ\text{C}$, $V_{DD} = 9.0\text{ V}$, $V_{SS} = 0\text{ V}$, $C_{OSSCAP} = 0.1\ \mu\text{F}$, $R_{TIMINGRES} = 8.2\ \text{M}\Omega$ (unless otherwise noted)

Characteristic	Symbol	Test Conditions	Test Pin	Min.	Typ.	Max.	Units
Supply Voltage Range	V_{DD}	Operating	6	6.0	9.0	12	V
Supply Current	I_{DD}	$V_{DD} = 9.0\text{ V}$, no alarm, no loads	6	—	5.0	9.0	μA
		$V_{DD} = 12\text{ V}$, no alarm, no loads	6	—	—	12	μA
Detector Input Current	$I_{DETECTIN}$	0% to 40% RH, $V_{IN} = 0$ to 9.0 V	15	—	—	± 1.0	pA
Input Offset Voltage	$V_{OS(GUARD1)}$	Active GUARD1	14, 15	—	—	± 100	mV
	$V_{OS(GUARD2)}$	Active GUARD2	16, 15	—	—	± 100	mV
	V_{OS}	Detect comparator	15, 13	—	—	± 50	mV
Common Mode Range	$V_{CM(\text{guard})}$	Guard amplifier	14, 15	2.0	—	$V_{DD} - 0.5$	V
	V_{CM}	Smoke comparator	13, 15	0.5	—	$V_{DD} - 2.0$	V
Active Guard Impedance	Z_{AG1}	GUARD1 to VSS	14	—	10	—	$\text{k}\Omega$
	Z_{AG2}	GUARD2 to VSS	16	—	500	—	$\text{k}\Omega$
Oscillator Period	t_{osc}	No alarm	12	1.34	1.67	2.00	s
	$t_{osc(\text{alarm})}$	Local or remote alarm	12	32	40	48	ms
Oscillator Pulse Width	$t_{w(\text{osc})}$		12	8.0	10	12	ms
Low-Battery Threshold	$V_{DD(\text{th})}$	$T_A = 0^\circ\text{C}$ to 50°C , LOW-V SET open circuit	6	7.2	—	7.8	V
Horn Output Voltage	V_{OL}	$I_{OUT} = 16\text{ mA}$, $V_{DD} = 9.0\text{ V}$	10, 11	—	0.1	0.5	V
		$I_{OUT} = 16\text{ mA}$, $V_{DD} = 7.2\text{ V}$	10, 11	—	—	0.9	V
	V_{OH}	$I_{OUT} = -16\text{ mA}$, $V_{DD} = 9.0\text{ V}$	10, 11	8.5	8.8	—	V
		$I_{OUT} = -16\text{ mA}$, $V_{DD} = 7.2\text{ V}$	10, 11	6.3	—	—	V
Horn Output On-Time	$t_{on(\text{horn})}$	Local or remote alarm	10, 11	120	160	208	ms
	$t_{w(\text{horn})}$	Low battery	10, 11	8.0	10	12	ms
Horn Output Off-Time	$t_{off(\text{horn})}$	Local or remote alarm	10, 11	60	80	104	ms
	t_{horn}	Low battery	10, 11	32	40	48	s
LED Output-On Current	I_{LED}	$V_{DD} = 7.2\text{ V}$, $V_{LED} = 1.0\text{ V}$	5	10	—	—	mA
LED Output On-Time	$t_{w(LED)}$		5	8.0	10	12	ms
LED Output Off-Time	t_{LED1}	No alarm, in standby	5	32	40	48	s
	t_{LED3}	Local alarm or test alarm	5	0.76	0.97	1.14	s
	t_{LED4}	Remote alarm, no local smoke	5	—	No LED pulses	—	s

Continued on the next page...

ELECTRICAL CHARACTERISTICS^{1,2} (continued) at $T_A = 25^\circ\text{C}$, $V_{DD} = 9.0\text{ V}$, $V_{SS} = 0\text{ V}$, $C_{OSCCAP} = 0.1\ \mu\text{F}$, $R_{TIMINGRES} = 8.2\ \text{M}\Omega$ (unless otherwise noted)

Characteristic	Symbol	Test Conditions	Test Pin	Min.	Typ.	Max.	Units
I/O Current	I_{IOL}	No alarm, $V_{I/O} = V_{DD} - 2.0\text{ V}$	2	25	—	60	μA
	I_{IOH}	Local alarm, $V_{I/O} = V_{DD} - 2.0\text{ V}$	2	-7.5	—	—	mA
I/O Alarm Voltage	$V_{IH(I/O)}$	External "alarm" in	2	3.0	—	—	V
I/O Delay	$t_{r(I/O)}$	Local or test alarm to I/O active	2	—	3.0	—	s

¹Negative current is defined as coming out of the specified device pin (sourcing).

²Alarm (smoke) condition is defined as $V_{DETECTIN} > V_{SENSITIVITYSET}$; no alarm (no smoke) condition is defined as $V_{DETECTIN} < V_{SENSITIVITYSET}$.

Circuit Description

The A5350 is a low-current, CMOS circuit providing all of the required features for an ionization-type smoke detector.

Oscillator

An internal oscillator operates with a period of 1.67 seconds during no-smoke conditions. Every 1.67 seconds, internal power is applied to the entire circuit for 10 ms and a check is made for smoke. Every 24 clock cycles (approximately 40 seconds), the LED pin is pulsed and a check is made for low battery by comparing V_{DD} to an internal reference. Because very-low currents are used in the device, the oscillator capacitor at the OSC CAP pin should be a low-leakage type (PTFE, polystyrene, or polypropylene).

Detector Circuitry

When the voltage on the DETECT IN pin is greater than the voltage on the SENSITIVITY SET pin, the A5350 evaluates this as a *smoke condition*.

An active guard is provided on GUARD1 and GUARD2, the two pins adjacent to the detector input, the DETECT IN pin. V_{GUARD1} and V_{GUARD2} will be within 100 mV of $V_{DETECTIN}$. This will

keep surface leakage currents to a minimum and provide a method of measuring the input voltage without loading the ionization chamber. The active guard amplifier is not power strobed and thus provides constant protection from surface leakage currents. The detector input has internal diode protection against electrostatic damage.

Alarm Circuitry

If smoke is detected, the oscillator period changes to 40 ms and the horn is enabled. The horn output is typically 160 ms on, 80 ms off. During the off-time, smoke is checked and further alarm output will be inhibited if smoke is not sensed. During a smoke condition, the low-battery alarm is inhibited and the LED is pulsed approximately once every second.

Sensitivity Adjust

The detector sensitivity must be externally set to the individual characteristics of the ionization chamber by connecting the SENSITIVITY SET pin to a resistor divider connected between the VDD and VSS pins.

Low Battery

The low battery condition threshold is set internally by a voltage divider connected between VDD and VSS. The threshold can be externally adjusted by connecting a resistor between the LOW-V SET pin and either the VDD or VSS pins.

To increase the threshold, a resistor can be connected between LOW-V SET and VSS. Given an initial threshold, $V_{(th)init}$ (nominally 7.5 V), and a target threshold, $V_{(th)set}$, the resistor should have the value:

$$R_{LOWVSET} = 600E3 \times K / (1 - 0.375 \times K) ,$$

where

$$K = 1 / (V_{(th)set} / [0.727 \times V_{(th)init}] - 1) .$$

To decrease the threshold, a resistor can be connected between LOW-V SET and VDD. Given an initial threshold, $V_{(th)init}$ (nominally 7.5 V), and a target threshold, $V_{(th)set}$, the resistor should have the value:

$$R_{LOWVSET} = 960E3 \times K / (0.6 - 1.6 \times K) ,$$

where

$$K = V_{(th)set} / (0.727 \times V_{(th)init}) - 1 .$$

The battery voltage level is checked approximately every 40 seconds during the (approximately) 10 mA, 10 ms LED pulse. If an

LED is not used, it should be replaced with an equivalent resistor (typically 500 to 1000 Ω) such that the battery loading remains about 10 mA.

I/O

A connection to the I/O pin allows multiple smoke detectors to be interconnected. If any single unit detects smoke, its I/O pin is driven high (after a nominal 3 s delay), and all connected units will sound their associated horns. The LED is suppressed when an alarm is signaled from an interconnected unit, and any local alarm condition causes the I/O pin to be ignored as an input. This pin has an on-chip pulldown device and must be left unconnected if not used.

Testing

On power-up, all internal counters are reset. Internal test circuitry allows low battery check by holding the FEEDBACK and OSC CAP pins low during power-up, then reducing V_{DD} and monitoring the HORN1 pin. HORN1 will be driven high when V_{DD} falls below the low-battery threshold. All functional tests can be accelerated by driving the OSC CAP pin with a 2 kHz square wave. The 10 ms strobe period must be maintained for proper operation of the comparator circuitry.

Timing Diagrams
(Not to scale)

▮ Test event

Standby Mode

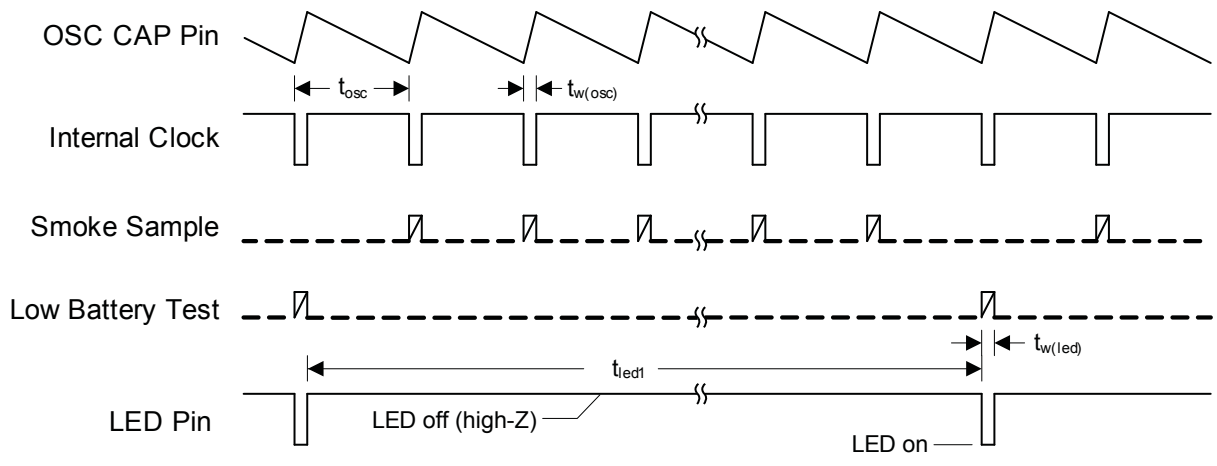

Low Battery Condition

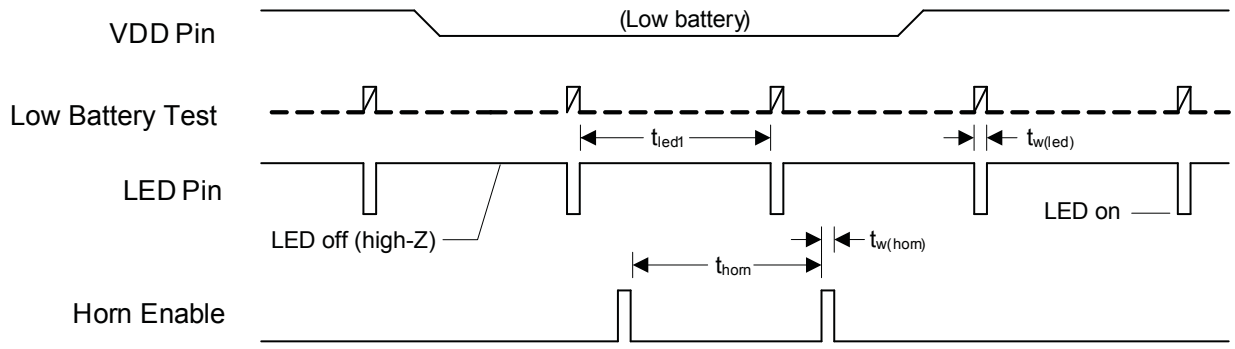

Local Smoke Detection/Test Alarm Condition

∇ Test event

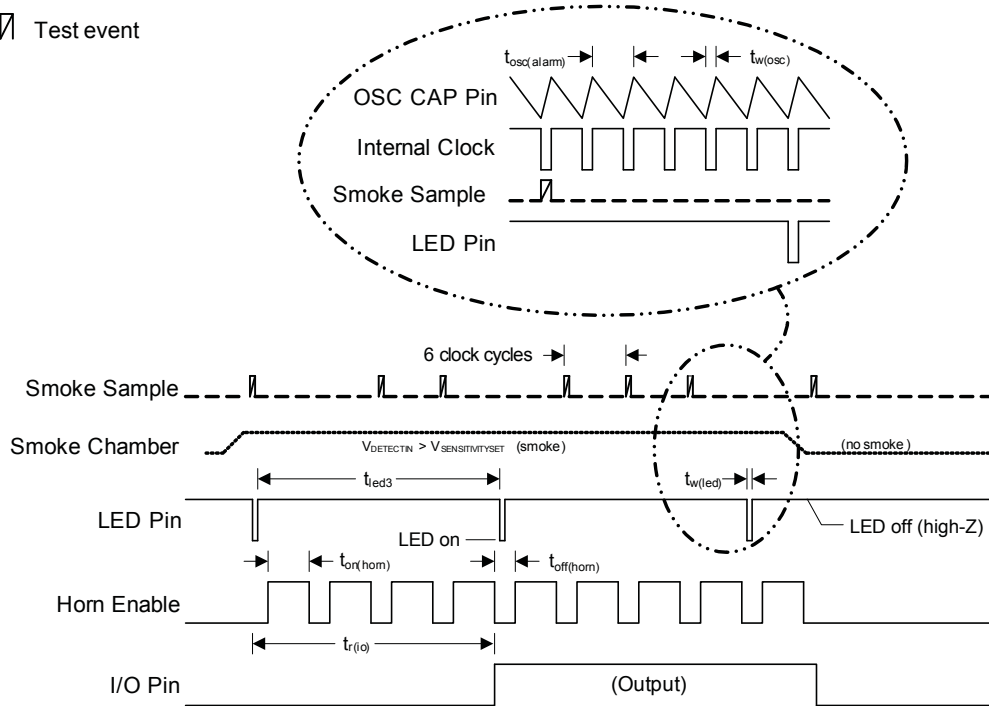

Remote Alarm Condition

