

PRODUCT NUMBER
SEE TABLE

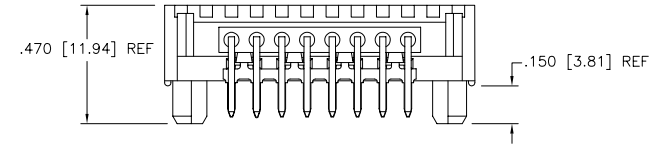
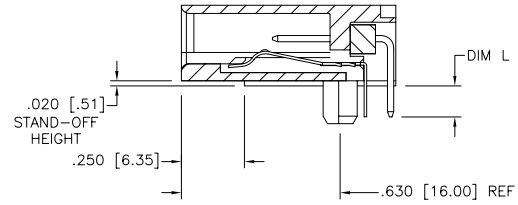
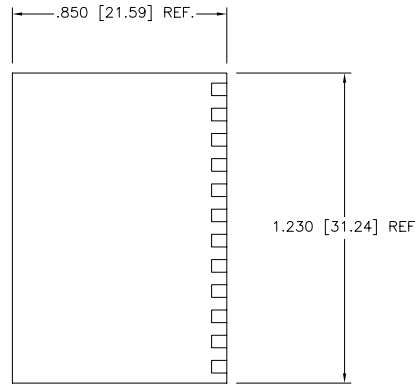

mat'l. code		surface ISO 1302 ✓		tolerance ISO 406 ISO 1101		projection ⊕		product family LATCH-N-LOK	
A		JRL 7/17/90		tolerances unless otherwise specified		INCH/MM		title 1X8 LNL RIGHT ANGLE HEADER ASSEMBLY	
B V01017		TFG 5/12/00		angles		linear .XX±.01/.3		dwg no 69913	
C V10985		TFG 2/13/01		0°±2'		.xxx±.005/.13		sheet 1 of 2 size A3	
D M04-0230		MHT 12/8/04		dr		.xxxx±.0020/.051		scale 1:1	
E M05-0052		ERE 3/19/05		engr		J. LINN 7/17/90		FCJ	
F M06-0285		AGS 7/28/06		chr		D. HORCHLER 7/17/90		type Product Customer Drawing	
G M06-0365		AGS 9/20/06		appd		D. HORCHLER 7/17/90			
sheet	revision	G	G						
index	sheet	1	2						

FCJ
FCIconnect.com

Copyright FCI

69913-XXXLF

LEAD FREE OPTION (6) (8)

COLOR (4)	
1	70343 LT GRAY OBS
2	80166 OFF WHITE OBS
3	70634 DK GRAY OBS
4	701 BLACK OBS
5	70541 SLATE GRAY OBS
7	70455 SILVER GRAY OBS
8	80189 PEARL WHITE OBS
9	70419 PEBBLE GRAY OBS

PLATING (9)	
0	30u" GXT
3	30u" AU OVER 50u" NI
5	50u" AU OVER 50u" NI

PIN LENGTH	
	DIM L
0	1.50/3.18
1	.110/2.79

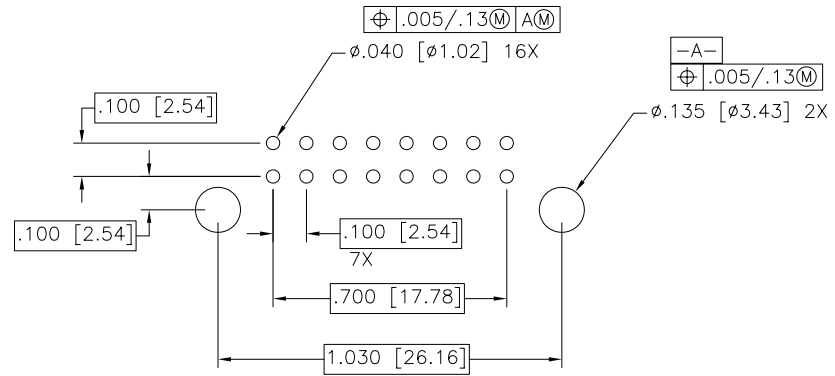

RECOMMENDED PCB LAYOUT

NOTES:

- HEADER SHROUD MAT'L: POLYCARBONATE.
- GROUND CONTACT
MAT'L: COPPER ALLOY
PLATING: 100-160u"/2.54-4.06u" TIN.
- SIGNAL CONTACT
MAT'L: COPPER ALLOY
PLATING: SEE TABLE
- (4) NUMBERS SHOWN ARE FOR G.E. LEXAN AND ARE FOR REFERENCE ONLY.
- (5) THIS ASSEMBLY U.L. APPROVED PER FILE E66906 VOL. 1, SEC. 84 AND CSA APPROVED PER MASTER FILE LR46923
- (6) ADD LF SUFFIX AT THE END OF PART NUMBER FOR LEAD FREE OPTION.
- THE HOUSING WILL WITHSTAND EXPOSURE TO 260°C PEAK TEMPERATURE FOR 15 SECONDS IN A WAVE SOLDER APPLICATION WITH A 1.5mm MINIMUM THICK CIRCUIT BOARD. SEE APPLICATION NOTES/PROCEDURES IF THEY ARE AVAILABLE.
- (8) THIS PRODUCT MEETS EUROPEAN UNION DIRECTIVES AND OTHER COUNTRY REGULATION AS DESCRIBED IN GS-22-008.
- (9) PLATING OPTIONS:
MAY BE EITHER GOLD OR GXT PLATED AT MANUFACTURER'S OPTION.



FCIconnect.com

Copyright FCI

mat'l. code		surface ISO 1302 ✓		tolerance ISO 406 ISO 1101		projection INCH/MM		product family LATCH-N-LOK	
ltr	ecn	no	dr	date		tolerances unless otherwise specified		title	
G						angles	linear	1X8 LNL RIGHT ANGLE HEADER ASSEMBLY	
						0°±2'	.XX±.01/.3 .XXX±.005/.13 .XXX±.0020/.051	scale 1:1	
						dr	J. LINN	7/17/90	
						enr	D. HORCHLER	7/17/90	
						chr	D. HORCHLER	7/17/90	
						app	D. HORCHLER	7/17/90	
sheet index		revision sheet						sheet 2 of 2 size A3	
								type Product Customer Drawing	

form: A3