

NEW PRODUCT

For Board to wire

XSR CONNECTOR

0.6mm Pitch

This is the world's smallest 0.6mm pitch ID connector for discrete wires.

This Wire to Board miniaturised connector has a mounting height of 1.45mm and depth of 3.0mm.

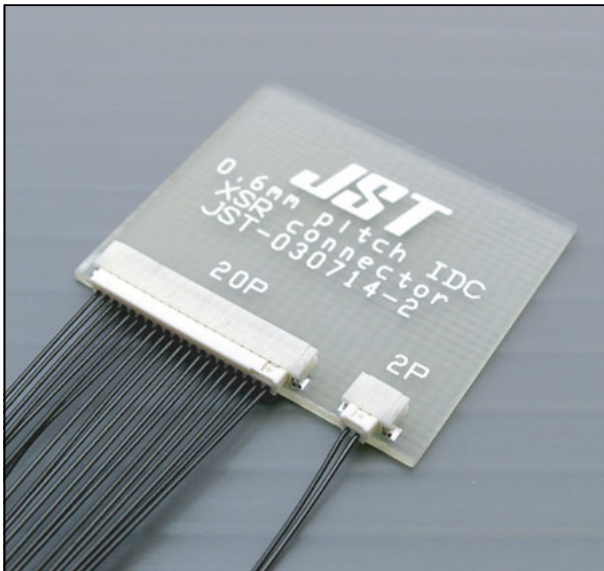

■ Features

● Twin U-slot ID part

The ID connection part consists of a proven twin U-slot structure which guarantees highly reliable contact.

● New strain relief structure

This new design approach to strain relief provides reliable wire retention despite being a narrow pitch one-piece socket connector.

● Suitable for fine wires

The adoption of the AWG#36 wire with a 0.29mm O.D. provides toughness and flexibility, which provides freedom in wiring and space saving features.

● Applicable to automatic ID machines

A new fully automatic ID machine, BCD-M5S, provides stable mass production of the harness.

**The world's first
0.6mm ID connector**

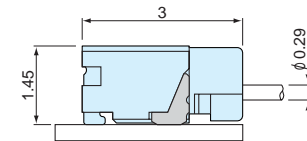
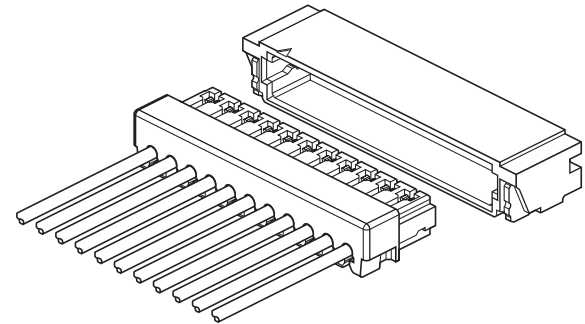

■ Specifications

- Current rating : 0.2A AC,DC
- Voltage rating : 30 V AC,DC
- Temperature : -25 °C to +85 °C (including temperature range rise in applying electrical current)
- Applicable wires : AWG #36 (7 strand tinned copper alloy wire)
Insulation O.D: 0.29mm dia
- No. of Circuits : 2,4,6,10,16,20&22 circuits (2 to 22 planned)
- Direction of entry : Side entry

J.S.T. MFG. CO., LTD.

<http://www.jst-mfg.com>