

Wound Beads

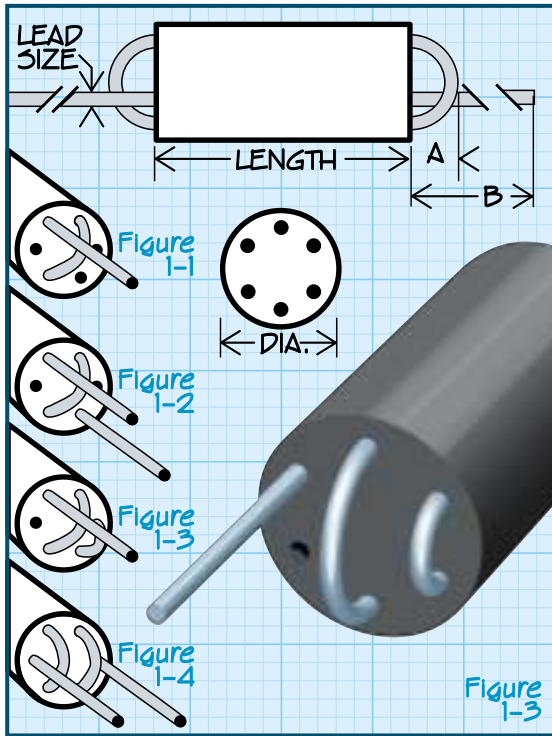

DASH NUMBER*	FIGURE	# OF TURNS	MINIMUM IMPEDANCE					
			@ 10 MHz	@ 50 MHz	@ 100 MHz	@ 150 MHz	@ 200 MHz	@ 220 MHz
-1	1-3	2½	—	—	750	700	—	400
-2	1-3	2½	325	—	575	525	—	—
-3	1-1	1½	—	325	425	—	400	—
-4	1-1	1½	170	320	375	—	—	—
-5	1-2	2	—	525	600	—	600	—
-6	1-2	2	240	520	480	—	—	—
-7	1-4	3	—	950	900	—	600	—
-8	1-4	3	400	800	550	—	—	—

*Complete part # must include series # PLUS the dash #
For further surface finish information, refer to TECHNICAL section of this catalog.

Physical Parameters

	Inches	Millimeters
Length	0.374 to 0.414	9.50 to 10.51
Diameter	0.216 to 0.256	5.48 to 6.35
Lead Size		
AWG #24 TCW	0.0185 to 0.0215	0.47 to 0.55
A	0.12 Max.	3.05 Max.
B	1.10 Min.	28.0 Min.

Impedances measured on HP 4191A Impedance Analyzer.

High resistivity ferrite material eliminates the need to insulate windings.

Lead Wire Plated copper

Packaging Bulk only

For more detailed graphs, contact factory

