

VC-AR2/3M

Order No.: 1852985

<http://eshop.phoenixcontact.de/phoenix/treeViewClick.do?UID=1852985>

Panel mounting frame, without PE, for contact insert modules, type 2,
number of insert modules 3

Commercial data

EAN	4017918134341
Pack	5 Pcs.
Customs tariff	85389099
Weight/Piece	0.01229 KG
Catalog page information	Page 294 (PC-2007)

Product notes

WEEE/RoHS-compliant since:
12/15/2005



<http://www.download.phoenixcontact.com>
Please note that the data given here has been taken from the online catalog. For comprehensive information and data, please refer to the user documentation. The General Terms and Conditions of Use apply to Internet downloads.

Technical data**General data**

Note	2 x 1852862 VC-AF for each connector
Ambient temperature (operation)	-40 °C ... 125 °C
Design	VC2

Material data

Inflammability class acc. to UL 94	V0
------------------------------------	----

Certificates / Approvals

Approval logo



requested approbations

Certification	CUL, GOST, UL
---------------	---------------

Accessories

Item	Designation	Description
1852862	VC-AF	Panel-mounting flange for screw locking, for wall thicknesses of 1-5 mm

Drawings

Dimensioned drawing

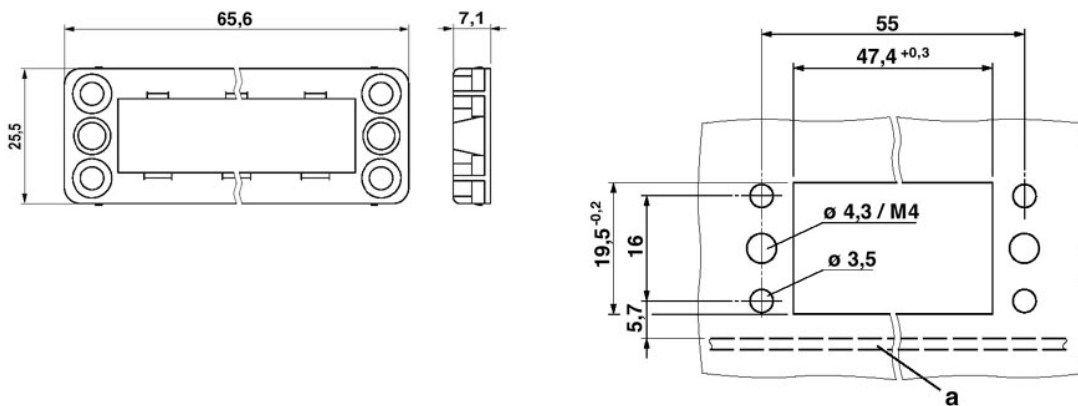

Address

PHOENIX CONTACT GmbH & Co. KG
Flachsmarktstr. 8
32825 Blomberg, Germany
Phone +49 5235 3 00
Fax +49 5235 3 41200
<http://www.phoenixcontact.de>



© 2008 Phoenix Contact
Technical modifications reserved;