

2mm × 2mm Pin Strip Header

Straight & Right Angle, Solder Tail

1512 Series



- Industry standard compatible
- High temperature dielectric
- IR, vapor & wave solder compatible
- Unique lengths available
- Maximizes use of PC board space
- Mates with boardmount and wiremount products
- End stackable feature
- Side stackable feature

Date Modified: February 19, 1999

TS-0808-02
Sheet 1 of 3

36

Physical

Insulation

Material: Glass Filled Polyester (PCT)
Flammability: UL 94V-0
Color: Natural or Black

Contact

Material: Copper Alloy
Plating
Underplate: 100 μ " [2.54 μ m] Nickel — QQ-N-290, Class 2
Wiping Area: Gold — MIL-G-45204, Type II, Grade C
Solder Tails: 200 μ " [5.08 μ m] 90/10 Tin Lead, MIL-P-81728

Note: The location and thickness of the contact plating is determined by the part number. Refer to ordering information.

Electrical

Current Rating: 1.5 A
Insulation Resistance: $> 5 \times 10^9 \Omega$ at 250 Vdc
Withstanding Voltage: 500 Vdc at Sea Level

Environmental

Temperature Rating: -55°C to $+105^\circ\text{C}$

UL File No.: E68080

3M Interconnect Solutions Division

6801 River Place Blvd.
Austin, TX 78726-9000

For technical, sales or ordering information call
800-225-5373

2mm × 2mm Pin Strip Header

Straight & Right Angle, Solder Tail

1512 Series

Straight

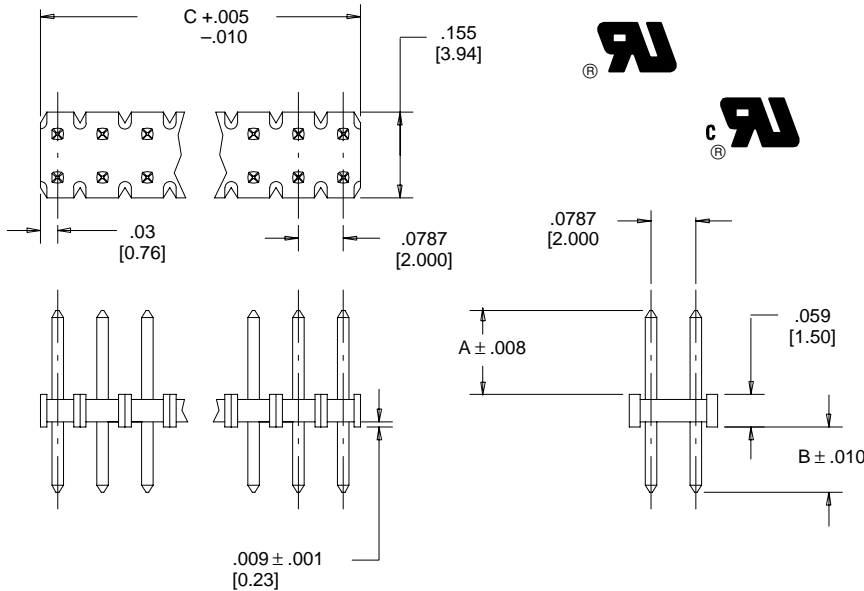

Contact Quantity	Dimension C
04	.139 [3.5]
06	.217 [5.5]
08	.295 [7.5]
10	.374 [9.5]
12	.453 [11.5]
14	.531 [13.5]
16	.611 [15.5]
18	.689 [17.5]
20	.768 [19.5]
22	.847 [21.5]
24	.925 [23.5]
26	1.005 [25.5]
28	1.083 [27.5]
30	1.162 [29.5]
32	1.240 [31.5]
34	1.320 [33.5]
36	1.398 [35.5]
38	1.477 [37.5]
40	1.556 [39.5]
42	1.634 [41.5]
44	1.714 [43.5]
46	1.792 [45.5]
48	1.870 [47.5]
50	1.950 [49.5]
52	2.028 [51.5]
54	2.107 [53.5]
56	2.185 [55.5]
58	2.264 [57.5]
60	2.344 [59.5]

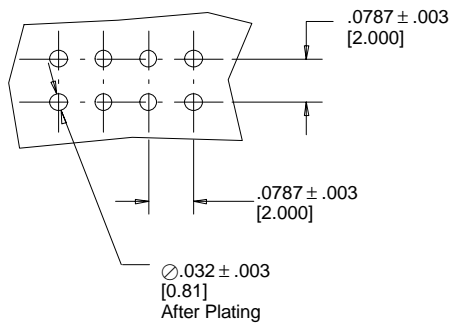

Recommended Mounting Hole Pattern

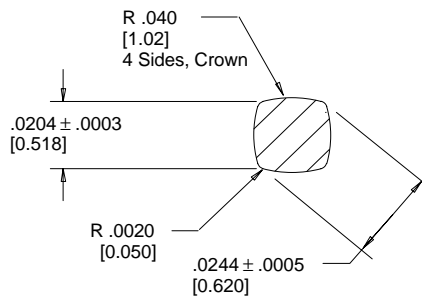

Pin Cross Section

Inch
[mm]

Tolerance Unless Noted			
	.0	.00	.000
Inch	± .1	± .01	± .005

[] Dimensions for Reference only

Ordering Information

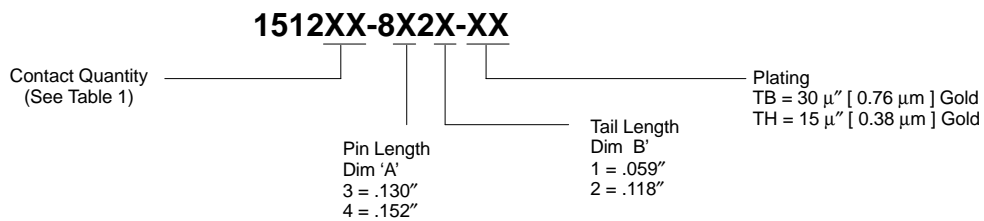

TS-0808-02
Sheet 2 of 3

3M Interconnect Solutions Division

6801 River Place Blvd.
Austin, TX 78726-9000

For technical, sales or ordering information call
800-225-5373

2mm × 2mm Pin Strip Header

Straight & Right Angle, Solder Tail

1512 Series

Right Angle

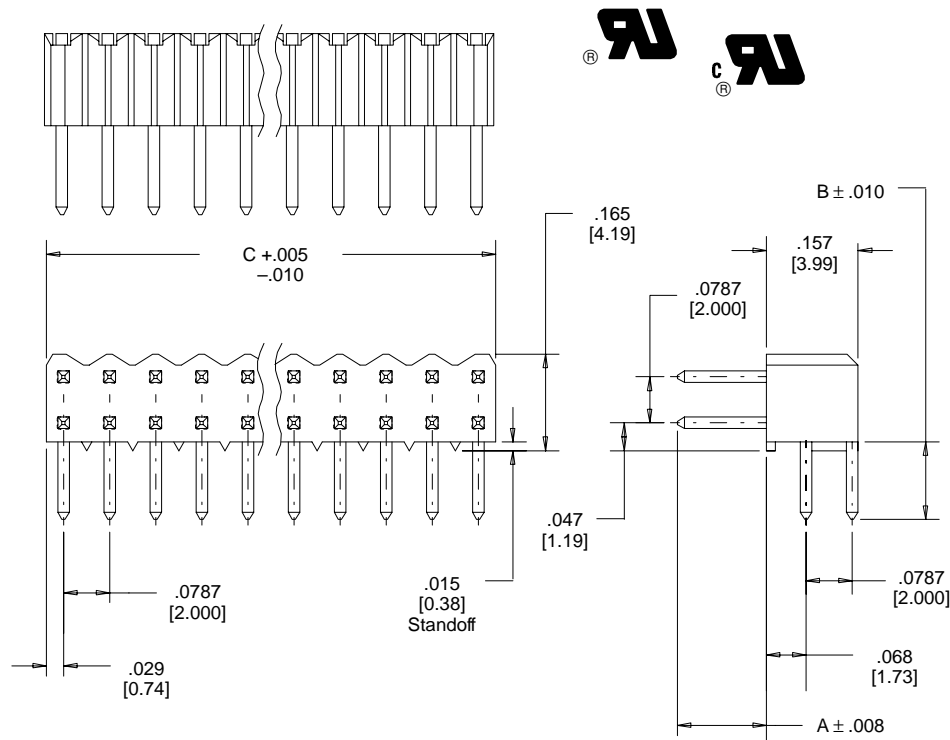

Contact Quantity	Dimension C
04	.139 [3.5]
06	.217 [5.5]
08	.295 [7.5]
10	.374 [9.5]
12	.453 [11.5]
14	.531 [13.5]
16	.611 [15.5]
18	.689 [17.5]
20	.768 [19.5]
22	.847 [21.5]
24	.925 [23.5]
26	1.005 [25.5]
28	1.083 [27.5]
30	1.162 [29.5]
32	1.240 [31.5]
34	1.320 [33.5]
36	1.398 [35.5]
38	1.477 [37.5]
40	1.556 [39.5]
42	1.634 [41.5]
44	1.714 [43.5]
46	1.792 [45.5]
48	1.870 [47.5]
50	1.950 [49.5]
52	2.028 [51.5]
54	2.107 [53.5]
56	2.185 [55.5]
58	2.264 [57.5]
60	2.344 [59.5]

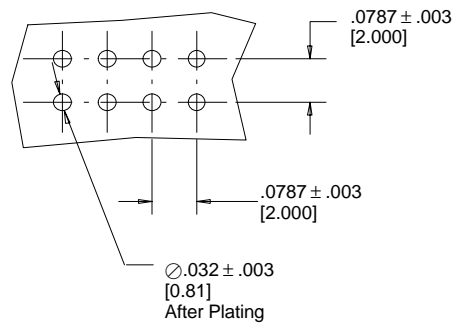

Recommended Mounting Hole Pattern

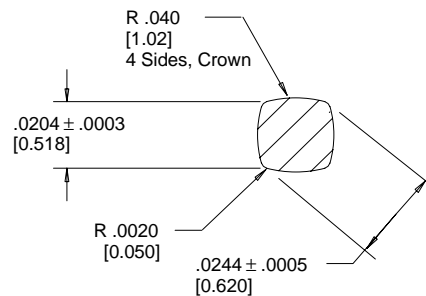

Pin Cross Section

Inch [mm]

Tolerance Unless Noted			
	.0	.00	.000
Inch	$\pm .1$	$\pm .01$	$\pm .005$

[] Dimensions for Reference only

Ordering Information

1512XX-7X2X-XX

Contact Quantity
(See Table 1)

Pin Length
Dim A
3 = .130"
4 = .152"

Tail Length
Dim B
1 = .059"
2 = .118"

Plating
TB = 30 μ m [0.76 μ m] Gold
TH = 15 μ m [0.38 μ m] Gold

TS-0808-02
Sheet 3 of 3

3M Interconnect Solutions Division

6801 River Place Blvd.
Austin, TX 78726-9000

For technical, sales or ordering information call
800-225-5373