

SMA 50 Ohm Straight Clamp Type Plug - Captivated Contact

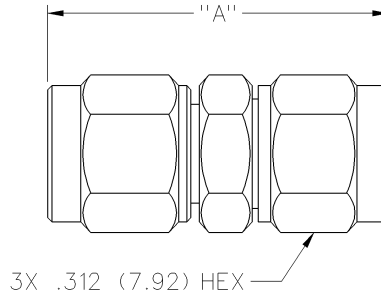

| CABLE TYPE | VSWR & FREQ. RANGE | GOLD PLATED | NICKEL PLATED | "A" |
|--------------------------------------|-------------------------------|--------------|---------------|--------------|
| RG-58/U, 141, 303, 55, 142, 223, 400 | 1.15 + .01 f (GHz) 0-12.4 GHz | 142-0207-011 | 142-0207-016 | .895 (22.73) |

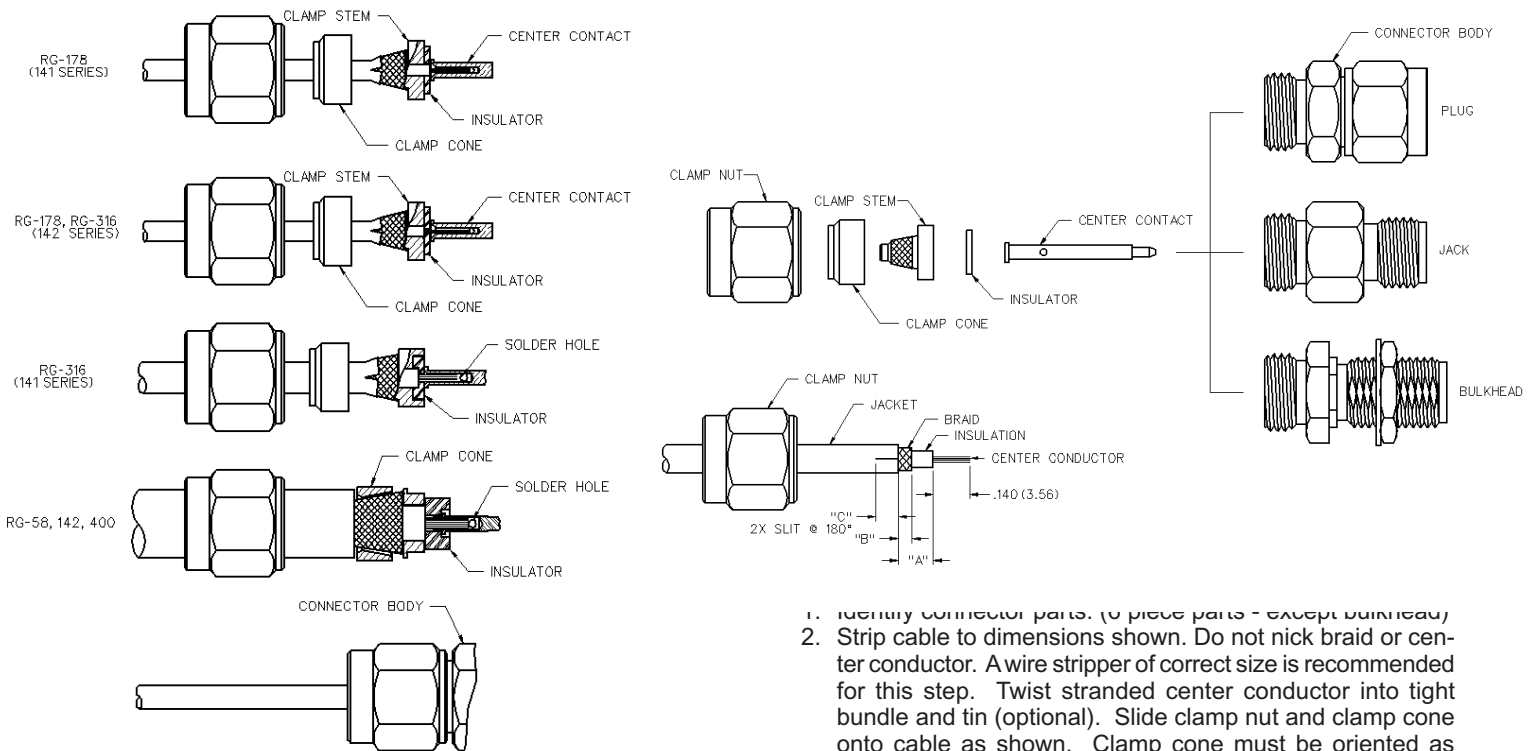

1. Identify connector parts. (6 piece parts - except bulkhead)
2. Strip cable to dimensions shown. Do not nick braid or center conductor. A wire stripper of correct size is recommended for this step. Twist stranded center conductor into tight bundle and tin (optional). Slide clamp nut and clamp cone onto cable as shown. Clamp cone must be oriented as shown for each size of cable. The RG-58/142 clamp cone slides over braid and against jacket.
3. Flare braid and slide cable into clamp stem. Place rear insulator and center contact over center conductor and position as shown for different cable sizes. Solder center conductor to contact through the solder hole. Solder **must not** be allowed to gather and run on outside of contact. Use a minimum amount of solder for a good joint. **.020 (0.51) diameter solder is recommended.**
4. Arrange braid uniformly around clamp stem. Slide center contact assembly into body. Slide clamp nut against clamp cone and braid and tighten to 10 in.-lb. torque.

| CABLE GROUP | PART NUMBER | "A" | "B" | "C" |
|-------------------|------------------|-------------|-------------|------|
| RG-58/u, 141, 303 | 142-0207-011/016 | .225 (5.72) | .145 (3.68) | NONE |

SMA - 50 Ohm Connectors

Specifications

ELECTRICAL RATINGS

Impedance: 50 ohms

Frequency Range:

| | |
|---|------------|
| Dummy loads | 0-2 GHz |
| Flexible cable connectors | 0-12.4 GHz |
| Uncabled receptacles, RA semi-rigid and adapters | 0-18.0 GHz |
| Straight semi-rigid cable connectors and field replaceable connectors | 0-26.5 GHz |

VSWR: (f = GHz)

| | Straight Cabled Connectors | Right Angle Cabled Connectors |
|--|----------------------------|-------------------------------|
| RG-178 cable | 1.20 + .025f | 1.20 + .03f |
| RG-316, LMR-100 cable | 1.15 + .02f | 1.15 + .03f |
| RG-58, LMR-195 cable | 1.15 + .01f | 1.15 + .02f |
| RG-142 cable | 1.15 + .01f | 1.15 + .02f |
| LMR-200, LMR-240 cable | 1.10 + .03f | 1.10 + .06f |
| .086 semi-rigid | 1.07 + .008f | 1.18 + .015f |
| .141 semi-rigid (w/contact) | 1.05 + .008f | 1.15 + .015f |
| .141 semi-rigid (w/o contact) | 1.035 + .005f | |
| Jack-bulkhead jack adapter and plug-plug adapter | 1.05 + .01f | |
| Jack-jack adapter and plug-jack adapter | 1.05 + .005f | |
| Uncabled receptacles, dummy loads | N/A | |
| Field replaceable (see page 59) | N/A | |

Working Voltage: (Vrms maximum)†

| Connectors for Cable Type | Sea Level | 70K Feet |
|--|-----------|----------|
| RG-178 | 170 | 45 |
| RG-316; LMR-100, 195, 200 | 250 | 65 |
| RG-58, RG-142, LMR-240, .086 semi-rigid, uncabled receptacles, .141 semi-rigid w/o contact ... | 335 | 85 |
| .141 semi-rigid with contact and adapters | 500 | 125 |
| Dummy loads | N/A | |

Dielectric Withstanding Voltage: (VRMS minimum at sea level)†

| | |
|---|------|
| Connectors for RG-178 | 500 |
| Connectors for RG-316; LMR-100, 195, 200 | 750 |
| Connectors for RG-58, RG-142, LMR-240, .086 semi-rigid, field replaceable, uncabled receptacles | 1000 |
| Connectors for .141 semi-rigid with contact and adapters | 1500 |
| Connectors for .141 semi-rigid w/o contact, dummy loads | N/A |

Corona Level: (Volts minimum at 70,000 feet)†

| | |
|---|-----|
| Connectors for RG-178 | 125 |
| Connectors for RG-316; LMR-100, 195, 200 | 190 |
| Connectors for RG-58, RG-142, LMR-240, .086 semi-rigid, uncabled receptacles, .141 semi-rigid w/o contact | 250 |
| Connectors for .141 semi-rigid with contact and adapters | 375 |
| Dummy loads | N/A |

Insertion Loss: (dB maximum)

| | | |
|--|------|------------------------------------|
| Straight flexible cable connectors and adapters | 0.06 | \sqrt{f} (GHz), tested at 6 GHz |
| Right angle flexible cable connectors | 0.15 | \sqrt{f} (GHz), tested at 6 GHz |
| Straight semi-rigid cable connectors with contact | 0.03 | \sqrt{f} (GHz), tested at 10 GHz |
| Right angle semi-rigid cable connectors | 0.05 | \sqrt{f} (GHz), tested at 10 GHz |
| Straight semi-rigid cable connectors w/o contact | 0.03 | \sqrt{f} (GHz), tested at 16 GHz |
| Straight low loss flexible cable connectors | 0.06 | \sqrt{f} (GHz), tested at 1 GHz |
| Right Angle low loss flexible cable connectors | 0.15 | \sqrt{f} (GHz), tested at 1 GHz |
| Uncabled receptacles, field replaceable, dummy loads | | N/A |

Insulation Resistance: 5000 megohms minimum

Contact Resistance: (milliohms maximum) **Initial** **After Environmental**

| | | |
|--|------|------|
| Center contact (straight cabled connectors and uncabled receptacles) | 3.0* | 4.0* |
| Center contact (right angle cabled connectors and adapters) | 4.0 | 6.0 |
| Field replaceable connectors | 6.0 | 8.0 |
| Outer contact (all connectors) | 2.0 | N/A |
| Braid to body (gold plated connectors) | 0.5 | N/A |
| Braid to body (nickel plated connectors) | 5.0 | N/A |

*N/A where the cable center conductor is used as a contact

RF Leakage: (dB minimum, tested at 2.5 GHz)

| | |
|---|--------|
| Flexible cable connectors, adapters and .141 semi-rigid connectors w/o contact | -60 dB |
| Field replaceable w/o EMI gasket | -70 dB |
| .086 semi-rigid connectors and .141 semi-rigid connectors with contact, and field replaceable with EMI Gasket | -90 dB |
| Two-way adapters | -90 dB |
| Uncabled receptacles, dummy loads | N/A |

RF High Potential Withstanding Voltage: (Vrms minimum, tested at 4 and 7 MHz)†

| | |
|---|------|
| Connectors for RG-178 | 335 |
| Connectors for RG-316; LMR-100, 195, 200 | 500 |
| Connectors for RG-58, RG-142, LMR-240, .086 semi-rigid, .141 semi-rigid cable w/o contact, uncabled receptacles | 670 |
| Connectors for .141 semi-rigid with contact and adapters | 1000 |

Power Rating (Dummy Load): 0.5 watt @ + 25°C, derated to 0.25 watt @ +125°C

MECHANICAL RATINGS

Engagement Design: MIL-C-39012, Series SMA

Engagement/Disengagement Force: 2 inch-pounds maximum

Mating Torque: 7 to 10 inch-pounds

Bulkhead Mounting Nut Torque: 15 inch-pounds

Coupling Proof Torque: 15 inch-pounds minimum

Coupling Nut Retention: 60 pounds minimum

Contact Retention:

6 lbs. minimum axial force (captivated contacts)

4 inch-ounce minimum torque (uncabled receptacles)

Cable Retention:

| | Axial Force*(lbs) | Torque (in-oz) |
|--------------------------------------|-------------------|----------------|
| Connectors for RG-178 | 10 | N/A |
| Connectors for RG-316, LMR-100 | 20 | N/A |
| Connectors for LMR-195, 200 | 30 | N/A |
| Connectors for RG-58, LMR-240 | 40 | N/A |
| Connectors for RG-142 | 45 | N/A |
| Connectors for .086 semi-rigid | 30 | 16 |
| Connectors for .141 semi-rigid | 60 | 55 |

*Or cable breaking strength whichever is less.

Durability: 500 cycles minimum

100 cycles minimum for .141 semi-rigid connectors w/o contact

ENVIRONMENTAL RATINGS (Meets or exceed the applicable paragraph of MIL-C-39012)

Temperature Range: - 65°C to + 165°C

Thermal Shock: MIL-STD-202, Method 107, Condition B

Corrosion: MIL-STD-202, Method 101, Condition B

Shock: MIL-STD-202, Method 213, Condition I

Vibration: MIL-STD-202, Method 204, Condition D

Moisture Resistance: MIL-STD-202, Method 106

†Avoid user injury due to misapplication. See safety advisory definitions inside front cover.

SMA - 50 Ohm Connectors

Specifications

MATERIAL SPECIFICATIONS

Bodies: Brass per QQ-B-626, gold plated* per MIL-G-45204 .00001" min. or nickel plated per QQ-N-290

Contacts: Male - brass per QQ-B-626, gold plated per MIL-G-45204 .00003" min.

Female - beryllium copper per QQ-C-530, gold plated per MIL-G-45204 .00003" min.

Nut Retention Spring: Beryllium copper per QQ-C-533. Unplated

Insulators: PTFE fluorocarbon per ASTM D 1710 and ASTM D 1457 or Tefzel per ASTM D 3159 or PFA 340 per ASTM

Expansion Caps: Brass per QQ-B-613, gold plated per MIL-G-45204 .00001" min. or nickel plated per QQ-N-290

Crimp Sleeves: Copper per WW-T-799 or brass per QQ-B-613, gold plated per MIL-G-45204 .00001" min. or nickel plated per QQ-N-290

Mounting Hardware: Brass per QQ-B-626 or QQ-B-613, gold plated per MIL-G-45204 .00001" min. or nickel plated per QQ-N-290

Seal Rings: Silicone rubber per ZZ-R-765

EMI Gaskets: Conductive silicone rubber per MIL-G-83528, Type M

* All gold plated parts include a .00005" min. nickel underplate barrier layer.

Mating Engagement for SMA Series per MIL-C-39012

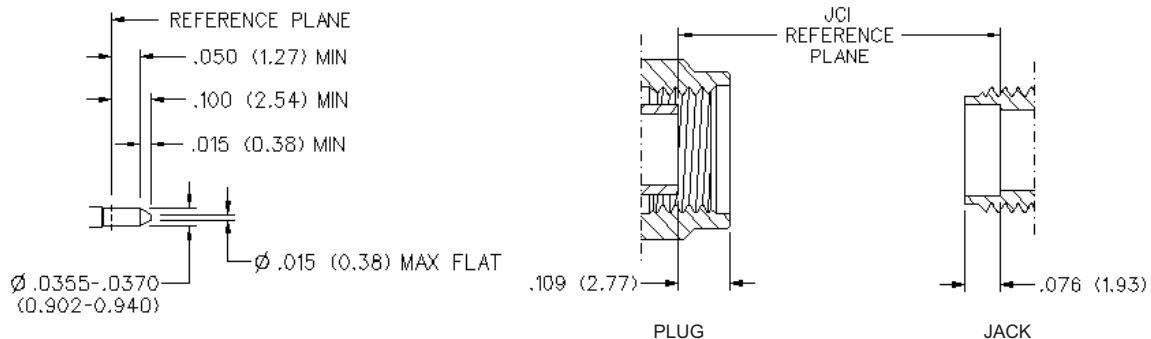
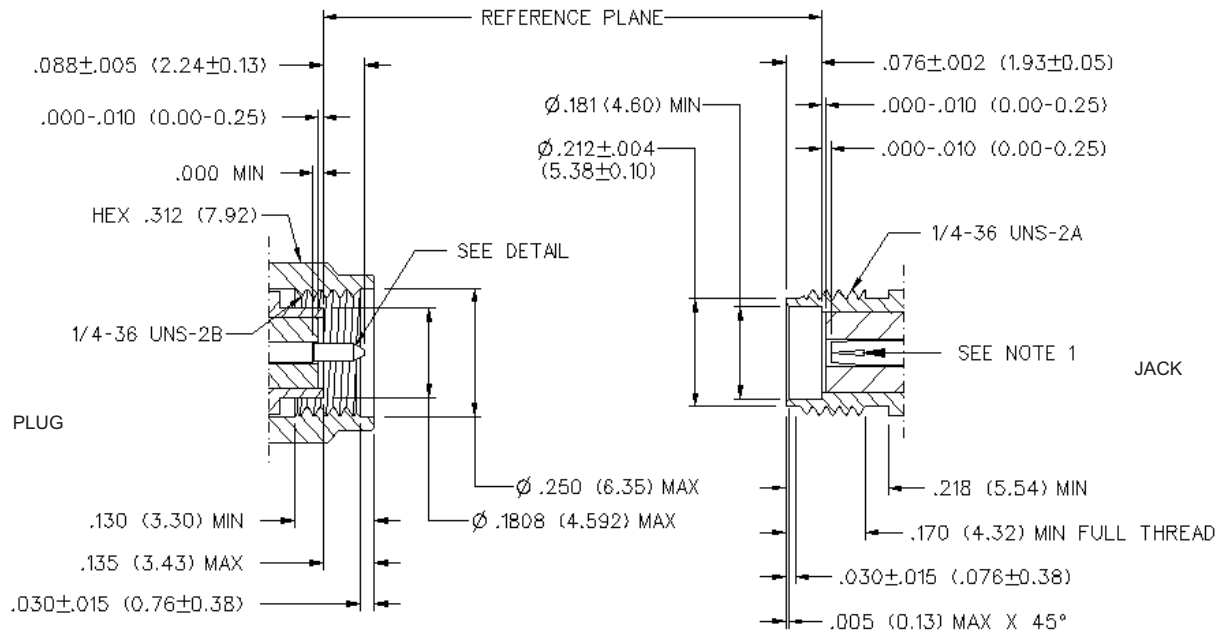

NOTES

1. ID OF CONTACT TO MEET VSWR, CONTACT RESISTANCE AND INSERTION WITHDRAWAL FORCES WHEN MATED WITH DIA .0355-.0370 MALE PIN.