

## Technical Specification for Optical Transceiver Module

### SCM7302-XC

### SCM7302-GC

- |  |   |  |
|--|---|--|
| <input type="checkbox"/> 155.52Mbps            | <input checked="" type="checkbox"/> 622.08Mbps                | <input type="checkbox"/> other _____                                     |
| <input checked="" type="checkbox"/> Short Haul | <input type="checkbox"/> Long Haul                            | <input type="checkbox"/> other _____                                     |
| <input type="checkbox"/> Intermediate Reach    | <input type="checkbox"/> Long Reach                           | <input type="checkbox"/> other _____                                     |
| <input type="checkbox"/> Single 5.0 V          | <input checked="" type="checkbox"/> Single 3.3 V              | <input type="checkbox"/> other _____                                     |
| <input checked="" type="checkbox"/> 1.3 μm     | <input type="checkbox"/> 1.55 μm                              | <input type="checkbox"/> other _____                                     |
| <input type="checkbox"/> Transmitter           | <input type="checkbox"/> Receiver                             | <input checked="" type="checkbox"/> Transceiver                          |
|  | ( <input type="checkbox"/> 2R / <input type="checkbox"/> 3R ) | ( <input type="checkbox"/> 2R / <input checked="" type="checkbox"/> 3R ) |



SUMITOMO Electric reserves the right to make changes in the specification described here-  
inafter without prior notice.

-----  
#Safety Precaution Symbols This specification uses various picture symbols to prevent possible injury to operator or other persons or damage to properties for appropriate use of the product. The symbols and definitions are as shown below. Be sure to be familiar with these symbols before reading this specification.

- |  |
|--|
| <b>Warning</b> Wrong operation without following this instruction may lead to human death or serious injury.   |
| <b>Caution</b> Wrong operation without following this instruction may lead to human injury or property damage. |

Example of picture symbols indicates prohibition of actions. Action details are explained nearby.  
 indicates compulsory actions or instructions. Action details are explained near by.

## 1. General

SCM7302-GC is a series of compact and high speed performance digital optical transceiver module ideally designed for versatile high speed network applications. 1300nm high speed InGaAsP-LD and InGaAs PIN-PD are provided as a light source and a detector, respectively. Transceiver module has PC board mountable package with electrical and optical interfaces.

* Data Rate	622.08Mbps, NRZ
* Duty Cycle	50%
* Power Supply Voltage	Single+3.3V
* Electrical Interface	PECL
* Fiber Coupled Power	-8 ~ -15dBm (Typ. -11dBm) into SMF
* Input Power Range	-8 ~ -28dBm (Typ. Sensitivity -32dBm)
* Connector Interface	SC Duplex Connector

The features of SCM7302-GC are listed below.

* Features	Low Power Supply Voltage / Low Power Consumption Plastic Molded Package Multi-sourced Footprint
Transmitter.....	Uncooled Laser with Automatic Power Control IC Optical Output Shut-down (Disable) Laser Bias Current Monitor / Rear Facet Monitor Class 1 Laser Product (IEC 825-1 and FDA 21 CFR 1040.10 and 1040.11)
Receiver.....	Wide Dynamic Range Built-in Clock Recovery (utilizing a SAW filter) ITU-T G.957 / G.958 and Bellcore TA-NWT-000253 Compliant Signal Detect (FLAG) Function

## 2. Block Diagram

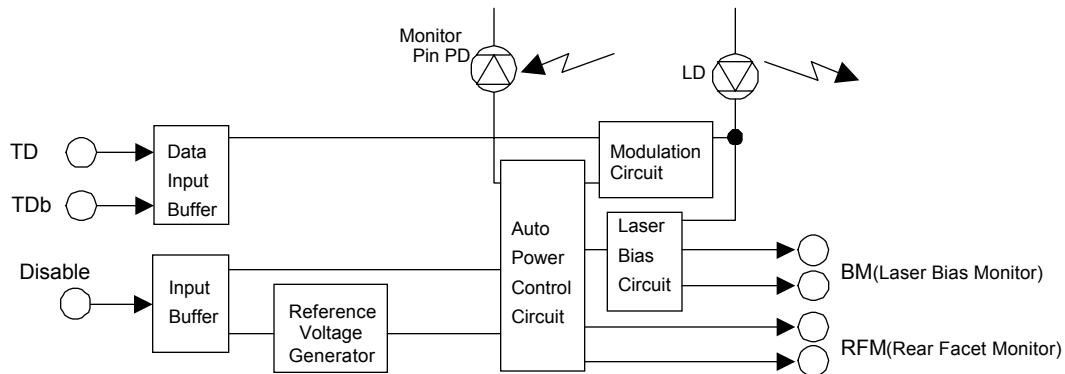

Figure 1-1. Block Diagram (Transmitter)

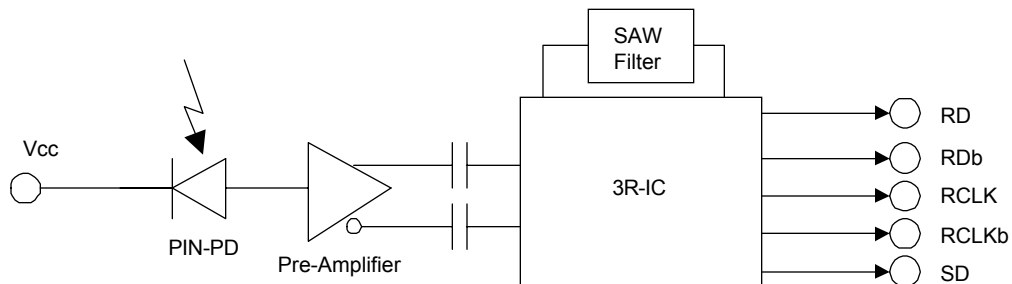

Figure 1-2 Block Diagram (Receiver)

### 3. Package Dimension

All dimensions are in mm.

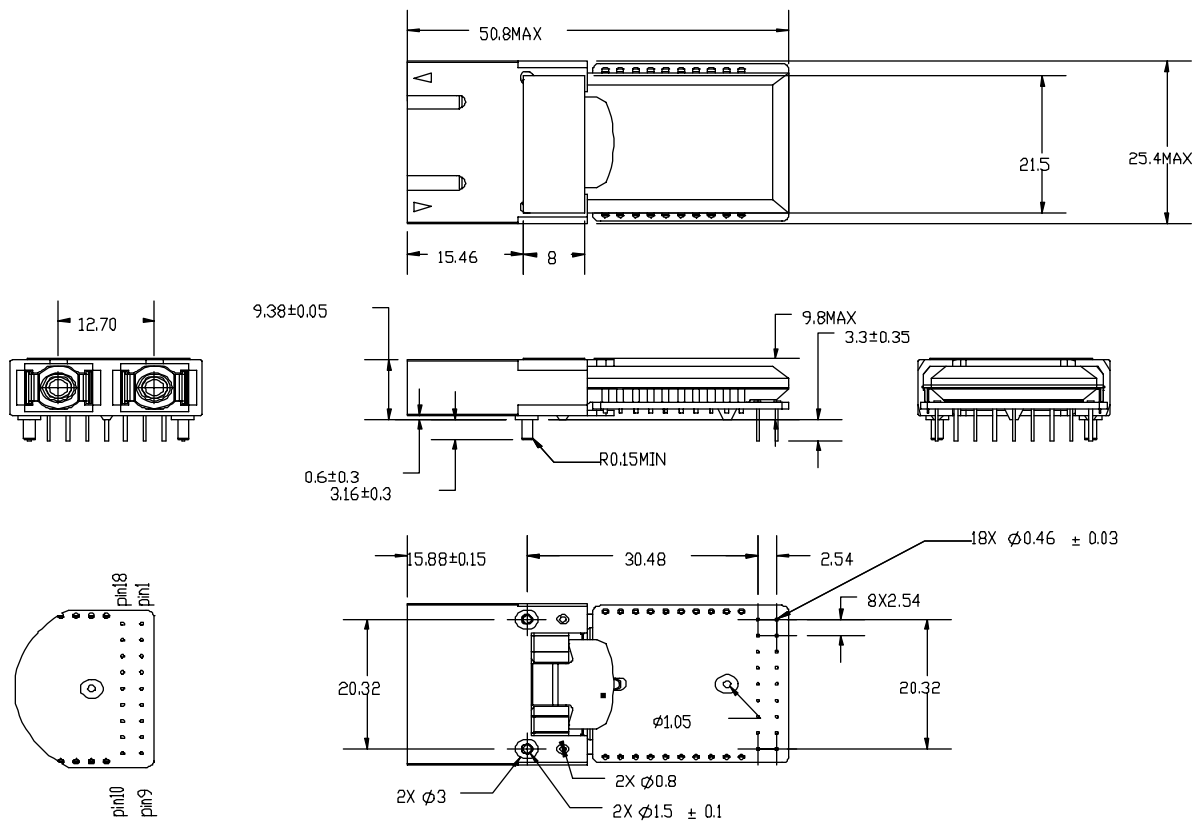

Figure2-1. Outline Dimensions(SCM7302-XC)

All dimensions are in mm.

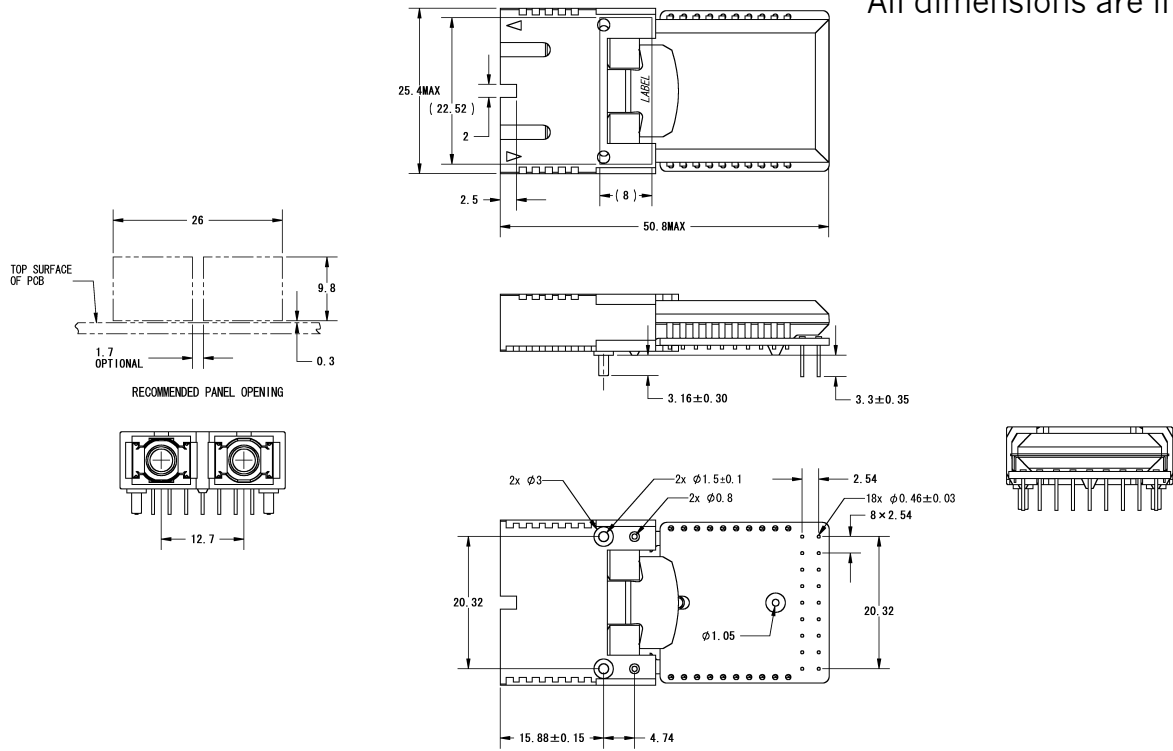
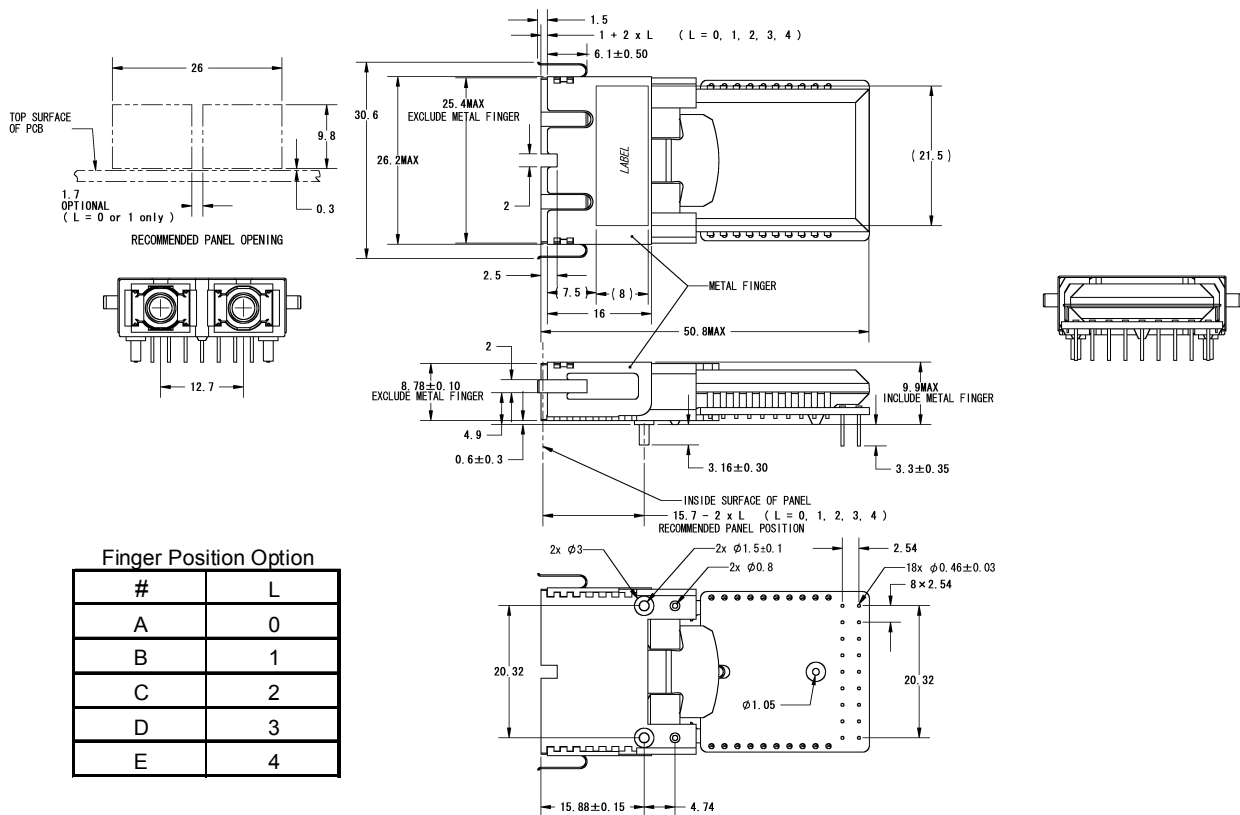

Figure2-2. Outline Dimensions (SCM7302-GC-ZN / SCM7302-GC-ZW)



Finger Position Option

#	L
A	0
B	1
C	2
D	3
E	4

Figure2-3. Outline Dimensions (SCM7302-GC-#N / SCM7302-GC-#W)

(SCM7302-XC, SCM7302-GC)

**⚠ Caution**

Do not disassemble this product. Otherwise, failure, electrical shock, overheating or fire may occur.  
Handle the lead pin carefully. Use assisting tools or prospective aids as required. A lead pin may injure skin or human body

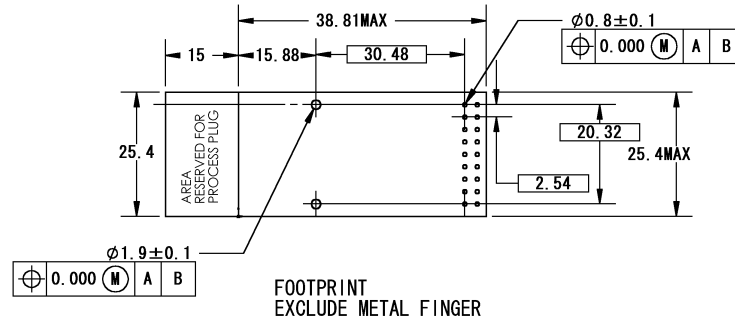

Figure2-4.RecommendedFootprint

## 4. Pin Assignment

No.	Symbol	Function
1	NC	No User Connection
2	NC	No User Connection
3	RCLKb	Differential Clock Output (Negative)
4	RCLK	Differential Clock Output (Positive)
5	BM(-)	Monitoring pin for LD Bias Monitor
6	BM(+)	Monitoring pin for LD Bias Monitor
7	Disable	LD Disable Input
8	RFM(+)	Monitoring pin for Rear Facet Monitor
9	RFM(-)	Monitoring pin for Rear Facet Monitor
10	Veetx	Power Supply (-) for Transmitter : Connected to GND
11	TD	Transmitter Differential Data (Positive)
12	TDb	Transmitter Differential Data (Negative)
13	Vcctx	Power Supply (+) for Transmitter : Connected to +3.3V
14	Vccrx	Power Supply (+) for Receiver : Connected to +3.3V
15	SD	Signal Detect (FLAG)
16	RDb	Received Differential Data (Negative)
17	RD	Received Differential Data (Positive)
18	Veerx	Power Supply (-) for Receiver : Connected to GND

NC pins should left open for additional functions in the future

## 5. Absolute Maximum Ratings

Parameter	Symbol	min.	Max	Unit	Note
Storage Case Temperature	Ts	-40	85	°C	1
Operating Case Temperature	Tc	-5	70	°C	1, 2
		-40	85	°C	1, 3
Supply Voltage	Vcc-Vee	0.0	4.0	V	4
Input Voltage	Vi	Vee	Vcc+0.5	V	5
Lead Soldering (Temperature) (Time)			260	°C	6
			10	sec.	

Note 1. No condensation allowed. 2. SCM7302-GC 3. SCM7302-GC-W 4. Vcc>Vee, Vcc=+3.3V, Vee=GND  
5. TD, TDb, Disable 6. Measured on lead pin at 2mm (0.079in.) off the package bottom

### ⚠ Warning

❗ Use the product with the rated voltage described in the specification. If the voltage exceeds the maximum rating, overheating or fire may occur.

### ⚠ Caution

⊘ Do not store the product in the area where temperature exceeds the maximum rating, where there is too much moisture or dampness, where there is acid gas or corrosive gas, or other extreme conditions. Otherwise, failure, overheating or fire may occur.

## 6. Electrical Interface

(Unless otherwise specified, Vcc-Vee = 3.14 to 3.47 V and all operating temperature shall apply.)

### 6-1. Transmitterside

Parameter	Symbol	min.	Typ.	Max.	Unit	Note
Supply Voltage	Vcc-Vee	3.14	3.30	3.47	V	
Supply Current	Idtx		70	140	mA	1, 2, 3
Input Voltage TD, TDb	High	Vih	Vcc-1.17	Vcc-0.73	V	4, 5
	Low	Vil	Vcc-1.95	Vcc-1.45		
Input Current TD, TDb	High	Iih	-10	150	μA	4, 5
	Low	Iil	-10	10		
Signal Input Rise / Fall Time				0.5	nsec.	6
Disable Input Voltage	Vdi	Vee+2.0		Vcc	V	7
Disable Input Current	Idi	-10	140	200	μA	
LD Bias Monitor Voltage	Vbm	0.01		0.50	V	5, 8
Rear Facet Monitor Voltage	Vrfm	0.01		0.20	V	5, 8

Note 1. Input bias current is not included. 2. 50% duty cycle data  
3. 622.08Mbps 4. Vcc-Vee=3.3V 5. Tc=25°C 6. 20~80%  
7. The transmitter is enabled as default state and requires an external voltage only to disable. (Refer to Section 8. Relation between Disable Input Voltage and Optical Output Power)  
8. The Laser Bias and Rear Facet Monitor currents are calculated as ratios of the corresponding voltages across the current-sensing resistors, 10Ω and 200Ω, respectively (See Figure 3). Upon measuring or utilizing these values, please use a device whose impedance is high enough (>1MΩ) compared with those resistors.

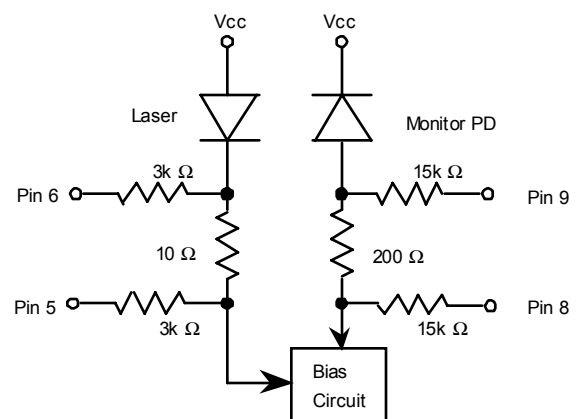

Figure 3 Monitor Circuit Schematic Diagram

6-2. Receiver side

Parameter	Symbol	min.	Typ.	Max.	Unit	Note
Supply Voltage	Vcc-Vee	3.14	3.30	3.47	V	
Supply Current	I <sub>drx</sub>		115	160	mA	1,2
Data & Clock Output Voltage	High	V <sub>oh</sub>	V <sub>cc</sub> -1.10	V <sub>cc</sub> -0.86	V	3
	Low	V <sub>ol</sub>	V <sub>cc</sub> -1.86	V <sub>cc</sub> -1.50	V	
FLAG Output Voltage	High	V <sub>oh</sub>	2.40	V <sub>cc</sub>	V	4
	Low	V <sub>ol</sub>	V <sub>ee</sub>	0.40	V	
Clock Rise / Fall Time	T <sub>rc</sub> / T <sub>fc</sub>			700	psec.	5
Data Rise / Fall Time	T <sub>rd</sub> / T <sub>fd</sub>			1000	psec.	
SD Assert Time	T <sub>a</sub>			1000	μsec	6
SD Deassert Time	T <sub>d</sub>	2.3		100	μsec	
Clock Sampling Point	T <sub>csp</sub>	0.6	0.7	0.8	nsec.	7
Clock Jitter (rms)	T <sub>jc</sub>			16	psec.	2, 3, 8
Clock Duty	C <sub>duty</sub>	45	50	55	%	
Data Jitter (rms)	T <sub>jd</sub>			40	psec.	

Note 1. Output current is not included.

2. Measured at the bit rate of 622.08Mbps, PRBS 2<sup>23</sup>-1, NRZ

3. V<sub>cc</sub>=+3.3V, T<sub>c</sub>=25°C, Output load resistance R<sub>l</sub>=50Ω to V<sub>cc</sub>-2V for RD, RDb, RCLK and RCLKb

4. CMOS interface

5. 20~80%, Input capacitance and stray capacitance of measuring devices should be less than 2pF

6. Refer to Figure 5.

7. Phase difference between cross point of RD and rising edge of RCLK. Refer to Figure 4.

8. Optical Input Power: -28.0 ~ -8.0dBm

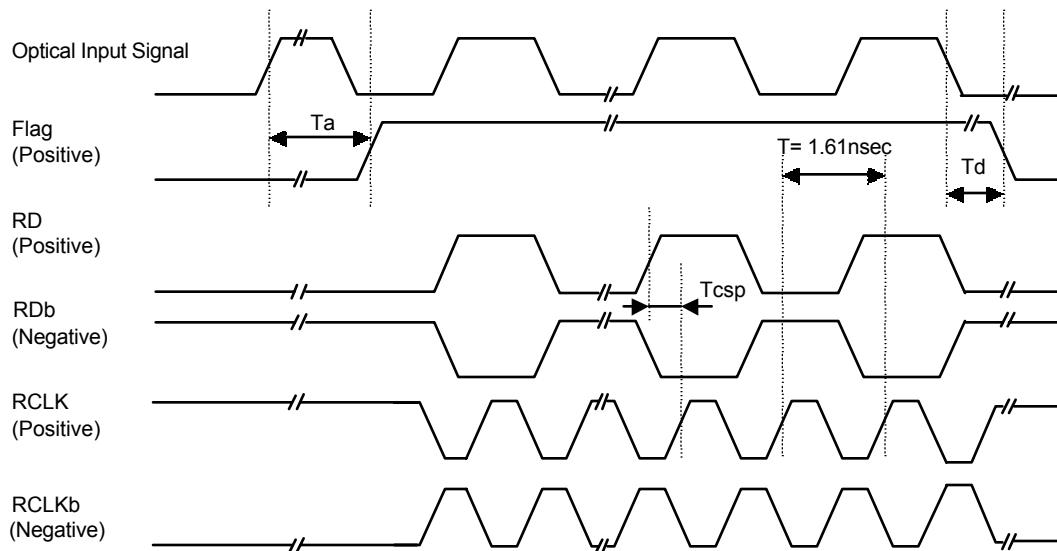

Figure 4. Timing Chart

## 7. Optical Interface

( Unless otherwise specified, Vcc-Vee = 3.14 to 3.47 V and all operating temperature shall apply. )

### 7-1. Transmitterside

Parameter	Symbol	min.	Typ.	Max.	Unit	Note
Average Output Power	Po	-15.0		-8.0	dBm	1
Extinction Ratio	Er	8.2			dB	1
Center Wavelength	$\lambda_c$	1274		1356	nm	
Spectral Width (RMS)	$\Delta\lambda$			2.5	nm	
Eye Mask for Optical Output	Refer to Figure 5					

Note 1. Measured at 622.08Mbps PRBS2\*23-1, 50% duty cycle data

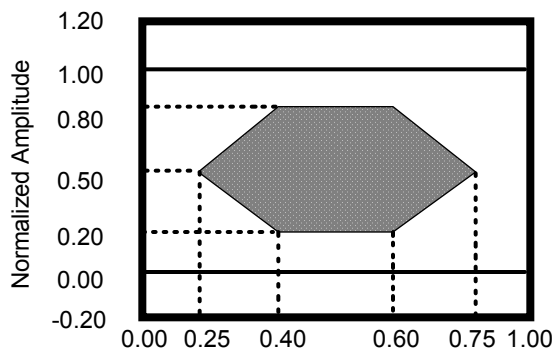

Figure 5 Optical Pulse Mask with Fourth Order Bessel-Thomson Filter Specified in ITU-T G.957

Relation between Input Signal and Optical Output Signal

Input Signal		Optical Output Signal
TD	TDb	
High	Low	ON (High)
Low	High	OFF (Low)
High	High	Undefined
Low	Low	Undefined

### ⚠ Warning

⊘ Do not look at the laser beam projection area (e.g. end of optical connector) with naked eyes or through optical equipment while the power is supplied to this product. Otherwise, your eyes may be injured.

### 7-2. Receiver side

Parameter	Symbol	min.	Typ.	Max.	Unit	Note
Bit Rate Range	-	622.08 +/- 50ppm			Mbps	
Center Wavelength	-	1261		1580	nm	
Minimum Sensitivity	Pmin			-28.0	dBm	1, 2
Overload	Pmax	-8.0			dBm	1, 2
Consecutive Identical Digit	CID	72	100		bits	3
SD Assert Level	Pa	-50	-36.5	-28	dBm	2, 4
SD deassert Level	Pd	-50	-37.5	-28	dBm	

Note 1. BER=10<sup>-10</sup>

Note 2. Measured at the bit rate of 622.08Mbps, PRBS 2\*23-1, NRZ

Note 3. Optical Input Power: -28.0 ~ -8.0dBm, Duty 50% input signal

Note 4. Refer to Figure 4

## 8. Relation between Disable Input Voltage and Optical Output Power

Disable Input Voltage	Optical Output Power
"L" (Vee ~ Vee+0.4V)	Enabled
"H" (Vee+2.0 ~ Vcc)	Disabled (<-45dBm)

Note. Enabled for no Disable input (pin 7 opened)



## 9. Recommended Interface Circuit

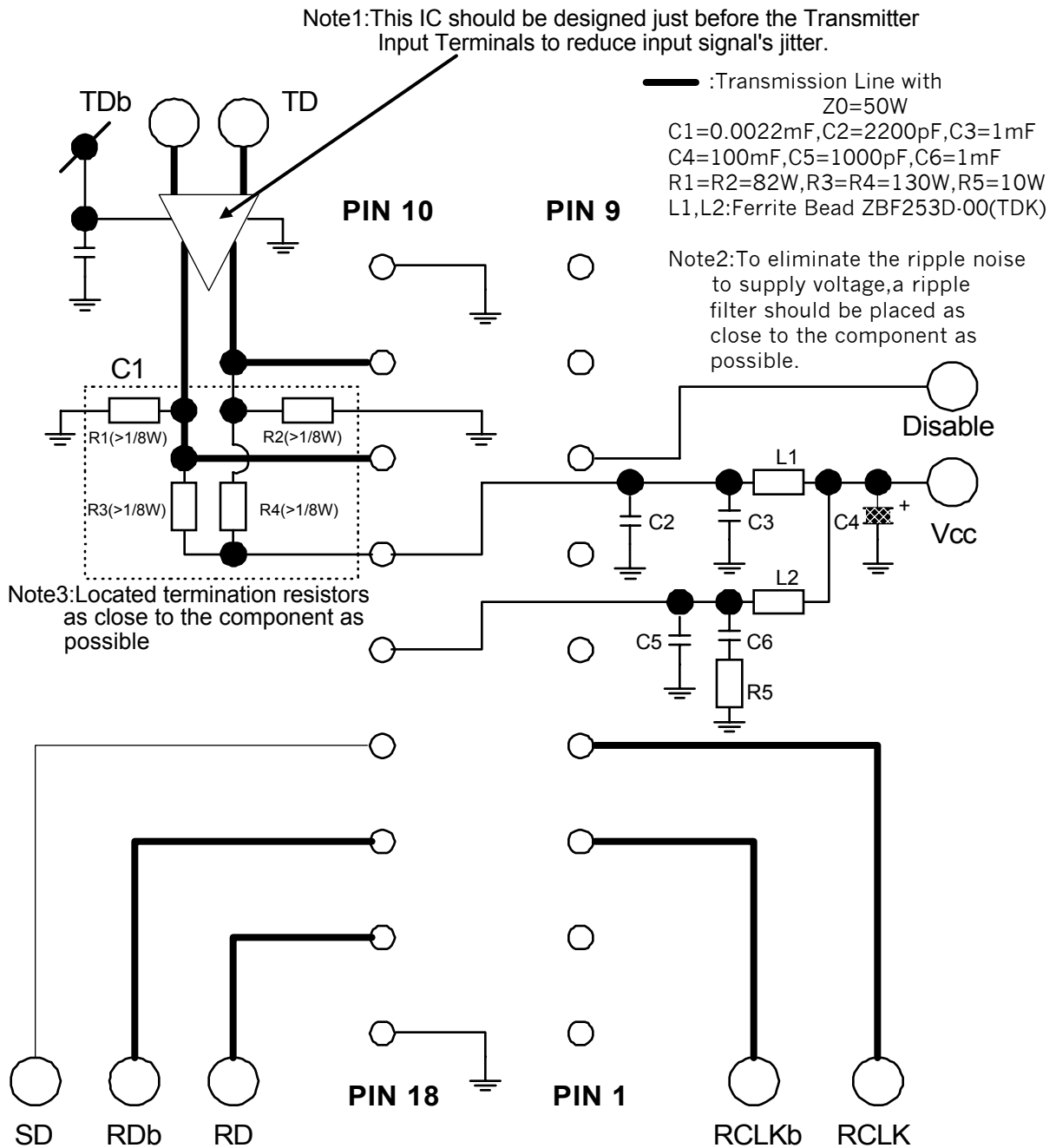

RD, RD<sub>b</sub>, RCLK, RCLK<sub>b</sub> are open emitter outputs.  
 Recommended line terminations for these outputs are shown below.

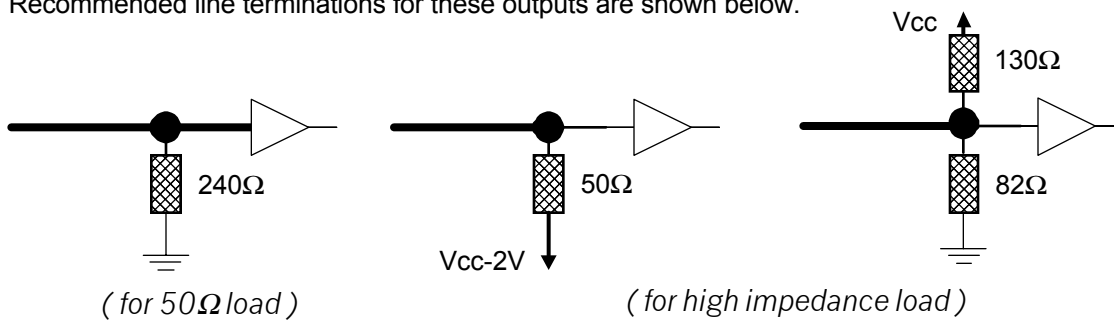

## 10. Reliability Test

GR-468-CORE Issue 1, December 1998 Laser Module

HEADING	TEST	REFERENCE	CONDITIONS	SAMPLING			ENV'T		Sumitomo Result	
				LTPD	SS	C	CO	RT/ UNC	SS	Pass/Fail
Mechanical Integrity	Mechanical Shock	MIL-STD-883 Method 2002	5 times/axis	20	11	0	R	R	----	----
			with TEC 500 G, 1.0ms w/o TEC 1,500G, 0.5ms	20	11	0	R	R	11	Pass
	Vibration	MIL-STD-883 Method 2007	Cond. A 20G, 20-2,000G Hz, 4min/cy, 4cy/axis	20	11	0	R	R	11	Pass
	Thermal Shock	MIL-STD-883 Method 1011	Delta T=100degC 0degC to 100degC	20	11	0	R	R	11	Pass
	Solderability	MIL-STD-883 Method 2003	(steam aging not required)	20	11	0	R	R	11	Pass
	Fiber Pull		1 kg; 3 times; 5 sec 2 kg; 3 times; 5 sec	20 20	11 11	0 0	R -	R O	---- 11	---- Pass
Endurance	Accel. Aging (High Temp.)	(R)-4-53 Section 5.18	70degC; rated power 2,000 hrs.	-	10	-	R	-	----	----
			5,000 hrs.	-	-	O	-	----	----	
			85degC; rated power 2,000 hrs.	-	25	-	R	25	Pass	
			5,000 hrs.	-	10	-	O	25	Pass	
	High Temp. Storage	-	max. storage T 2,000 hrs.	20	11	0	R	R	----	----
	Low Temp. Storage	-	min. storage T 2,000 hrs.	20	11	0	O	O	11	Pass
	Temperature Cycling	Section 5.20	-40degC to +70degC 100 pass/fail 500 for info.	20	11	0	R	-	----	----
-40degC to +85degC 500 pass/fail 1,000 for info.			-	11	-	R	-	----	----	
			20	11	0	-	R	11	Pass	
Damp Heat	MIL-STD-202 Method 103 or IEC-68-2-3	85degC/85%RH 1,000hrs. or 50degC/85%RH, 3,500 hrs.	20	11	0	R	R	11	Pass	
Cyc. Moist., Res.	Sec. 5.23	-	20	11	0	-	R	11	Pass	
Special Tests	Internal Moisture	MIL-STD-883 Method 1018	Max. 5,000ppm water vapour	20	11	0	R	R	11	Pass
	ESD Threshold	Section 5.22		-	6	-	R	R	6	----

LTPD (in %); min. acceptable sample size(SS) and corresponding number of allowed failures (C)

CO; Conditional Objective

RT/UNC; Room Temp. / Uncontrol

R; Requirement

O; Objective

## 11. Laser Safety

This product uses a semiconductor laser system and is a laser class 1 product acc. FDA, complies with 21CFR 1040.10 and 1040.11. Also this product is a laser class 1 product acc. IEC 60825-1.

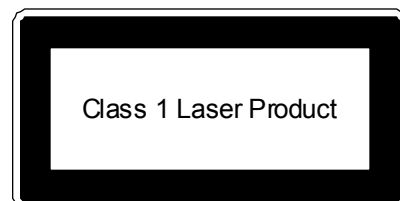

## 12. Other Precaution

Under such a strong vibration environment as in automobile, the performance and reliability are not guaranteed.

The governmental approval is required to export this product to other countries. To dispose of these components, the appropriate procedure should be taken to prevent illegal exportation.

This module must be handled, used and disposed of according to your company's safe working practice.

⚠ Warning	
❗	Be sure to carry out correct soldering for connection to peripheral circuits in order to prevent contact failure or short-circuit. Otherwise, a strong laser beam may cause eye injury, overheating or fire.
🚫	Do not put this product or components of this product into your mouth. This product contains material harmful to health.
⚠ Caution	
❗	Be sure to turn the power off when you touch this product connected to the printed circuit boards. Otherwise, electric shock may occur.
🚫	Dispose this product or equipment including this product properly as an industrial waste according to the regulations.

## 13. Ordering Information

Ordering Number	Connector type	Operating Temperature
SCM7302-XC	SC Duplex Connector	-5 ~ 70°C
SCM7302-XC-W	SC Duplex Connector	-40 ~ 85°C
SCM7302-GC-##	See chart below	

SCM7302-GC-##

└ Operating Case Temperature Option

N : -5°C ~ -70°C

W : -40°C ~ 85°C

└ EMI Shield Finger Option

Z : Without Finger

A ~ E : With Finger

(Letter specifies finger position. Refer to Figure2-3 for detail.)

## 14. For More Information

### U.S.A.

ExcelLight Communications, 4021 Stirrup Creek Drive, Suite 200 Durham, NC 27703

Tel. +1-919-361-1600 / Fax. +1-919-361-1619

E-mail: [info@excelight.com](mailto:info@excelight.com)

<http://www.excelight.com>

### Europe

Sumitomo Electric Europe Ltd., 220, Centennial Park, Elstree, Herts, WD6 3SL, United Kingdom

Tel. +44-208-953-8681

Fax. +44-208-207-5950

<http://www.sumielectric.com>

### Japan

Sumitomo Electric Industries, Ltd. ( International Business Division ), 3-12, Moto-Akasaka 1-chome

Minato-ku Tokyo 107-8468

Tel. +81-3-3423-5771 / Fax. +81-3-3423-5099

E-mail: [product-info@ppd.sei.co.jp](mailto:product-info@ppd.sei.co.jp)

<http://www.sei.co.jp/Electro-optic/index.html>