

KEYPAD + DISPLAY INTERFACE

RS232

SP3232EB

SIZE	DWG NO.		
B	090-0194		
SCALE	NONE	REV LTR	D
SHEET	2	OF	4

1/4/05

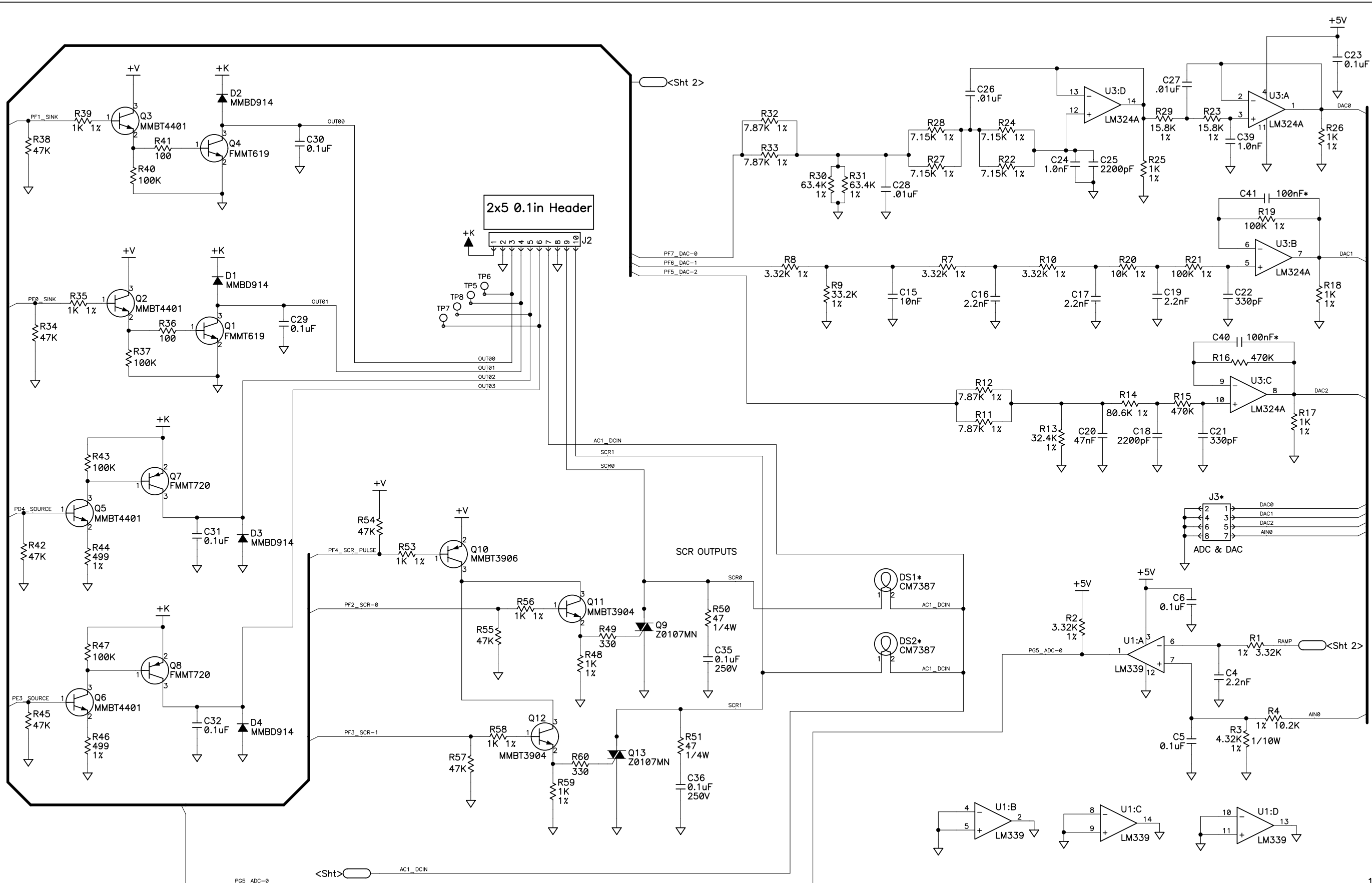

1/4/05

SIZE	DWG NO.		
B	090-0194		
SCALE	NONE	REV LTR	D
SHEET	3	OF	4

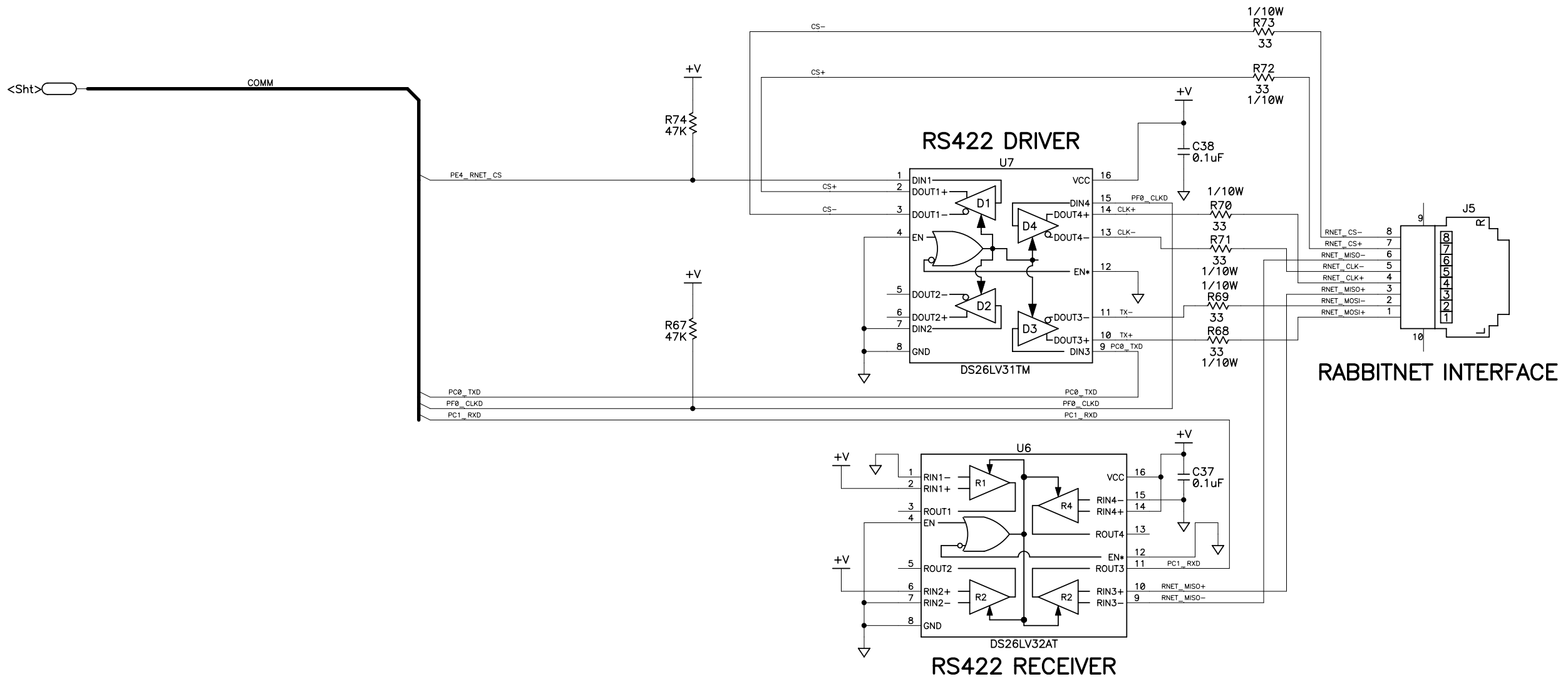

SIZE B	DWG NO. 090-0194
SCALE NONE	REV LTR D
SHEET 4 OF 4	