

PRODUCT NUMBER (SEE NOTE 7)	CONTACT PLATING		ROHS COMPATIBILITY
	SEPARABLE INTERFACE	PREE-FIT TAIL	
	10009542-001 10009542-001LF	0.76 μ m MIN GOLD OVER NICKEL	

A

B

C

D

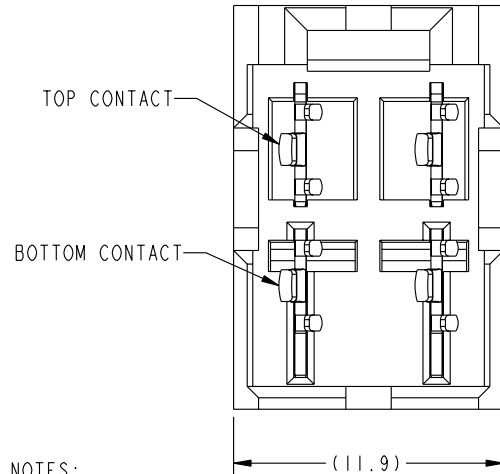

NOTES:

1. CONNECTOR MATERIALS:
HOUSING: HI TEMP THERMOPLASTIC, BLACK, UL94V-0 COMPLIANT.
CONTACT: HIGH PERFORMANCE COPPER ALLOY
2. CONTACT PLATING:
PRESS-FIT TAIL: 0.5-1.5 μ m TIN-LEAD OVER NICKEL (LEADED)
: 0.5-1.5 μ m MATTE TIN OVER NICKEL (LEAD FREE)
SEPARABLE INTERFACE: 0.76 μ m MIN GOLD OVER NICKEL
3. PRODUCT SPECIFICATION: GS-12-220
4. APPLICATION SPECIFICATION: GS-20-023
5. PRODUCT MARKING (PRODUCT NUMBER & LOT CODE) ON THIS SURFACE.
6. INDICATED HOLES ARE UNPLATED.
7. "LF" SUFFIX DENOTES LEAD FREE PLATING.
8. PRODUCT MEETS EUROPEAN UNION DIRECTIVES AND OTHER COUNTRY REGULATIONS AS DESCRIBED IN FCI SPECIFICATION GS-22-008.
9. PACKAGING MEETS FCI SPECIFICATION GS-14-920.
10. COPPER PLATING THICKNESS AT CENTER OF VIA HOLE CAN BE NO MORE THAN 0.003 LESS THAN OTHER AREAS.

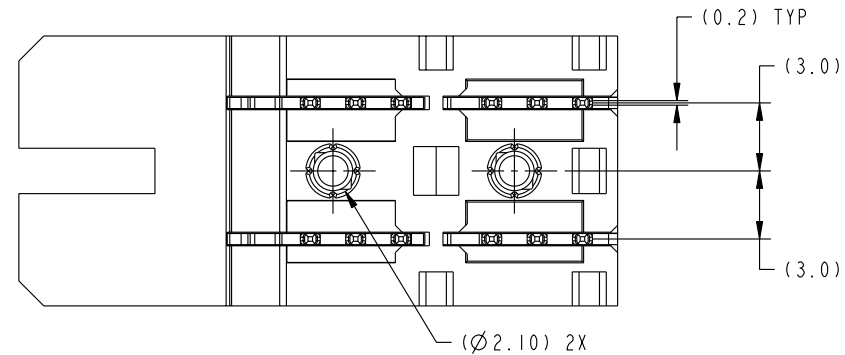
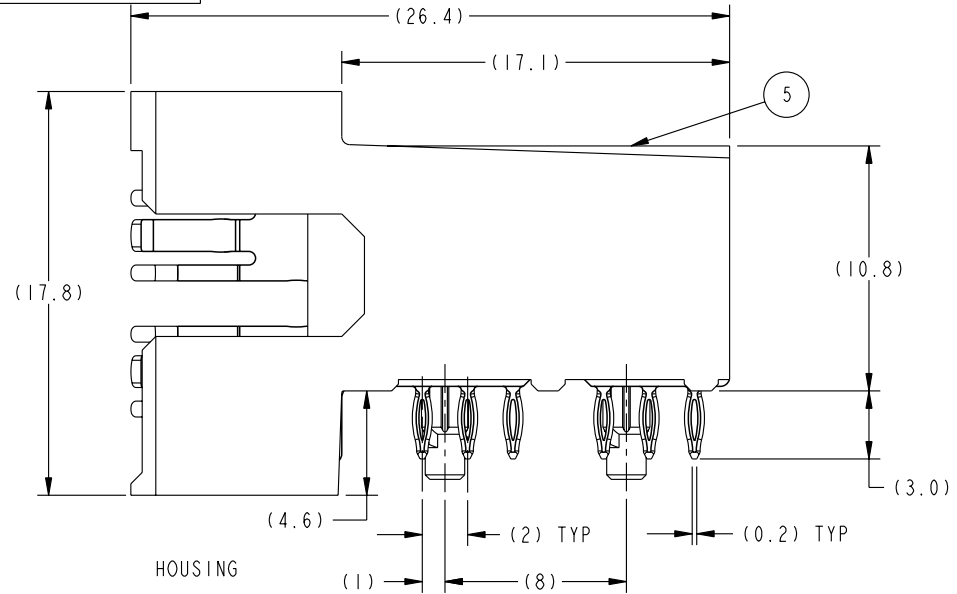

www.fciconnect.com			surface ASME Y14.5	tolerance std ASME Y14.5	projection MM
			TOLERANCES UNLESS OTHERWISE SPECIFIED		
Dr	T. BRUNGARD	2002-07-15	ANGULAR	0.X	±.3
Eng	T. BRUNGARD	2002-07-15	LINEAR	0.XX	±.13
Chr	C. H. TAN	2005-10-21	0°	0.XXX	±.051
Appr	JOEY NG	2005-10-21	Product family 2 mm HIGH POWER		size A4
					Scale 1:1
					ECN S06-0412
					Spec ref IN_WORK
FCI logo			2 X 2 HEADER ASSEMBLY, PRESS-FIT		dwg no 10009542
			catalog no		Rev. E
					sheet 1 of 2

TOP LAYER DESCRIPTION	TABLE I PLATED THROUGH-HOLE REQUIREMENTS							
	DRILLED HOLE DIAMETER	COPPER THICKNESS	TIN-LEAD THICKNESS	NICKEL THICKNESS	GOLD THICKNESS	TIN THICKNESS	SILVER THICKNESS	FINISHED HOLE DIAMETER
TIN-LEAD	0.81-0.86 (0.85 DRILL)	0.025 - 0.050	0.005 - 0.015	--	--	--	--	0.65 - 0.80
IMMERSION TIN	0.81-0.86 (0.85 DRILL)	0.025 - 0.050	--	--	--	0.9 - 1.5 um	--	0.70 - 0.80
IMMERSION SILVER	0.81-0.86 (0.85 DRILL)	0.025 - 0.050	--	--	--	--	0.15 - 0.65 um	0.70 - 0.80
COPPER (SEE NOTE 10)	0.81-0.86 (0.85 DRILL)	0.025 - 0.050	--	--	--	--	--	0.70 - 0.80
GOLD	0.81-0.86 (0.85 DRILL)	0.025 - 0.050	--	0.003 - 0.007	FLASH UP TO 0.0002	--	--	0.69 - 0.80

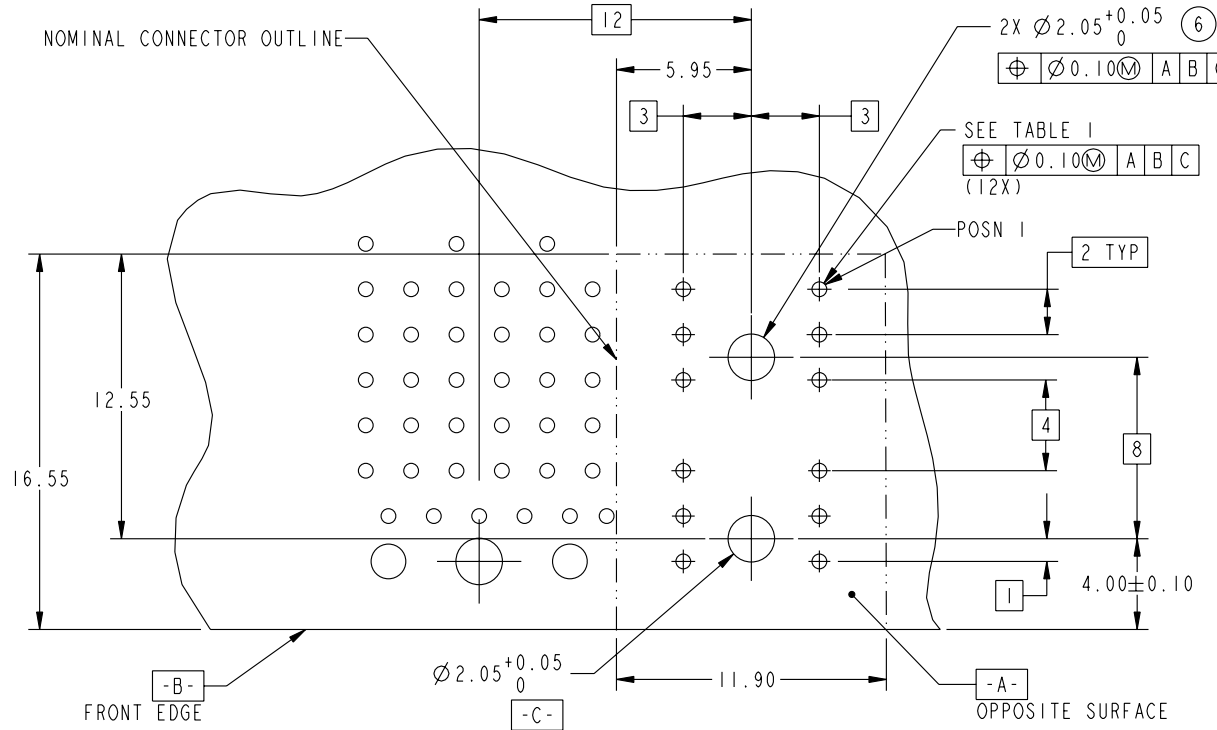

RECOMMENDED PCB LAYOUT,
COMPONENT SIDE
(SHOWN BESIDE A 5 ROW METRAL 1000 RECEPTACLE)

	TITLE	2 X 2 HEADER ASSEMBLY, PRESS-FIT	dwg no 10009542	Rev. E
	CATALOG NO	C		

