

1005/1013/8898

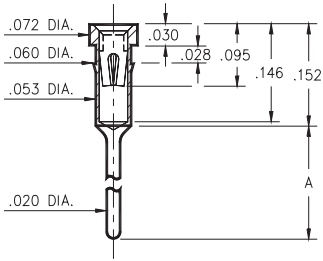

Basic Part Number	Length A
1005-0	.138
1013-0	.165
8898-0	.224

NOTE: 8898 is not annealed & not suitable for auto-clinching

XXXX-0-15-XX-3X-XX-04-0
Press-fit in .057 mounting hole
1/4 hard brass shell for auto-clinching

0145/0146

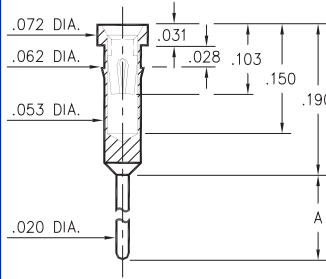

Basic Part Number	Length A
0145-0	.300
0146-0	.410

014X-0-15-XX-30-XX-04-0
Press-fit in .059 mounting hole

4378

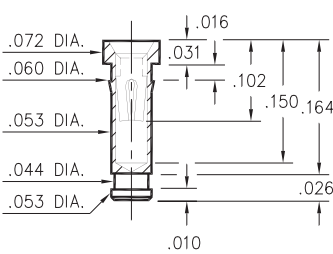

4378-0-15-XX-30-XX-10-0
Press-fit in .057 mounting hole

0556

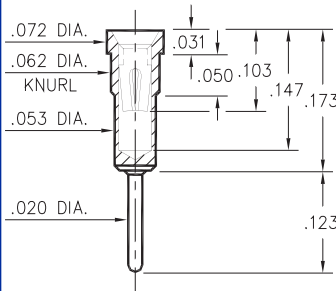

0556-0-15-XX-30-XX-04-0
Press-fit in .059 mounting hole

1103

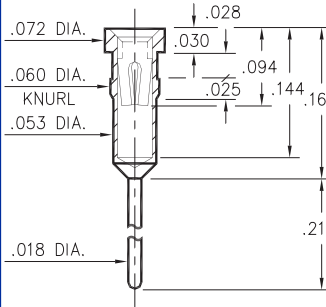

1103-0-15-XX-30-XX-04-0
Press-fit in .057 mounting hole

9234

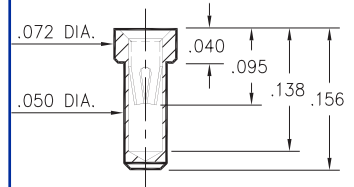

9234-0-15-XX-30-XX-10-0
Solder mount in .052 min. mounting hole

0136/37/38/39/41/48/52

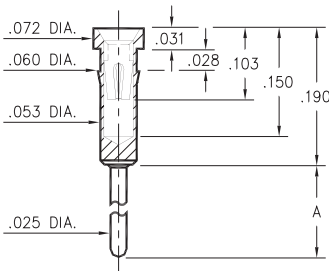

Basic Part Number	Length A
0136-0	1.215
0137-0	.560
0138-0	.210
0139-0	.635
0141-0	.700
0148-0	.455
0152-0	.410

01XX-0-15-XX-30-XX-04-0
Press-fit in .057 mounting hole

0447

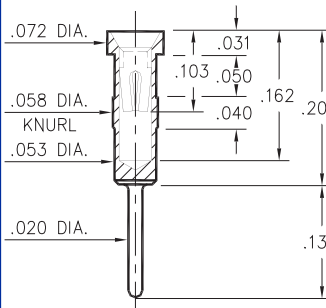

0447-0-15-XX-30-XX-04-0
Press-fit in .056 mounting hole

5660

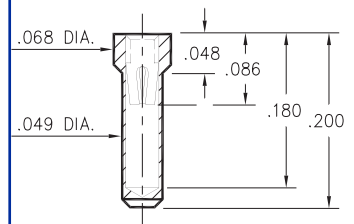

5660-0-15-XX-30-XX-10-0
Solder mount in .051 min. mounting hole

SPECIFICATIONS

SHELL MATERIAL:
Brass Alloy 360, 1/2 Hard

CONTACT MATERIAL:
Beryllium Copper Alloy 172, HT

DIMENSION IN INCHES
TOLERANCES ON:
LENGTHS: ±.005
DIAMETERS: ±.002
ANGLES: ± 2°

ORDER CODE: **XXXX - X - 15 - XX - 3X - XX - XX - 0**

BASIC PART #

SPECIFY SHELL FINISH:

- 01 200µ" TIN/LEAD OVER NICKEL
- 80 200µ" TIN OVER NICKEL
- 15 10µ" GOLD OVER NICKEL

SPECIFY CONTACT FINISH:

- 02 100µ" TIN/LEAD OVER NICKEL
- 84 100µ" TIN OVER NICKEL
- 27 30µ" GOLD OVER NICKEL

SELECT CONTACT

#30 or #32 CONTACT (DATA ON PAGE 208)

