

Small, High-Precision Switches  
Ideal for Gang Mounting

- Requires less operating force than conventional limit switches for improved precision
- Highly accurate repeatability to 0.01 mm (0.0004 inches)
- Prewired types with molded terminals available on special request
- Long service life, economical
- UL/CSA and CE approvals



## Ordering Information

### ■ STANDARD SWITCHES

Actuator type	Part number	Actuator type	Part number
Pin plunger	ZC-D55	Short hinge lever	ZC-W55
Panel mount plunger	ZC-Q55	Hinge lever	ZC-W155
Panel mount roller plunger	ZC-Q2255	Short hinge roller lever	ZC-W255
Panel mount cross roller plunger	ZC-Q2155	Hinge roller lever	ZC-W2155
Sealed roller plunger	ZC-N2255	One-way action short hinge roller lever	ZC-W355
Sealed cross roller plunger	ZC-N2155	One-way action hinge roller lever	ZC-W3155

Note: All models include a rubber seal.

### ■ ACCESSORIES

Description	Part number
Rubber seal	SC-R40

## Construction

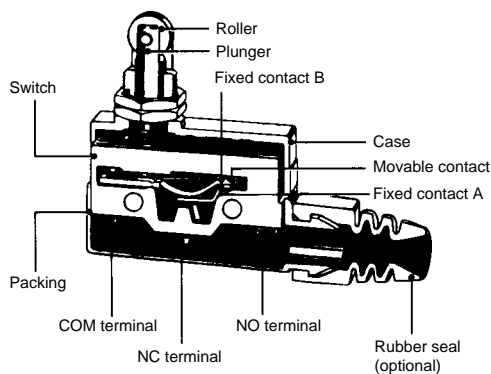

# Specifications

## ■ RATINGS

### Maximum Carrying Currents

Rated voltage	Non-inductive load (amps)				Inductive load (amps)				Inrush current (amps)	
	Resistive load		Lamp load		Inductive load		Motor load			
	NC	NO	NC	NO	NC	NO	NC	NO	NC	NO
125 VAC	10	10	3	1.5	10	10	5	2.5	30 max.	15 max.
250 VAC	10	10	2.5	1.25	10	10	3	1.5		
480 VAC	3	3	1.5	0.75	2.5	2.5	1.5	0.75		
8 VDC	10	10	3	1.5	6	6	5	2.5		
14 VDC	10	10	3	1.5	6	6	5	2.5		
30 VDC	6	6	3	1.5	5	5	5	2.5		
125 VDC	0.5	0.5	0.4	0.4	0.05	0.05	0.05	0.05		
250 VDC	0.25	0.25	0.2	0.2	0.03	0.03	0.03	0.03		

Note:

1. Inductive load has a power factor of 0.4 (AC) and a time constant of 7 msec (DC).
2. Lamp load has an inrush current of 10 times the steady-state current while motor load has an inrush current of 6 times the steady-state current.

## ■ CHARACTERISTICS

Enclosure rating	UL	—
	NEMA	Types 1, 2, 3, 4, 5, and 13 (-N models); Types 1, 2, 3 and 4 all others
	IEC 144	IP67 (-N models); IP60 all others
Mechanical life	10,000,000 operations minimum	
Ambient operating temperature	-10° to 80°C (14° to 176°F)	
Vibration	Malfunction durability	10 to 55 Hz, 1.5 mm (0.06 in) double amplitude
Shock	Malfunction durability	30 G for plunger types, 20 G for lever types
	Mechanical durability	100 G

## ■ OPERATING CHARACTERISTICS

**Legend:** OF = Operating Force (max.); RF = Reset Force (min.); OT = Overtravel (min.); PT = Pretravel;  
MD = Movement Differential (max.); OP = Operating Position

Part number	Description	OF	RF	OT	PT	MD	OP
ZC-D55	Pin plunger	1200 g (42.3 oz.)	500 g (17.6 oz.)	2.4 mm (0.094 in)	1.5 mm (0.059 in)	0.2 mm (0.008 in)	32.4 ±0.8 mm (1.29 ±0.03 in)
ZC-Q55	Panel mount pin plunger	1200 g (42.3 oz.)	500 g (17.6 oz.)	3 mm (0.118 in)	1.5 mm (0.059 in)	0.2 mm (0.008 in)	38.2 ±0.8 mm (1.50 ±0.03 in)
ZC-Q2255	Panel mount roller plunger	1200 g (42.3 oz.)	500 g (17.6 oz.)	3 mm (0.118 in)	1.5 mm (0.059 in)	0.2 mm (0.008 in)	47.4 ±0.8 mm (1.87 ±0.03 in)
ZC-Q2155	Panel mount cross roller plunger	1200 g (42.3 oz.)	500 g (17.6 oz.)	3 mm (0.118 in)	1.5 mm (0.059 in)	0.2 mm (0.008 in)	47.4 ±0.8 mm (1.87 ±0.03 in)
ZC-N2255	Sealed roller plunger	700 g (24.7 oz.)	170 g (6.0 oz.)	2.5 mm (0.098 in)	1.5 mm (0.059 in)	0.2 mm (0.008 in)	47.7 ±0.8 mm (1.87 ±0.03 in)
ZC-N2155	Sealed cross roller plunger	700 g (24.7 oz.)	170 g (6.0 oz.)	2.5 mm (0.098 in)	1.5 mm (0.059 in)	0.2 mm (0.008 in)	47.4 ±0.8 mm (1.87 ±0.03 in)
ZC-W55	Short hinge lever	400 g (14.1 oz.)	80 g (2.8 oz.)	6 mm (0.236 in)	5 mm (0.197 in)	1 mm (0.039 in)	29.5 ±1.2 mm (1.12 ±0.05 in)
ZC-W155	Hinge lever	280 g (9.9 oz.)	60 g (2.1 oz.)	8.4 mm (0.331 in)	7 mm (0.276 in)	1.4 mm (0.055 in)	29.5 ±1.2 mm (1.12 ±0.05 in)
ZC-W255	Short hinge roller lever	400 g (14.1 oz.)	80 g (2.8 oz.)	6 mm (0.236 in)	5 mm (0.197 in)	1 mm (0.039 in)	43 ±1.2 mm (29.5 ±0.05 in)
ZC-W2155	Hinge roller lever	280 g (9.9 oz.)	60 g (2.1 oz.)	8.4 mm (0.331 in)	7 mm (0.276 in)	1.4 mm (0.055 in)	43 ±1.2 mm (1.69 ±0.05 in)
ZC-W355	One-way action short hinge lever	400 g (14.1 oz.)	80 g (2.8 oz.)	6 mm (0.236 in)	5 mm (0.197 in)	1 mm (0.039 in)	53 ±1.2 mm (2.1 ±0.05 in)
ZC-W3155	One-way action hinge roller lever	280 g (9.9 oz.)	60 g (2.1 oz.)	8.4 mm (0.331 in)	7 mm (0.276 in)	1.4 mm (0.055 in)	53 ±1.2 mm (2.1 ±0.05 in)

# Engineering Data

## ■ ELECTRICAL SERVICE LIFE

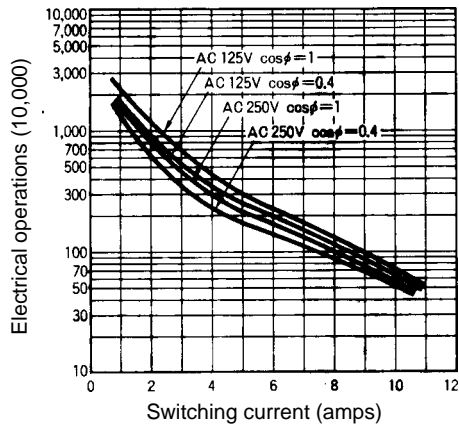

## ■ CONTACT RATINGS

10 A at 125 and 250 VAC  
 0.5 A at 125 VDC, 0.25 A at 250 VDC  
 NEMA A300C

## ■ CONTACT RESISTANCE

15 mΩ max. (initial)

## ■ ELECTRICAL APPROVALS

UL Recognized, File No. E76675

# Operation

## ■ CONTACT FORM

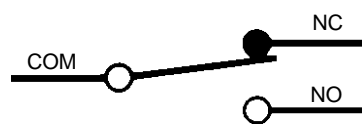

## ■ TERMINAL AND WIRE DESIGNATIONS

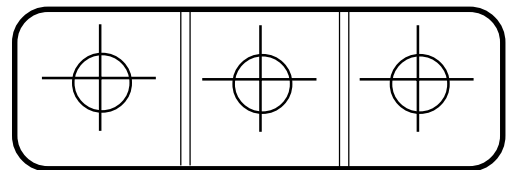

Standard  
 Prewired

COM  
 Black

NO  
 White

NC  
 Red

# Dimensions

Unit: mm (inch)

## ■ LIMIT SWITCHES

### ZC-D55 Pin Plunger Switch

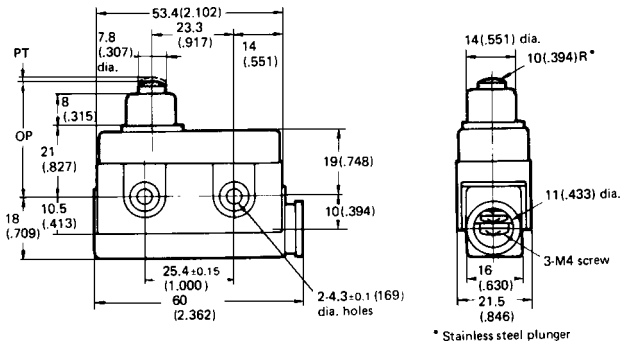
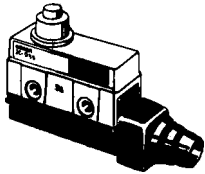

### ZC-Q55 Panel Mount Plunger Switch

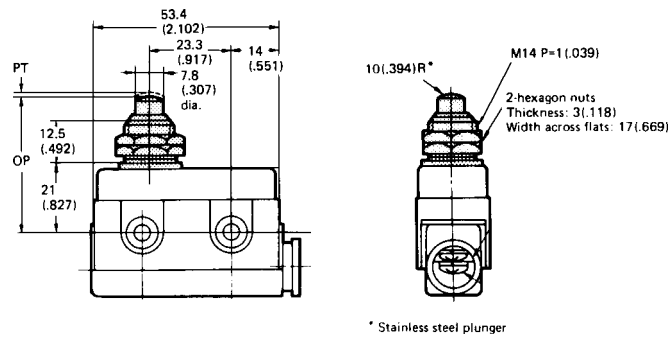
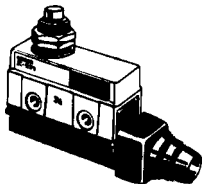

### ZC-Q2255 Panel Mount Roller Plunger Switch

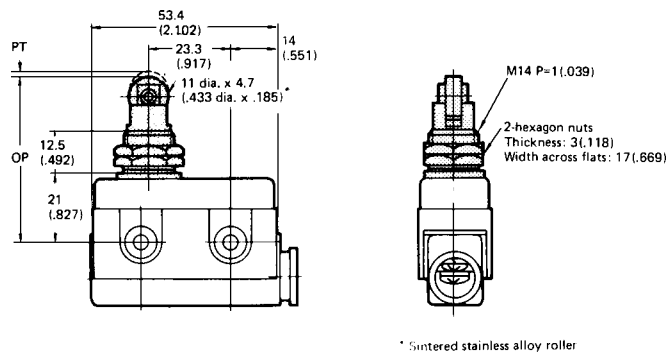
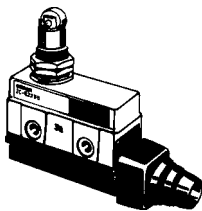

### ZC-Q2155 Panel Mount Cross Roller Plunger Switch

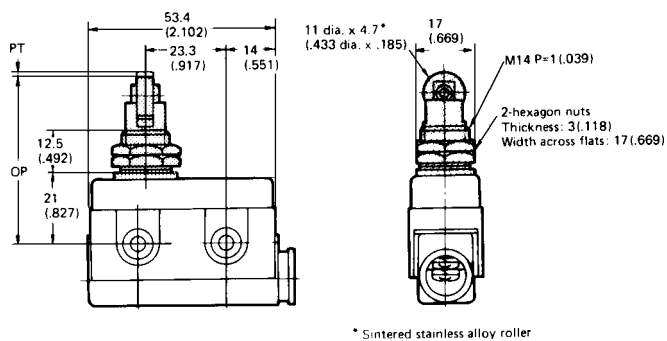
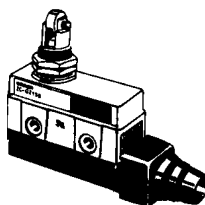

ZC-N2255 Sealed Roller Plunger Switch

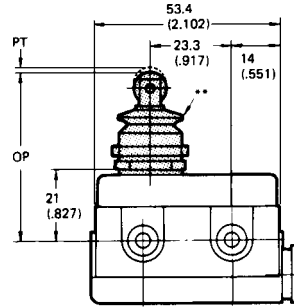
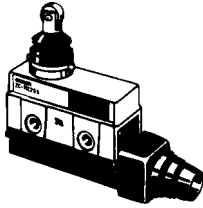

9.5 dia. x 4.7  
(.374 dia. x .185)\*



\* Sintered stainless alloy roller  
\*\* Rubber boot (N.B.R)

ZC-N2155 Sealed Cross Roller Plunger Switch

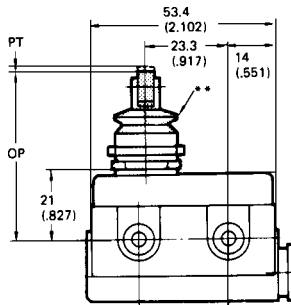
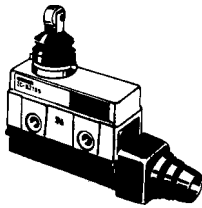

9.5 dia. x 4.7  
(.374 dia. x .185)\*

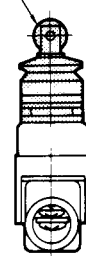

\* Sintered stainless alloy roller  
\*\* Rubber boot (N.B.R)

ZC-W55 Short Hinge Lever Switch

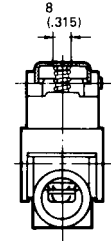
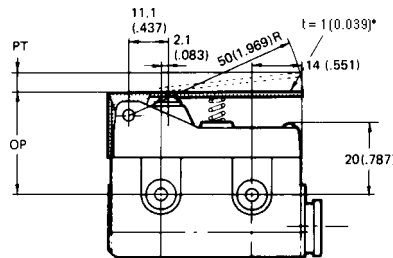
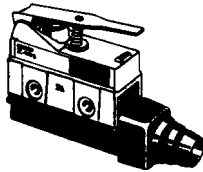

\* Stainless steel lever

ZC-W155 Hinge Lever Switch

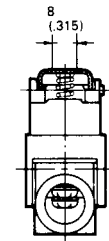
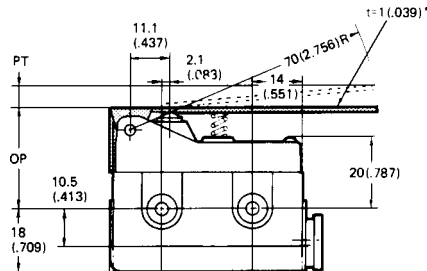
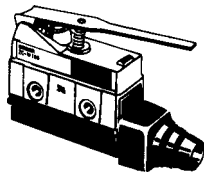

\* Stainless steel lever

Unit: mm (inch)

**ZC-W255 Short Hinge Roller Lever Switch**

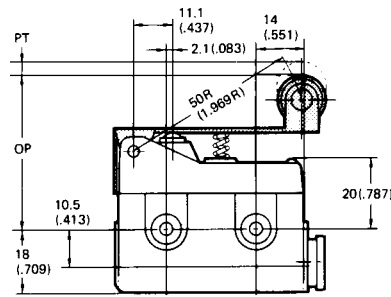
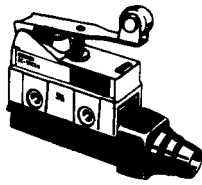

12.7 dia. x 7.5  
(.500 dia. x .295)

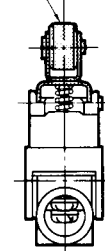

\* Stainless steel roller  
(Resin roller type is also available. Contact OMRON for detail.)

**ZC-W2155 Hinge Roller Lever Switch**

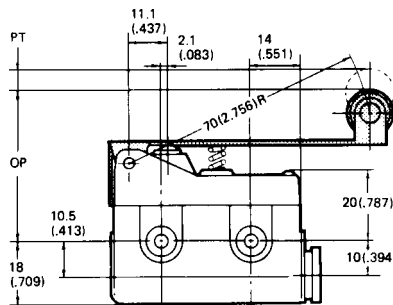
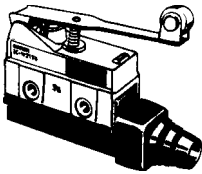

12.7 dia. x 7.5  
(.500 dia. x .295)\*

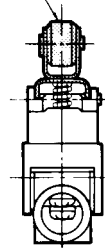

\* Stainless steel roller  
(Resin roller type is also available. Contact OMRON for detail.)

**ZC-W355 One-Way Action Short Hinge Roller Lever Switch**

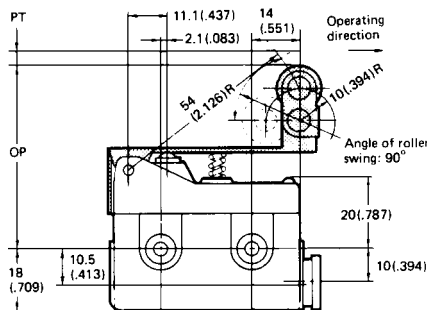
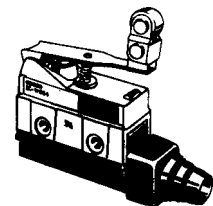

12.7 dia. x 7.5  
(.500 dia. x .295)\*

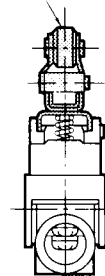

\* Stainless steel roller  
(Resin roller type is also available. Contact OMRON for detail.)

**ZC-W3155 One-Way Action Hinge Roller Lever Switch**

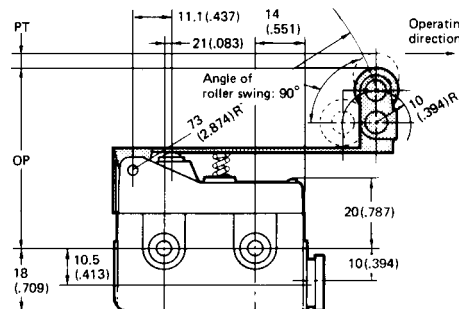
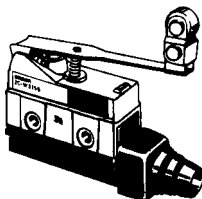

12.7 dia. x 7.5  
(.500 dia. x .295)\*

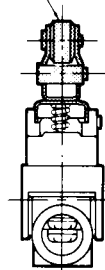

\* Stainless steel roller  
(Resin roller type is also available. Contact OMRON for detail.)

# Installation

---

## ■ MOUNTING HOLES

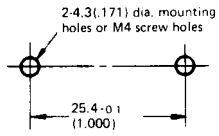

NOTE: DIMENSIONS ARE SHOWN IN MILLIMETERS. To convert millimeters to inches divide by 25.4.



**OMRON ELECTRONICS, INC.**

One East Commerce Drive  
Schaumburg, IL 60173  
**1-800-55-OMRON**

**OMRON CANADA, INC.**

885 Milner Avenue  
Scarborough, Ontario M1B 5V8  
**416-286-6465**