

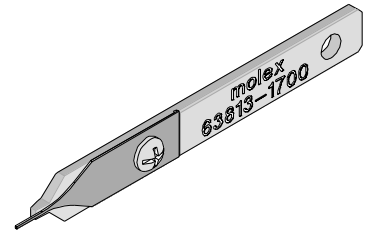

Extractor Tool Instruction Sheet

Order No. 63813-1700

(Japan No.578016-6000)



SCOPE:

This tool is used for the removal of 501193 terminals from 501189 series housing (1.00mm (.039") Pitch Wire-to-Board Female Housing).

Extractor Tool			
Order No.	Terminal No.	Housing No.	
63813-1700	501193-0000	501189-2010	501189-4010
	501193-0100	501189-3010	501189-5010

OPERATION:

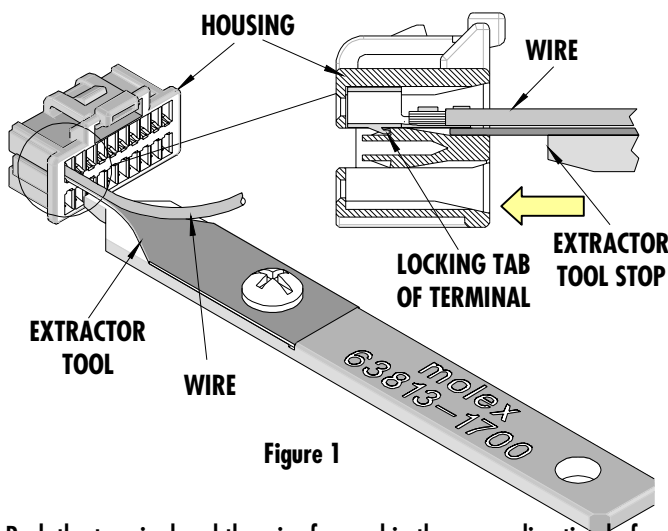

Figure 1

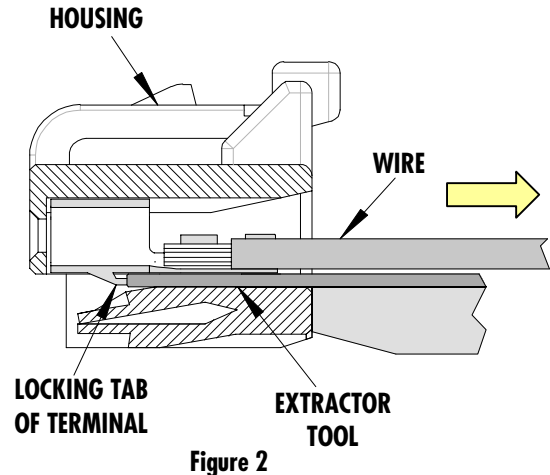

Figure 2

1. Push the terminal and the wire forward in the arrow direction before using the Extractor Tool. Insert the Extractor Tool into the slot below the terminal until the stop on the tool contacts the plastic housing as shown in Figure 1. This will flex the plastic lance freeing the terminal.

Note: Please do not forcefully insert, insert on an angle, or insert with twisting action. It may damage the tool or the housing.

2. Holding the wire and the tool together, pull the wire and the tool back through the connector slot in the arrow direction as shown in Figure 2.
3. Molex does not offer repair parts for Extractor Tools due to the inexpensive nature of the tool.

Americas Headquarters
 Lisle, Illinois 60532 U.S.A.
 1-800-78MOLEX
 amerinfo@molex.com

Far East North Headquarters
 Yamato, Kanagawa, Japan
 81-462-65-2324
 feninfo@molex.com

Far East South Headquarters
 Jurong, Singapore
 65-6-268-6868
 fesinfo@molex.com

European Headquarters
 Munich, Germany
 49-89-413092-0
 eurinfo@molex.com

Corporate Headquarters
 2222 Wellington Ct.
 Lisle, IL 60532 U.S.A.
 630-969-4550
 Fax: 630-969-1352

Visit our Web site at <http://www.molex.com>