

PART NUMBER: VPU-S200

DESCRIPTION: switching power supply

Features

- Universal input 85~264 Vac or 120~340 Vdc
- Power factor correction
- Output over-current protected
- Output over-voltage protected
- Remote sense
- Remote on/off
- Power good signal
- Efficiency up to 81%
- Safety approved to UL/cUL, TUV, CE
- Conducted EMI meets EN55022 class B and FCC class B

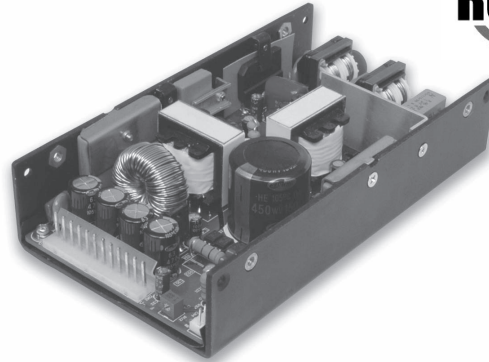

Model Configurations

Model	Voltage (Vdc)	Current (A)	Line Reg. ¹ (mV max)	Load Reg. ² (mV max)	Ripple & Noise ³ (mVp-p max)	Efficiency
VPU-S200-3.3	3.3	30	20	60	60	75%
VPU-S200-5	5	30	20	100	60	75%
VPU-S200-12	12	16.7	48	100	120	75%
VPU-S200-15	15	13.3	60	120	150	78%
VPU-S200-24	24	8.3	96	150	240	81%
VPU-S200-36	36	5.5	180	200	360	81%
VPU-S200-48	48	4.2	192	240	480	81%

Notes:

1. Measured from High Line to Low Line at Full load.
2. Measured from Full load to 10% load at 110 VAC.
3. Ripple & Noise measured at 20 MHz BW, with a 0.1 μ F ceramic cap and a 10 μ F electrolytic cap on the output.
4. Maximum 200W output continuous with 18CFM, except for VPU-S200-3.3 and VPU-S200-5, with maximum output of 30A respectively.

Derating Curves

1. Output Power vs. Ambient temperature

a. 3.3 and 5 V models

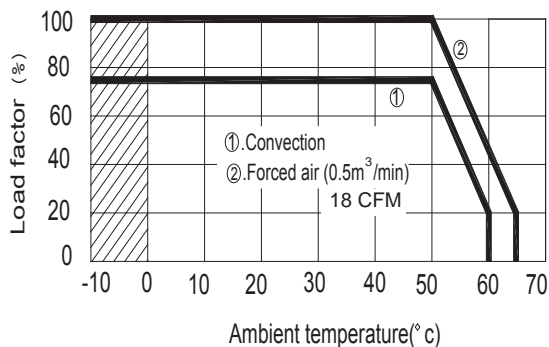

b. All other models

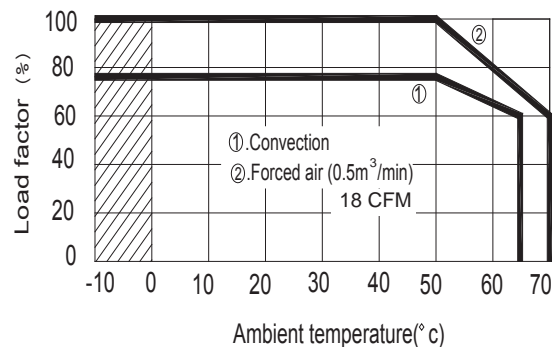

PART NUMBER: VPU-S200

DESCRIPTION: switching power supply

Input

Parameter	Conditions/Description	Min	Nom	Max	Units
Input Frequency		47		63	Hz
Input Voltage	Output power derated from 85-90 VAC	85		264	VAC
		120		340	VDC
Input Current	AC Input of 100 VAC		1400		mA
	AC Input of 200 VAC		700		mA
Inrush Current	Peak measured at 100 VAC at full load, cold start			20	A
	Peak measured at 200 VAC at full load, cold start			40	A
Power Factor	AC Input of 100 VAC, at full load		99		%
	AC Input of 200 VAC, at full load		95		%

Output

Parameter	Conditions/Description	Min	Nom	Max	Units
Efficiency	See Model Configurations.				
Start up time	At 85 VAC, full load			500	mS
Hold up time	At 115 VAC, full load	20			mS
Adjustability	Adjustable with built-in trim pot.	- 10		+10	%
Temp. Coefficient		-0.05		+0.05	%/°C

Logic/Analog Signals

Parameter	Conditions/Description
Remote Control	Remote On/Off function is controlled using pins REMO(2) and RTN(1) on logic connector CN4, in order to use the Remote On/Off function first connect jumper JP1 between pins 2 and 3 on JP1 on the power supply. A supply voltage of 3-15Vdc between the REMO(2) and RTN(1) pin on CN4 will activate the Remote On. Please note RTN(1) pin on CN4 is not in contact with -Vout or RTN(4) but can be shorted with no problems.
Power Good	Goes high 100-500 mS after the output reaches regulation. It goes low at least 1mS before loss of regulation.
Remote Sense	Remote sense terminals force regulation to where sensing terminals are connected.
RTN	Please note RTN(1) pin on CN4 is not in contact with -Vout or RTN(4) but can be shorted with no problems.

Fan Drive

Parameter	Conditions/Description
FanDrive	Provides 12V, 250mA to drive a DC fan. Minimum load is required on the power supply output for the voltage on the fan drive to be in regulation.

PART NUMBER: VPU-S200

DESCRIPTION: switching power supply

Protection Circuits

Parameter	Conditions/Description
Overload	Current limiting starts at 105% of the rated output current and recovers automatically.
Output Over-voltage	Output is protected against overvoltage. Unit shuts down at 115-140% of rated voltage.
Short Circuit	Protected. Long term short circuit may reduce reliability.
Input Under-voltage	Power supply shuts down when ac input is under 80 VAC. When ac line reappears over 86 +/- 5 VAC, the power supply restarts automatically.
Over temp.	Power supply shuts down when temperature is in excess of 85 °C. Auto recovery.

General and Safety

Parameter	Conditions/Description	Min	Nom	Max	Units
Switching frequency			100		KHz
Operating temp.	See derating curves.	-10		65	°C
Storage temp.		-20		75	°C
Operating humid.	Non-condensing	20%		90%	RH
Storage humid.	Non-condensing	20%		90%	RH
Operating altitude				3,000	m
				10,000	ft
Storage altitude				9,000	m
				30,000	ft
EMI	Conducted emissions comply with FCC class B, EN55022 class B				
Safety	Approved to UL/cUL 60950, TUV EN60950, CE, CB				
Leakage Current	Per EN60950, 264 VAC			1.5	mA
Isolation Voltage	Applied for 1 minute.				
(HI-POT)	Primary to secondary:	3000			VAC
	Primary to transformer core:	2000			VAC
	Primary to earth ground:	2000			VAC
Insulation Resistance	Measured at 500 VDC, at room temp.	50			MΩ
RoHS	Yes				
Warranty	Standard Warranty Length			2	years
MTBF	450,000 hours typ. per MIL-HDBK-217 at 25°C				

Mechanical

Parameter	Conditions/Description	Min	Nom	Max	Units
Dimensions	6.8"(172.7mm) x 3.8"(96.5mm) x 1.5"(38.1mm)				
Weight	without cover			900	g
Cooling method	Forced air for full load or convection cooling at derated load.				

Mating Connectors

Parameter	Conditions/Description
AC Input(CN1)	Molex Part No. 09-50-3051 or equivalent. Contact: Molex 2478 and 2578 series.
Output(CN2)	Molex Part No. 09-50-3121, Contact: Molex 2478 and 2578 series. Pin Assignments; Pin 1-6: Vo- Pin 7-12: Vo+
Fan(CN3)	JST XHP-2 or equivalent. Contact: SXH-001T-P06.
Logic(CN4)	JST XHP-6 or equivalent. Contact: SXH-001T-P06.

PART NUMBER: VPU-S200

DESCRIPTION: switching power supply

Application Notes:

Remote Sensing

(1.) When remote sensing is not used

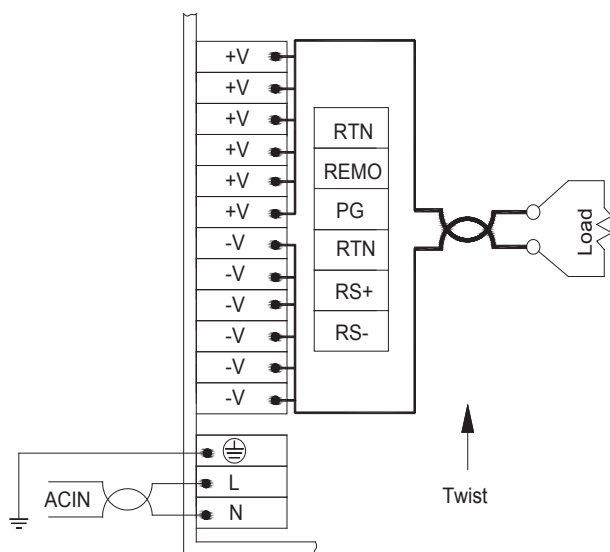

(2.) When remote sensing is used

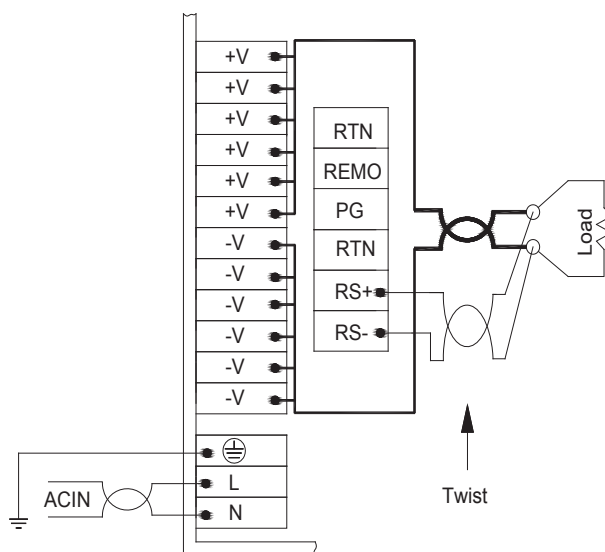

REV.	DESCRIPTION	DATE
A	NEW DRAWING	9/6/2006
B	corrected pin numbering	10/25/2007
C	added "THRU" designation and corrected hole dimensions	11/10/2008

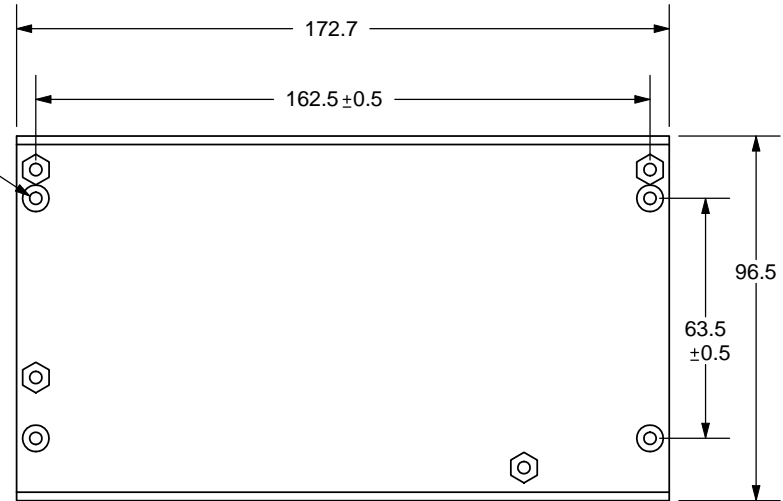
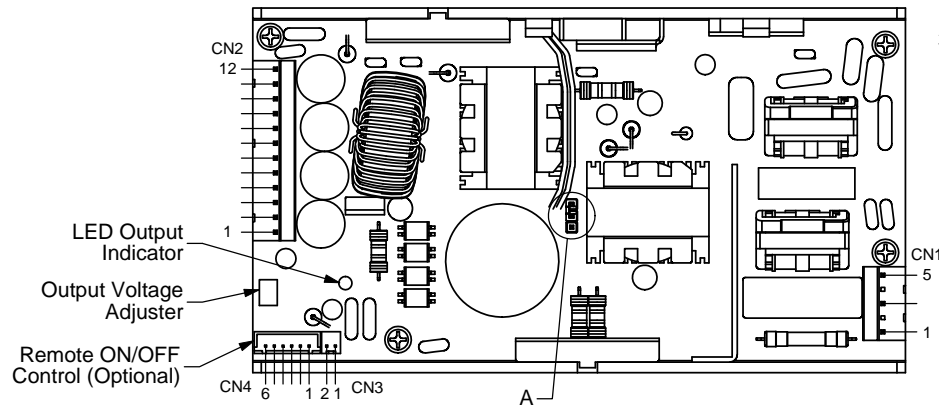
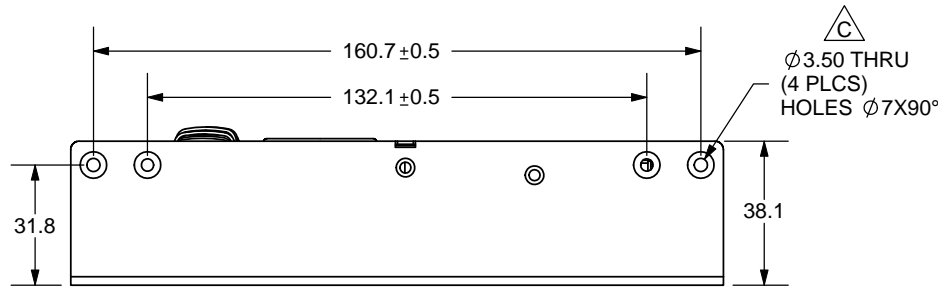

JP1 used for Remote On/Off control

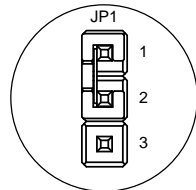

DETAIL A
SCALE 2 : 1

REMO: On/Off Control
 RTN: Return terminals for logic signals.
 Same electrical potential as -Vo.
 RS+: Remote Sense positive terminals.
 RS-: Remote Sense negative terminals.
 PG: Power good signal.

CN1	Pin Function	1	2	3	4	5							
		N	No Pin	L	No Pin	FG							
CN2	Pin Function	1	2	3	4	5	6	7	8	9	10	11	12
		-Vo	-Vo	-Vo	-Vo	-Vo	-Vo	+Vo	+Vo	+Vo	+Vo	+Vo	+Vo
CN3	Pin Function	1	2										
		FAN +	FAN -										
CN4	Pin Function	1	2	3	4	5	6						
		RTN	REMO	PG	RTN	RS+	RS-						

TOLERANCE:
 ±0.3mm UNLESS OTHERWISE SPECIFIED



20050 SW 112th Ave.
 Tualatin, OR 97062
 Phone: 503-612-2300
 800-275-4899
 Fax: 503-612-2383
 Website: www.cui.com

TITLE: SWITCHING POWER SUPPLY		REV: C
PART NO. VPU-S200		UNITS: MM [INCHES]
DRAWN BY: ZRJ	APPROVED BY:	SCALE: 1:2

PC FILE NAME:
 VPU-S200

COPYRIGHT 2008 BY CUI INC.