



VISHAY INTERTECHNOLOGY, INC.

OPTOELECTRONICS

SELECTOR GUIDE



INFRARED EMITTERS, PHOTO DETECTORS AND OPTICAL SENSORS



IR Emitters, Photo Detectors, and Optical Sensors



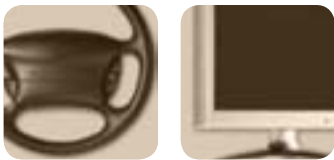
Introduction

As one of the world's leading suppliers of infrared emitters, photo detectors, and optical sensors, Vishay offers an extraordinarily broad portfolio of optoelectronic products. Whether you require the high speed of a PIN photodiode, the sensitivity of an ambient light sensor, or the object detection provided by a reflective or transmissive sensor, Vishay has a solution.

Behind these products stands a vertically integrated, optoelectronics company with over 30 years of experience in emitter and detector die fabrication and packaging know-how. Regional applications engineering and sales support is available wherever you are, be it in China, Korea, Singapore, Japan, Taiwan, North and South America, Europe, India or on-line via our web site.

Photo Detectors

Vishay has the broadest portfolio of PIN photodiodes on the market. With lower capacitance, they provide high-speed response, low noise and low dark current along with excellent sensitivity. They are ideal for high-speed data transfer, light barriers, alarm systems, and linear light measurement. In addition to PIN photodiodes, Vishay provides the industry's widest selection of phototransistors. Offered in over 12 different packages, Vishay's phototransistors are exceptionally sensitive and simplify circuit design by eliminating the need for a separate amplifier.



Infrared Emitters

Vishay offers emitters in more wavelengths than any other supplier: 830 nm, 850 nm, 870 nm, 885 nm, 940 nm, and 950 nm. Providing fast rise and fall response times, Vishay also has the broadest selection of double hetero infrared emitters. They are the highest-power infrared emitters with the lowest forward voltages on the market and ideal for high-current applications.



Optical Sensors

Whether your application involves detecting the edge of a sheet of paper, a spinning wheel, or an object's proximity, Vishay offers a solution with reflective and interrupter sensors. Offering thru-hole and surface mount packages, Vishay's portfolio meets the requirements of even the most demanding applications.



Ambient Light Sensor

Vishay enables electronic products like LCD displays and streetlights to sense and respond to light in ways similar to the human eye. The TEMT6000X01, TEMT6200FX01, TEPT4400, TEPT5600 and TEPT5700 are small phototransistors with peak sensitivity of 570 nm. With a unique, patent-pending filtering material, interference from infrared and ultraviolet light is virtually eliminated. The TEMD5510FX01 and TEMD6010FX01 photodiodes are qualified to the automotive's most rigorous standard, AEC Q101.



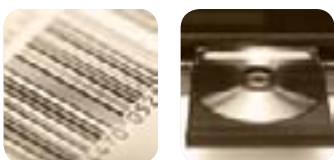
Lead (Pb)-Free and RoHS

All products listed are lead (Pb)-free and comply with RoHS 2002/95/EC and WEEE 2002/96/EC. Each datasheet provides a recommended solder profile for processing and the JEDEC level for moisture sensitivity.



Samples

If you need samples, they will be shipped at no charge to you within 24 hours of order entry. To order, visit our web site for the nearest sales representative or distributor in your area.



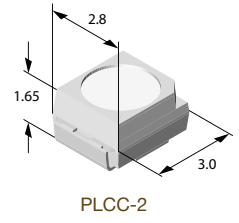
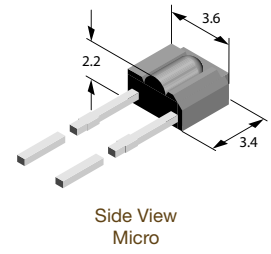
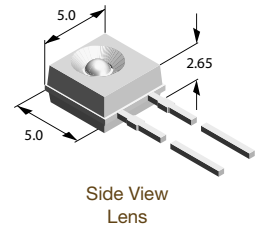
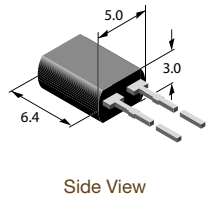
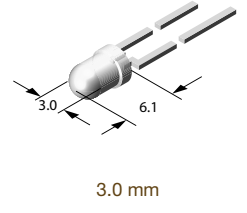
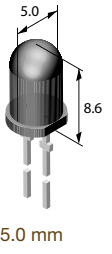
NOTICE Specifications of the products displayed herein are subject to change without notice. Vishay Intertechnology, Inc., or anyone on its behalf, assumes no responsibility or liability for any errors or inaccuracies. Information contained herein is intended to provide a product description only. No license, express or implied, by estoppel or otherwise, to any intellectual property rights is granted by this document. Except as provided in Vishay's terms and conditions of sale for such products, Vishay assumes no liability whatsoever, and disclaims any express or implied warranty, relating to sale and/or use of Vishay products including liability or warranties relating to fitness for a particular purpose, merchantability, or infringement of any patent, copyright, or other intellectual property right. The products shown herein are not designed for use in medical, life-saving, or life-sustaining applications. Customers using or selling these products for use in such applications do so at their own risk and agree to fully indemnify Vishay for any damages resulting from such improper use or sale.



Infrared Emitters



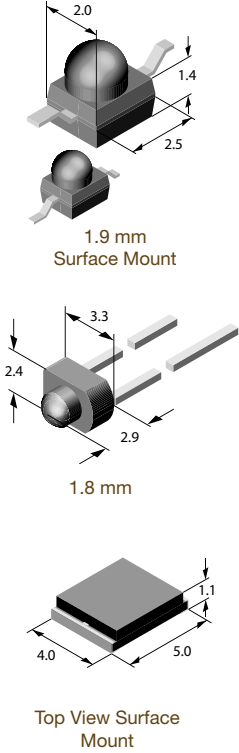
Package	Part Number	Peak Wavelength (nm)	Angle of Half Intensity (+/-°)	Radiant Intensity, I _e (mW/sr) ⁽¹⁾	Rise and Fall Time, t _r /t _f (ns) ⁽¹⁾
Infrared Emitters					
5.0 mm	TSAL5100	940	10	130	800
	TSAL5300	940	22	45	800
	TSAL6100	940	10	130	800
	TSAL6200	940	17	60	800
	TSAL6400	940	25	40	800
	TSAL7200	940	17	60	800
	TSAL7300	940	22	45	800
	TSAL7400	940	25	40	800
	TSAL7600	940	30	25	800
	TSFF5210	870	10	180	15
	TSFF5410	870	22	70	15
	TSHF5210	870	10	160	30
	TSHF5410	870	22	70	30
	TSHA5203	875	12	65	600
	TSHA5503	875	24	35	600
	TSHA6203	875	12	65	600
	TSHA6503	875	24	35	600
	TSHG6200	850	10	160	20
	TSHG6400	850	22	70	20
	TSHG8200	830	10	160	20
TSHG8400	830	20	79	20	
TSUS5202	950	15	30	800	
TSUS5402	950	22	20	800	
1.9 mm, Surface Mount	TSML1000/1020	950	12	7 ⁽²⁾	800
	TSMF1000/1020	870	17	5 ⁽²⁾	30
3.0 mm	TSUS4300	950	16	18	800
	TSUS4400	950	18	15	800
	TSAL4400	940	25	30	800
	TSHA4400	875	20	20	600
1.8 mm	CQY37N	950	12	5	800
	CQY36N	950	55	1.5	800
Side View Micro	TSSS2600	950	25H, 65V ⁽³⁾	2.6	800
Side View Lens	TSKS5400S	950	30	9	800
TO-18	TSTS7100	950	5	18	800
	TSTS7300	950	12	6	800
	TSTS7500	950	30	1.6	800
	TSTA7100	875	5	50	600
	TSTA7300	875	12	20	600
	TSTA7500	875	30	6	600
PLCC-2, Surface Mount	VSMF3710	870	60	10	30
	VSMF4710	870	60	10	15
	VSMG2700	830	60	10	15
	VSMG3700	850	60	10	20
	VSML3710	950	60	8	800
	VSMS3700	950	60	4.5	800



Notes: 1) I_t = 100 mA 2) I_t = 20 mA 3) Horizontal and vertical

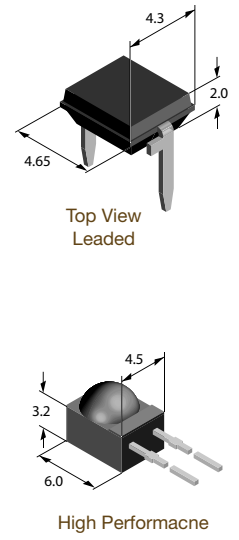


Photo Detectors



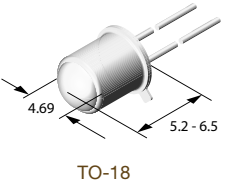
Package	Part Number	Peak Wavelength (nm)	Bandwidth, $\lambda_{0.5}$ (nm)	Sensitivity, I_{ra} (μA) ⁽¹⁾	Angle of Half Sensitivity (+/-°)	Photo Area (mm ²)	Rise and Fall Time, t_r/t_f (ns) ⁽²⁾
PIN Photodiodes							
5.0 mm	BPV10	920	570 to 1040	70	20	0.78	2.5 ⁽³⁾
	BPV10NF	940	790 to 1050	60	20	0.78	2.5 ⁽³⁾
1.9 mm, SMD	TEMD1000/1020	900	840 to 1050	10	15	0.25	4 ⁽⁴⁾
	BPV20F	950	870 to 1050	60	65	7.5	100
Side View	BPV21F(L)	950	870 to 1050	38	65	5.7	70
	BPW41N	950	870 to 1050	45	65	7.5	100
	BPW46, L	900	600 to 1050	50	65	7.5	100
	BPW82, 83	950	790 to 1050	45	65	7.5	100
	S186P	950	870 to 1050	45	65	7.5	100
	High Performance	BPV22F	950	870 to 1050	80	60	7.5
BPV22NF		940	790 to 1050	85	60	7.5	100
BPV23F		950	870 to 1050	63	60	5.7	70
BPV23NF		940	790 to 1050	65	60	5.7	70
TO-18	TESP5700	870	790 to 980	25	60	2	10
	BPW24R	900	600 to 1050	60	12	0.78	7 ⁽⁴⁾⁽⁵⁾
Top View, Leaded	BPW34	900	600 to 1050	50	65	7.5	100
	BP104	950	870 to 1050	45	65	7.5	100
Top View, SMD	TEMD5010X01	900	400 to 1100	55	65	7.5	100
	TEMD5020X01	900	400 to 1100	35	65	4.4	100
	TEMD5110X01	940	790 to 950	55	65	7.5	100
	TEMD5120X01	940	790 to 950	35	65	4.4	100

Notes: (1) Sensitivity: $V_R = 5$ V, $E_e = 1$ mW/cm², $\lambda = 950$ nm (2) Speed: $R_L = 1$ k Ω , $\lambda = 820$ nm, $V_R = 10$ V
 (3) $V_R = 50$ V, $R_L = 50$ Ω , $\lambda = 820$ nm (4) $R_L = 50$ Ω (5) $V_R = 20$ V



Package	Part Number	Peak Wavelength (nm)	Bandwidth, $\lambda_{0.5}$ (nm)	Collector Light Current, I_{ca} (mA) ⁽¹⁾	Angle of Half Sensitivity (+/-°)	Rise and Fall Time, t_r/t_f (μs) ⁽²⁾
Phototransistors						
5.0 mm	BPV11	850	620 to 980	10	15	6
	BPV11F	930	900 to 980	9	15	6
	BPW96C	850	620 to 980	8	20	2
3.0 mm	BPW85C	850	620 to 980	5	25	2
	TEFT4300	925	875 to 1000	3.2	30	2
1.8 mm	BPW16N	825	620 to 960	0.14	40	4.8
	BPW17N	825	620 to 960	1	12	4.8
Side View Micro	TEST2600	920	850 to 980	2.5	30 H 60 V	6
Side View Lens	TEKT5400S	920	850 to 980	4	37	6
TO-18	BPW76B	850	620 to 980	1.2	40	6
	BPW77NB	850	620 to 980	20	10	6
1.9 mm, SMD	TEMT1000/1020	950	750 to 980	7	15	2
	PLCC-2, SMD	VEMT3700	830	620 to 980	0.5	60
VEMT3700F		940	860 to 1050	0.5	60	2
VEMT4700		830	620 to 980	0.5	60	2

Notes: (1) Collector light current: $V_{CE} = 5$ V, $E_e = 1$ mW/cm², $\lambda = 950$ nm, typical (2) Speed: $R_L = 0.1$ k Ω , $\lambda = 950$ nm, $V = 5$ V, $V_C = 5$ mA



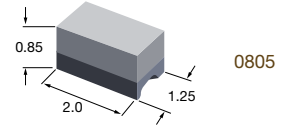
Package	Part Number	Peak Wavelength (nm)	Bandwidth, $\lambda_{0.5}$ (nm)	Supply Current (mA)	Angle of Half Sensitivity (+/-°)	Hysteresis	On / Off Time t_{on}/t_{off} (μs)
Photo Schmitt Trigger							
Side View Lens	TEKS5400	920	825 to 950	2	30	80 %	1.5 / 3.0
	TEKS6400	920	825 to 950	0.045	30	80 %	1.5 / 3.0



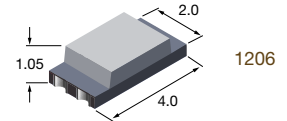
Optical Sensors



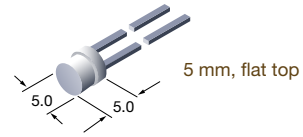
Package	Part Number	Peak Wavelength (nm)	Bandwidth (nm)	Angle of Half Sensitivity (+/-°)	Light Current ⁽¹⁾ Incandescent Light (µA)	Light Current ⁽²⁾ Fluorescent Light (µA)
Ambient Light Sensor - Photodiodes						
1206 SMD	TEMD6010FX01	540	430 - 610	60	0.04	0.03
Top View, SMD	TEMD5510FX01	540	430 - 610	65	1.00	0.70
Ambient Light Sensor - Phototransistors						
0805 SMD	TEMT6200FX01	550	450 - 610	60	23	14
1206 SMD	TEMT6000X01	570	430 - 800	60	50	21
5 mm, flat top	TEPT5700	570	430 - 800	50	75	31
5 mm	TEPT5600	570	430 - 800	20	350	145
3 mm	TEPT4400	570	430 - 800	30	200	83



0805



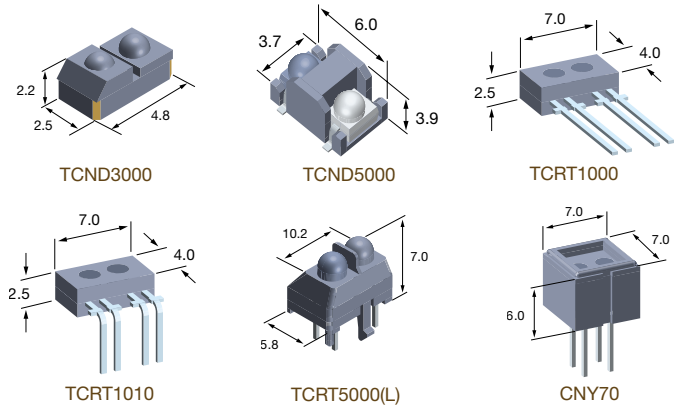
1206



5 mm, flat top

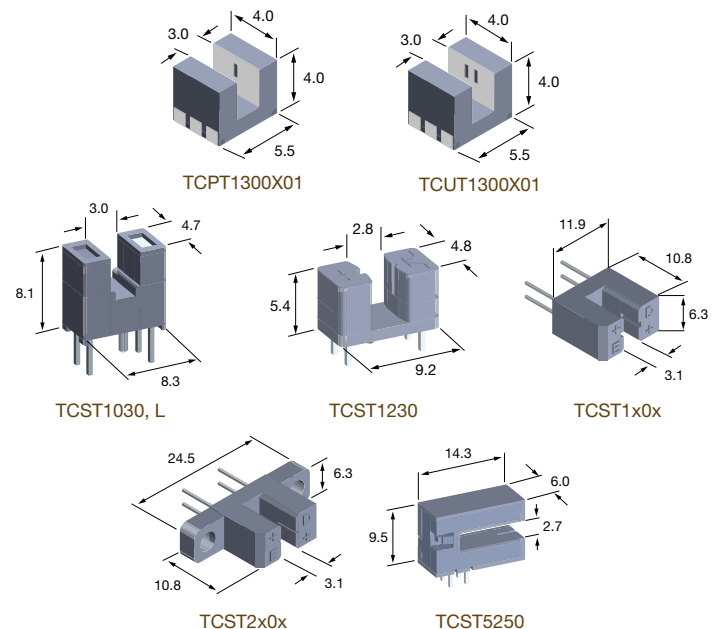
Notes: (1) $E_v=100$ lux, $V_{CE} = 5$ V, CIE illuminant A, typical
 (2) $E_v=100$ lux, $V_{CE} = 5$ V, e.g. Sylvania color abbrev. D830, typical

Part Number	Operating Range ⁽²⁾ (mm)	Peak Operating Distance (mm)
Reflective Sensors⁽¹⁾		
TCND3000 ⁽³⁾	1 to 20	0 and 10
TCND5000 ⁽⁴⁾	2 to 25	7
TCRT1000/1010	1 to 2	1
TCRT5000(L)	1 to 14	2.5
CNY70	1 to 3	0



Notes: (1) All optical sensors have phototransistor output except where noted
 (2) Relative collector current > 20%
 (3) TCND3000 operates only with E909.01 ELMOS ASIC
 (4) TCND5000 has a PIN photodiode output

Part Number	Gap (mm)	Aperture (mm)	On / Off Time t_{on}/t_{off} (µs)
Transmissive or Interrupter Sensors⁽¹⁾			
TCPT1300X01	3.0	0.3	20 / 30
TCUT1300X01 ⁽²⁾	3.0	0.3	20 / 30
TCST1030, L	3.0	none	15 / 10
TCST1103	3.2	1	10 / 8
TCST1202	3.2	0.5	10 / 8
TCST1230	3.0	0.5	15 / 10
TCST1300	3.2	0.25	10 / 8
TCST2103	3.2	1	10 / 8
TCST2202	3.2	0.5	10 / 8
TCST2300	3.2	0.25	10 / 8
TCST5250	2.7	0.5	15 / 10



Notes: (1) All optical sensors have phototransistor output
 (2) Dual channel



SEMICONDUCTORS:

Rectifiers • High-Power Diodes and Thyristors • Small-Signal Diodes • Zener and Suppressor Diodes
• FETs • RF Transistors • Optoelectronics • ICs • Modules and Assemblies

PASSIVE COMPONENTS:

Resistive Products • Magnetics • Capacitors • Strain Gage Transducers and Stress Analysis Systems

**One of the World's Largest
Manufacturers**
of Discrete Semiconductors and Passive Components

WORLDWIDE SALES CONTACTS

THE AMERICAS

UNITED STATES

VISHAY AMERICAS
ONE GREENWICH PLACE
SHELTON, CT 06484
UNITED STATES
PH: +1-402-563-6866
FAX: +1-402-563-6296

ASIA

SINGAPORE

VISHAY INTERTECHNOLOGY
ASIA PTE LTD.
25 TAMPINES STREET 92
KEPPEL BUILDING #02-00
SINGAPORE 528877
PH: +65-6788-6668
FAX: +65-6788-0988

P.R. CHINA

VISHAY TRADING (SHANGHAI) CO., LTD.
15D, SUN TONG INFOPORT PLAZA
55 HUAI HAI WEST ROAD
SHANGHAI 200030
P.R. CHINA
PH: +86-21-5258 5000
FAX: +86-21-5258 7979

JAPAN

VISHAY JAPAN CO., LTD.
MG IKENOHATA BLDG. 4F
1-2-18, IKENOHATA
TAITO-KU
TOKYO 110-0008
JAPAN
PH: +81-3-5832-6210
FAX: +81-3-5832-6260

EUROPE

GERMANY

VISHAY EUROPE SALES GMBH
GEHEIMRAT-ROSENTHAL-STR. 100
95100 SELB
GERMANY
PH: +49-9287-71-0
FAX: +49-9287-70435

FRANCE

VISHAY S.A.
199, BLVD DE LA MADELEINE
06003 NICE, CEDEX 1
FRANCE
PH: +33-4-9337-2920
FAX: +33-4-9337-2997

UNITED KINGDOM

VISHAY LTD.
PALLION INDUSTRIAL ESTATE
SUNDERLAND SR4 6SU
UNITED KINGDOM
PH: +44-191-514-4155
FAX: +44-191-567-8262