

# CA124, CA224, CA324, LM324, LM2902

## Quad, 1MHz, Operational Amplifiers for Commercial, Industrial, and Military Applications

November 1996

### Features

- Operation from Single or Dual Supplies
- Unity-Gain Bandwidth ..... 1MHz (Typ)
- DC Voltage Gain ..... 100dB (Typ)
- Input Bias Current ..... 45nA (Typ)
- Input Offset Voltage ..... 2mV (Typ)
- Input Offset Current
  - CA224, CA324, LM324, LM2902 ..... 5nA (Typ)
  - CA124 ..... 3nA (Typ)
- Replacement for Industry Types 124, 224, 324

### Applications

- Summing Amplifiers
- Multivibrators
- Oscillators
- Transducer Amplifiers
- DC Gain Blocks

### Description

The CA124, CA224, CA324, LM324, and LM2902 consist of four independent, high-gain operational amplifiers on a single monolithic substrate. An on-chip capacitor in each of the amplifiers provides frequency compensation for unity gain. These devices are designed specially to operate from either single or dual supplies, and the differential voltage range is equal to the power-supply voltage. Low power drain and an input common-mode voltage range from 0V to V+ -1.5V (single-supply operation) make these devices suitable for battery operation.

### Ordering Information

PART NUMBER (BRAND)	TEMP. RANGE (°C)	PACKAGE	PKG. NO.
CA0124E	-55 to 125	14 Ld PDIP	E14.3
CA0124M (124)	-55 to 125	14 Ld SOIC	M14.15
CA0124M96 (124)	-55 to 125	14 Ld SOIC Tape and Reel	M14.15
CA0224E	-40 to 85	14 Ld PDIP	E14.3
CA0224M (224)	-40 to 85	14 Ld SOIC	M14.15
CA0224M96 (224)	-40 to 85	14 Ld SOIC Tape and Reel	M14.15
CA0324E	0 to 70	14 Ld PDIP	E14.3
CA0324M (324)	0 to 70	14 Ld SOIC	M14.15
CA0324M96 (324)	0 to 70	14 Ld SOIC Tape and Reel	M14.15
LM324N	0 to 70	14 Ld PDIP	E14.3
LM2902N	-40 to 85	14 Ld PDIP	E14.3
LM2902M (2902)	-40 to 85	14 Ld SOIC	M14.15
LM2902M96 (2902)	-40 to 85	14 Ld SOIC Tape and Reel	M14.15

### Pinout

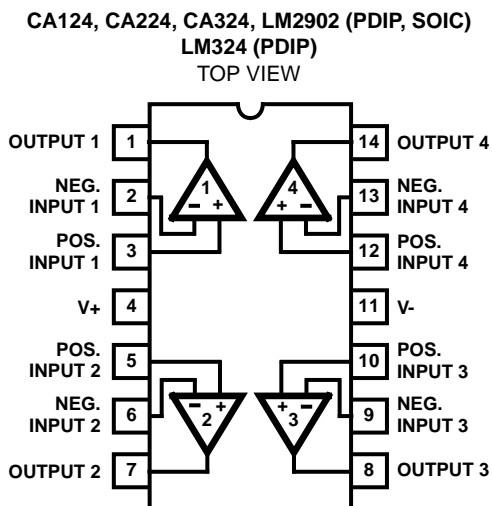

# CA124, CA224, CA324, LM324, LM2902

## Absolute Maximum Ratings

Supply Voltage .....	32V or $\pm 16V$
Differential Input Voltage.....	32V
Input Voltage.....	-0.3V to 32V
Input Current ( $V_I < -0.3V$ , Note 1).....	50mA
Output Short Circuit Duration ( $V+ \leq 15V$ , Note 2).....	Continuous

## Operating Conditions

Temperature Range	
CA124.....	-55°C to 125°C
CA224, LM2902 .....	-40°C to 85°C
CA324, LM324 .....	0°C to 70°C

## Thermal Information

Thermal Resistance (Typical, Note 3)	$\theta_{JA}$ (°C/W)
PDIP Package .....	100
SOIC Package.....	175
Maximum Junction Temperature (Die) .....	175°C
Maximum Junction Temperature (Plastic Package) .....	150°C
Maximum Storage Temperature Range .....	-65°C to 150°C
Maximum Lead Temperature (Soldering 10s).....	300°C
(SOIC - Lead Tips Only)	

**CAUTION:** Stresses above those listed in "Absolute Maximum Ratings" may cause permanent damage to the device. This is a stress only rating and operation of the device at these or any other conditions above those indicated in the operational sections of this specification is not implied

## NOTES:

1. This input current will only exist when the voltage at any of the input leads is driven negative. This current is due to the collector base junction of the input p-n-p transistors becoming forward biased and thereby acting as input diode clamps. In addition to this diode action, there is also lateral n-p-n parasitic transistor action on the IC chip. This transistor action can cause the output voltages of the amplifiers to go to the  $V+$  voltage level (or to ground for a large overdrive) for the time duration that an input is driven negative. This transistor action is not destructive and normal output states will re-establish when the input voltage, which was negative, again returns to a value greater than -0.3V.
2. The maximum output current is approximately 40mA independent of the magnitude of  $V+$ . Continuous short circuits at  $V+ > 15V$  can cause excessive power dissipation and eventual destruction. Short circuits from the output to  $V+$  can cause overheating and eventual destruction of the device.
3.  $\theta_{JA}$  is measured with the component mounted on an evaluation PC board in free air.

## Electrical Specifications

Values Apply for Each Operational Amplifier. Supply Voltage  $V+ = 5V$ ,  $V- = 0V$ , Unless Otherwise Specified

PARAMETER	TEST CONDITIONS	TEMP. (°C)	CA124			CA224, CA324, LM324			LM2902			UNITS
			MIN	TYP	MAX	MIN	TYP	MAX	MIN	TYP	MAX	
Input Offset Voltage (Note 6)		25	-	2	5	-	2	7	-	-	-	mV
		Full	-	-	7	-	-	9	-	-	10	mV
Average Input Offset Voltage Drift	$R_S = 0\Omega$	Full	-	7	-	-	7	-	-	7	-	$\mu V/^\circ C$
Differential Input Voltage (Note 5)		Full	-	-	$V+$	-	-	$V+$	-	-	$V+$	V
Input Common Mode Voltage Range (Note 5)	$V+ = 30V$	25	0	-	$V+ - 1.5$	0	-	$V+ - 1.5$	-	-	-	V
	$V+ = 30V$	Full	0	-	$V+ - 2$	0	-	$V+ - 2$	-	-	-	V
	$V+ = 26V$	Full	-	-	-	-	-	-	0	-	$V+ - 2$	V
Common Mode Rejection Ratio	DC	25	70	85	-	65	70	-	-	-	-	dB
Power Supply Rejection Ratio	DC	25	65	100	-	65	100	-	-	-	-	dB
Input Bias Current (Note 4)	$I_{I+}$ or $I_{I-}$	25	-	45	150	-	45	250	-	-	-	nA
	$I_{I+}$ or $I_{I-}$	Full	-	-	300	-	-	500	-	40	500	nA
Input Offset Current	$I_{I+} - I_{I-}$	25	-	3	30	-	5	50	-	-	-	nA
	$I_{I+} - I_{I-}$	Full	-	-	100	-	-	150	-	45	200	nA
Average Input Offset Current Drift		Full	-	10	-	-	10	-	-	10	-	$pA/^\circ C$

## CA124, CA224, CA324, LM324, LM2902

**Electrical Specifications** Values Apply for Each Operational Amplifier. Supply Voltage  $V_+ = 5V$ ,  $V_- = 0V$ , Unless Otherwise Specified **(Continued)**

PARAMETER	TEST CONDITIONS	TEMP. (°C)	CA124			CA224, CA324, LM324			LM2902			UNITS	
			MIN	TYP	MAX	MIN	TYP	MAX	MIN	TYP	MAX		
Large Signal Voltage Gain	$R_L \geq 2k\Omega$ , $V_+ = 15V$ (For Large $V_O$ Swing)	25	94	100	-	88	100	-	-	-	-	dB	
	$R_L \geq 2k\Omega$ , $V_+ = 15V$ (For Large $V_O$ Swing)	Full	88	-	-	83	-	-	83	-	-	dB	
Output Voltage Swing	$R_L = 2k\Omega$	25	0	-	$V_+ - 1.5$	0	-	$V_+ - 1.5$	-	-	-	V	
	High Level	$R_L = 2k\Omega$ , $V_+ = 30V$	Full	26	-	-	26	-	-	-	-	V	
		$R_L = 2k\Omega$ , $V_+ = 26V$	Full	-	-	-	-	-	-	22	-	-	V
		$R_L = 10k\Omega$ , $V_+ = 30V$	Full	27	28	-	27	28	-	23	28	-	V
	Low Level	$R_L = 10k\Omega$	Full	-	5	20	-	5	20	-	5	100	mV
Output Current	Source	$V_{I+} = +1V$ , $V_{I-} = 0V$ , $V_+ = 15V$	25	20	40	-	20	40	-	-	-	-	mA
		$V_{I+} = 1V$ , $V_{I-} = 0$ , $V_+ = 15V$	Full	10	20	-	10	20	-	10	20	-	mA
	Sink	$V_{I+} = 0V$ , $V_{I-} = 1V$ , $V_+ = 15V$	25	10	20	-	10	20	-	-	-	-	mA
		$V_{I+} = 0V$ , $V_{I-} = 1V$ , $V_O = 200mV$	25	12	50	-	12	50	-	-	-	-	$\mu A$
		$V_{I-} = 1V$ , $V_{I+} = 0$ , $V_+ = 15V$	Full	5	8	-	5	8	-	5	8	-	mA
Crosstalk	$f = 1$ to $20kHz$ (Input Referred)	25	-	-120	-	-	-120	-	-	-	-	dB	
Total Supply Current	$R_L = \infty$	Full	-	0.8	2	-	0.8	2	-	0.7	1.2	mA	
	$R_L = \infty$ , $V_+ = 26V$	Full	-	-	-	-	-	-	-	1.5	3	mA	

**NOTES:**

4. Due to the PNP input stage the direction of the input current is out of the IC. No loading change exists on the input lines because the current is essentially constant, independent of the state of the output.
5. The input signal voltage and the input common mode voltage should not be allowed to go negative by more than 0.3V. The positive limit of the common mode voltage range is  $V_+ - 1.5V$ , but either or both inputs can go to +32V without damage.
6.  $V_O = 1.4V$ ,  $R_S = 0\Omega$  with  $V_+$  from 5V to 30V, and over the full input common mode voltage range (0V to  $V_+ - 1.5V$ ).

**Schematic Diagram** (One of Four Operational Amplifiers)

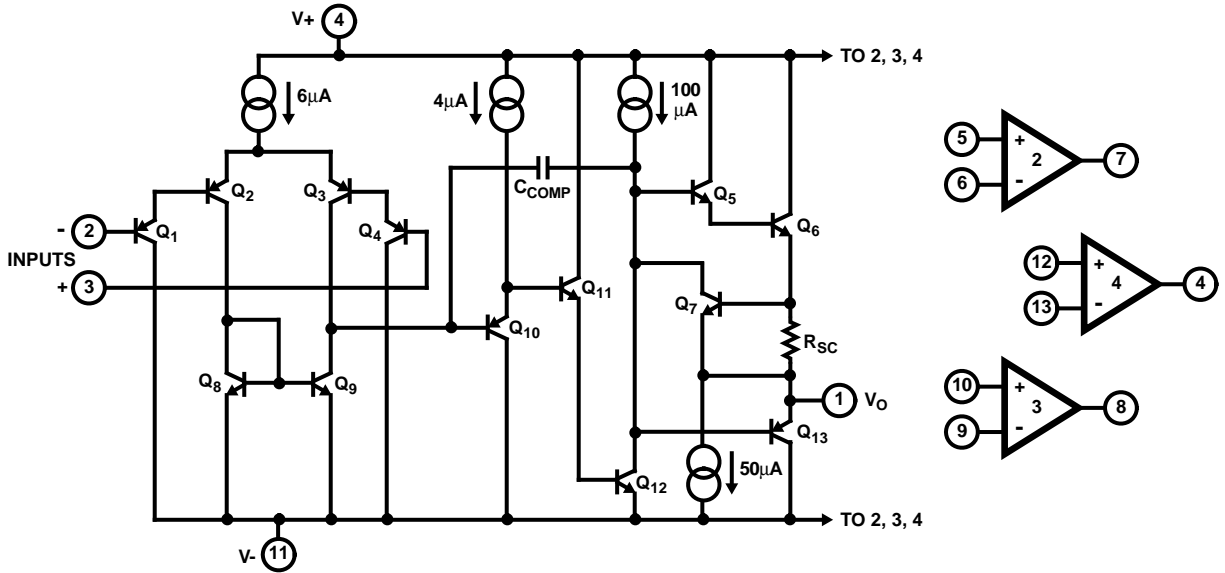

**Typical Performance Curves**

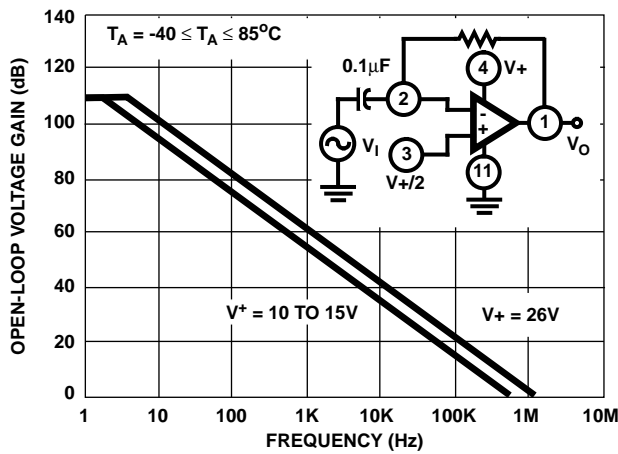

FIGURE 1. OPEN LOOP FREQUENCY RESPONSE

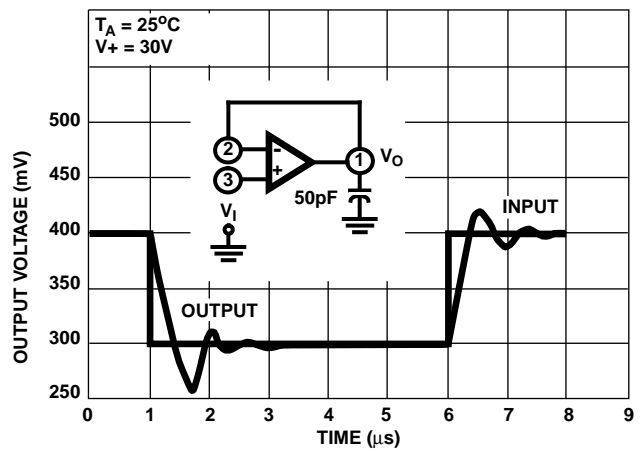

FIGURE 2. VOLTAGE FOLLOWER PULSE RESPONSE (SMALL SIGNAL)

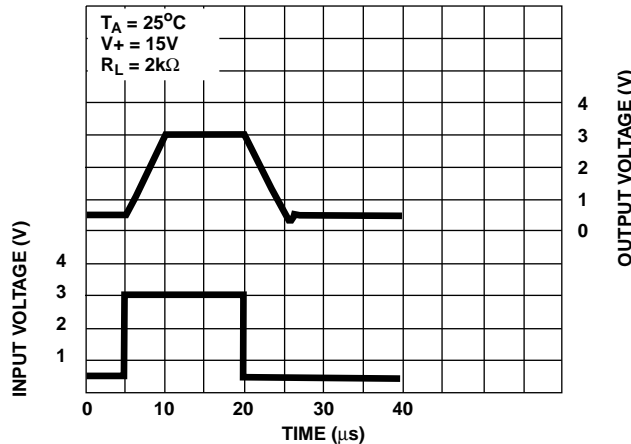

FIGURE 3. VOLTAGE FOLLOWER PULSE RESPONSE (LARGE SIGNAL)

Typical Performance Curves (Continued)

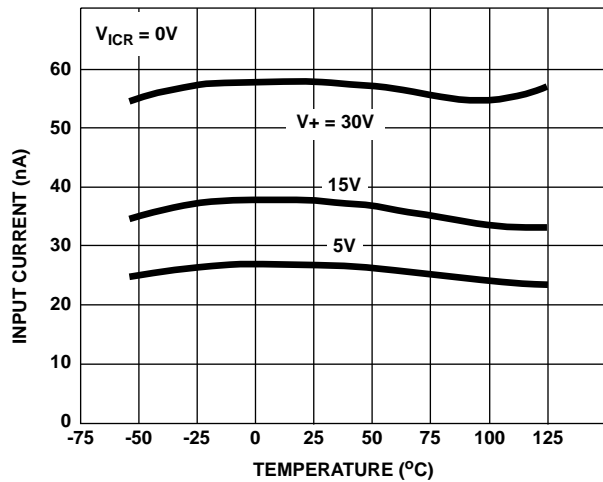

FIGURE 4. INPUT CURRENT vs AMBIENT TEMPERATURE

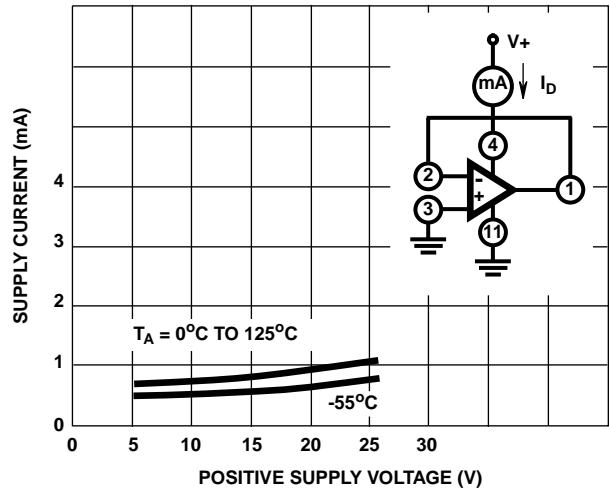

FIGURE 5. SUPPLY CURRENT vs SUPPLY VOLTAGE

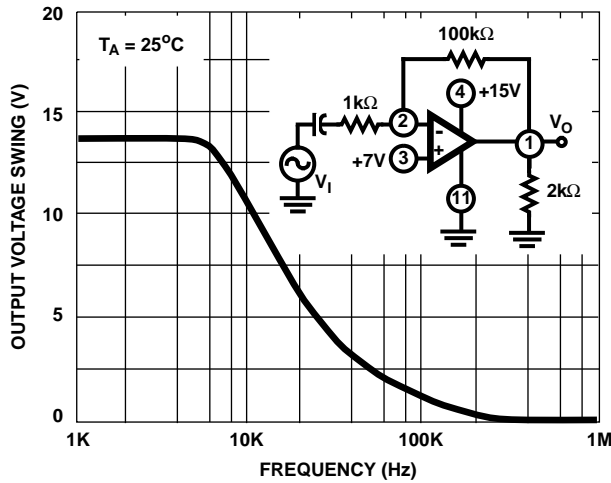

FIGURE 6. LARGE SIGNAL FREQUENCY RESPONSE

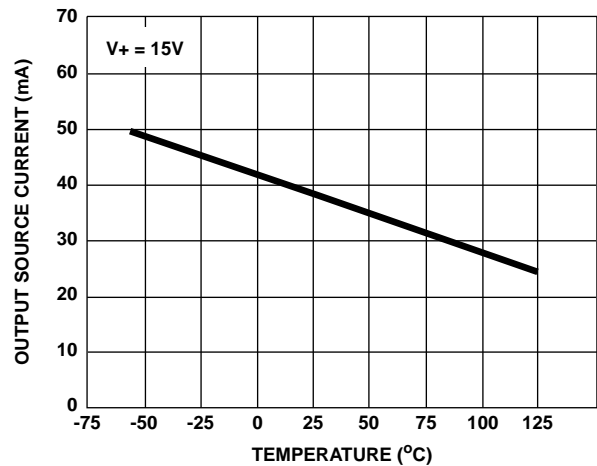

FIGURE 7. OUTPUT CURRENT vs AMBIENT TEMPERATURE

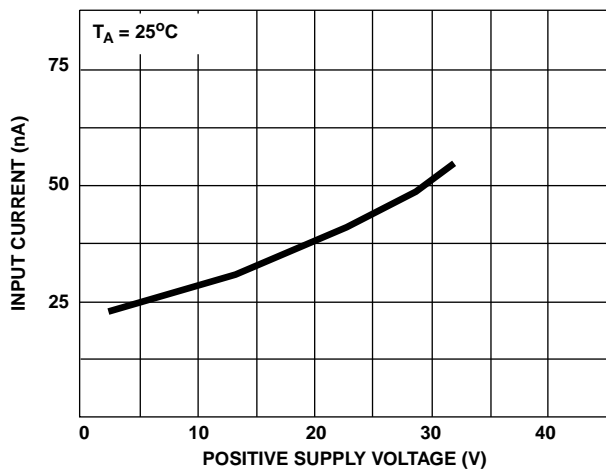

FIGURE 8. INPUT CURRENT vs SUPPLY VOLTAGE

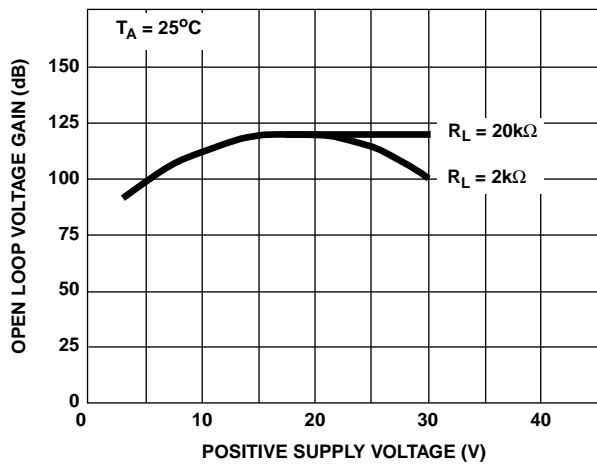

FIGURE 9. VOLTAGE GAIN vs SUPPLY VOLTAGE