

# Instruction Manual For SVPT115 / SVPQ130 AC/DC Power Supply

**SVPT115 SERIES  
SVPQ130 SERIES**

**FEATURES:**

- Universal 85-265 VAC Input
- Short Circuit Protection
- VDE/FCC Level "B" Input Filter
- VDE,CSA,UL & IEC Safety Specs
- Compact 4.75" x 1.77" x 8.5"
- Optional Cover & PCB Only Available
- Optional Input and Output Good Signals (1)
- Optional 110/220 Vac Jumper Select
- Remote Sense of main output

**DESCRIPTION:**

The SVPT/SVPQ 115/130 Series is a multiple output, high performance line of quad and triple output power supplies in an open frame chassis. The SV (Superior Value) series gives the system designer tremendous flexibility with its standard features and available options. Standard features include automatic AC mains select, Class "B" VDE and FCC EMI filtering, Remote Voltage Sensing on the +5 volt main output and Short Circuit Protection on each output. Optional features include a Safety Cover, Input Good, Output Good, PC Board only and jumper AC mains select.

**MODEL NUMBERS & MAXIMUM RATINGS**

SPECIFICATION	CONFIGURATION	MODEL NUMBER		
		SVPQ130-1-XXX	SVPQ130-2-XXX	SVPT115-1-XXX
Package Power	Without Cover	130 Watts	130 Watts	115 Watts
50°C Ambient	PCB Only (-N option)	117 Watts	117 Watts	104 Watts
125 LFM External Fan	With Cover (-Z Option)	117 Watts	117 Watts	104 Watts
Package Power	Without Cover	111 Watts	111 Watts	98 Watts
60°C Ambient	PCB Only (-N option)	100 Watts	100 Watts	88 Watts
125 LFM External Fan	With Cover (-Z Option)	100 Watts	100 Watts	88 Watts
Package Power	Without Cover	100 Watts	100 Watts	100 Watts
50°C Ambient	PCB Only (-N option)	80 Watts	80 Watts	80 Watts
Convection Cooling	With Cover (-Z Option)	90 Watts	90 Watts	90 Watts
Package Power	Without Cover	85 Watts	85 Watts	85 Watts
60°C Ambient	PCB Only (-N option)	70 Watts	70 Watts	70 Watts
Convection Cooling	With Cover (-Z Option)	77 Watts	77 Watts	77 Watts

**INPUT SPECIFICATIONS**

SPECIFICATION	CONDITIONS	MIN	NOM	MAX	UNITS
Input Voltage +/- 0%	AC Range Low	85	115	132	VAC
	AC Range High	180	230	265	VAC
Input Current	Vin=85 Vac @130W			3.8	Arms
Efficiency			70%		%
Input Power Typical (Pout Max, Fan Cooled)	Vin=85 Vac @130W		186		Watts
Inrush Current	Vin=264 Vac @ 25°C			75	Apeak
Fusing	5A/250VAC, Normal Blo (2)				

Harmonics - Meets IEC 555-2 AC line harmonics requirement.

- (1) DC good signal is a 1mA conductance signal which indicates that DC output voltage is greater than 90% of nominal voltage. AC good signal is a 1mA conductance signal indicating adequate input cap energy storage to meet hold up specification. DC output voltage will remain within regulation limits for a minimum of 10mS after AC good signal ceases to conduct. AC good signal is initiated approximately 2 seconds after input power is applied.
- (2) Overload of power supply does not cause fuse failure. Replace only with same type and rating.

**MECHANICAL SPECIFICATIONS  
(STANDARD MODEL)**

SPECIFICATION	
Weight	3lbs
Input	.156" center

**OPTIONS SPECIFICATIONS**

-XXX	DESCRIPTION	DERATING
N	PC Board only construction.	10% for fan cooled
	All output currents must be derated by:	20% for convection cooled

Connector	Molex Mating P/N 09-50-8051
Output and Signals Connector	.156" center Molex Mating P/N 09-50-8180
Mounting	2 Mounting Positions
See Outline Drawing	2 Mounting Surfaces

A	Jumper Select 110/220 Vac input	
Z	Fully Enclosed Unit.	10% for fan cooled
	All output currents must be derated by:	10% for convection cooled
L	No Monitoring Signals	

Note: See Figure 5 for -N option. Grounding must be provided by customer as shown.

**MAIN OUTPUT- V1 SPECIFICATIONS (STANDARD MODELS)**

SPECIFICATION	CONDITIONS	MIN	NOM	MAX	UNITS
Output Voltage (Adjustable)		4.75	5	5.25	V
Output Current (Power)	@ 50°C Ambient			15.0 (75)	A (Watts)
Output Current (Power)	@ 60°C Ambient			12.8 (64)	A (Watts)
Output Ripple				100	mV pk-pk
Total Regulation - Line and Load	Over Input Line Range			50	mV
	3.8 to 15 A				
Pre-Load Requirements(3)		3.8			A
Over Voltage Protection	Trip Levels	6		6.9	V
Turn-on Time	85Vac			2	SEC
Overshoot	Turn On, Turn Off, or Power Failure			0	V
Hold-up Time	@ 85 Vac	16			mSEC
Remote Sense (4)	Max Cable Drop			0.5	V

**OUTPUT- V2 SPECIFICATIONS (STANDARD MODELS)**

SPECIFICATION	CONDITIONS	MIN	NOM	MAX	UNITS
Output Voltage (fixed)	Factory Set (5)	11.9	12	12.1	V
Output Current (Power)	@ 50°C Ambient			2.5 (30)	A (Watts)
Output Current (Power)	@ 60°C Ambient			2.1 (26)	A (Watts)
Output Ripple				240	mV pk-pk
Pre-Load Requirements	3.8 A on V1				A
Total Regulation - Line and Load	Over Input Line Range			600	mV
	50% Load Change				
Overshoot	Turn On, Turn Off, or Power Failure			0	V
Peak Output Current	See note (6)		7.5		A

**OUTPUT- V3 SPECIFICATIONS (STANDARD MODELS)**

SPECIFICATION	CONDITIONS	MIN	NOM	MAX	UNITS
Output Voltage (fixed)	Factory Set (5)	-11.4	-12	-12.6	V
Output Current (Power)	@ 50°C Ambient	0.2		1.0 (12)	A (Watts)
Output Current (Power)	@ 60°C Ambient	0.2		0.9 (10)	A (Watts)
Output Ripple				240	mV pk-pk
Pre-Load Requirements	3.8 A on V1, 0.2 A on V3				A
Total Regulation - Line and Load	Input Line Range, 0.2 - 1A Load			600	mV
	50% Load Change, 0.2 - 1A Load				
Overshoot	Turn On, Turn Off, or Power Failure			0	V
Peak Output Current	See note (6)		3		A

(3) 3.8 Amps required on V1 for proper regulation of auxiliaries.

(4) Remote sensing on the main output is accomplished by removing JP2 and JP3 from the printed circuit board and connecting the load to the +S1 and -S1 terminals found on J2. The maximum cable drop is 0.5 volts.

(5) Minimum load on V1 and no load on auxiliaries.

(6) Peak output current lasting less than 30 seconds with a duty cycle of < 5%. During peak current transients the outputs may not meet regulation specifications. Multiple outputs delivering peak currents may cause the power supply to current limit.

**OUTPUT- V4 SPECIFICATIONS (STANDARD SVPQ130-1 and SVPQ130-2 MODELS)**

SPECIFICATION	CONDITIONS	MIN	NOM	MAX	UNITS
Output Voltage (-1)	Factory Set	22.8	24	25.2	V
Output Voltage (-2)	Factory Set	-4.75	-5	-5.25	V
Output Current (Power) (-1)	@ 50°C Ambient			0.8 (19)	A (Watts)
Output Current (Power) (-2) (7)	@ 50°C Ambient			1.5 (7.5)	A (Watts)
Output Current (Power) (-1)	@ 60°C Ambient			0.7 (16)	A (Watts)
Output Current (Power) (-2) (7)	@ 60°C Ambient			1.3(6.8)	A (Watts)
Output Ripple (-1)				480	mV pk-pk
Output Ripple (-2)				100	mV pk-pk

Total Regulation - Line and Load	Over Input Line Range			1200	mV
	50% Load Change				
Total Regulation - Line and Load	Over Input Line Range			250	mV
	50% Load Change				
Pre-Load Requirements	3.8 A on V1				A
Overshoot	Turn On, Turn Off, or Power Failure			0	V

(7) With fan cooling of 200 LFM, the maximum output current increases to 2.0 and 1.7 amps respectively.

(8) Unit meets drop test in the Lambda shipping container.

**GENERAL SPECIFICATIONS**

**(STANDARD MODEL)**

SPECIFICATION	CONDITIONS	
Isolation Voltages	Input to Output	3000 Vac
	Input to Signals	3000 Vac
	Input to Chassis	1500 Vac
	Output to Chassis	500 Vac
	Output to Signals	500 Vac
Leakage Current		1 mA Max
Agency Approvals	UL1950, CSA22.2 #234-M90, EN60950, IEC950, EN410003	
Input Surge Protection	IEC801-2,-4,-5 Level 3 IEEE C62.41-1991 Location Cat. A2 (A3 w/ ext. MOV's)	
EMI Conducted	VDE0871 Curve B, FCC Part 15 Subpart J Class B	

**TERMINAL CONNECTIONS**

J2	DC OUTPUT
1	N/C
2	-V4
3	+V4
4	AC Good return
5	AC Good
6	-V3
7	+V2
8	+S
9	-S
10	Common(-V1,-V2,+V3)
11	Common(-V1,-V2,+V3)
12	Common(-V1,-V2,+V3)
13	Common(-V1,-V2,+V3)
14	+V1
15	+V1
16	+V1
17	DC Good return
18	DC Good

**ENVIRONMENTAL SPECIFICATIONS**

**(STANDARD MODEL)**

SPECIFICATION	CONDITIONS	RANGE
Temperature	Operating with derating above 50°C	0° to 60°C
	Non-operating	-30°C to +85°C
Vibration	MIL-STD-810E for Transportation	

J1	AC INPUT
1	Line
3	Neutral
5	Ground

Notes:

- Short circuit protection on auxiliaries is limited to 30 seconds or damage/failure to unit may occur.
- Outputs V1, V2 and V3 return through the common terminal, output V4 is isolated and returns through its return terminal -V4.
- 200 mA required on V3 for specified line and load regulation on V3. Output V3 will remain within initial accuracy's at no load.

Notes continued:

- Operation of the unit between the line voltages of 132 and 180Vac for greater than 30 seconds will cause catastrophic failure to the unit.
- Grounding with PCB only option (N option). Protection requires that J1 pin 5 and all pads around the 5 mounting holes be bonded to protective earth in the end application. Conductive spacers should be used to mount the supply to metal surfaces. When mounting the power supply to non-conductive surfaces the 5 mounting pads should be bonded to J1 pin 5 and bonded to earth.
- All outputs are derated with either the Z option (cover) or the N option (PCB only) chosen, see derating table.
- Proper air circulation is required when the unit is mounted in confined areas.
- Remote on/off - J6 is a primary referenced connector located in the center of the unit.

Short J6 terminals = unit off, open J6 terminals = unit on

Note: This is a primary referenced circuit and requires proper agency clearances.

The use of a opto isolator is recommended.

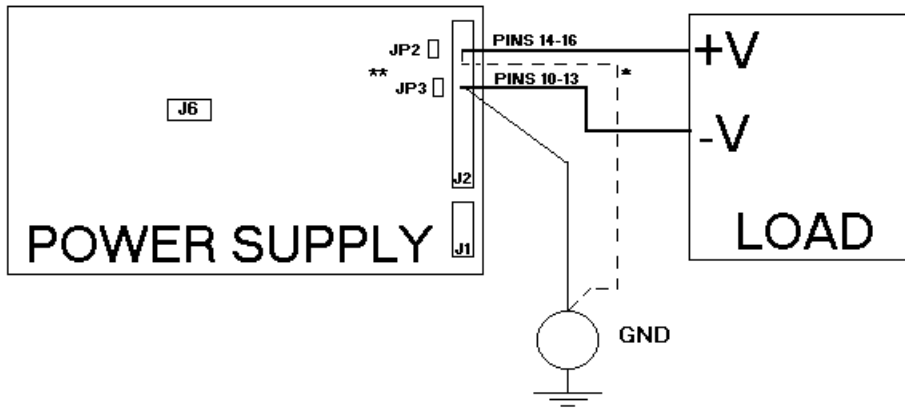

\* For positive ground, move the -V to gnd jumper to +V to gnd, as shown with dashed line.  
 \*\* JP2 and JP3 must be installed for unit to operate in local sense mode.

Figure 1 Typical Local Sense Connection

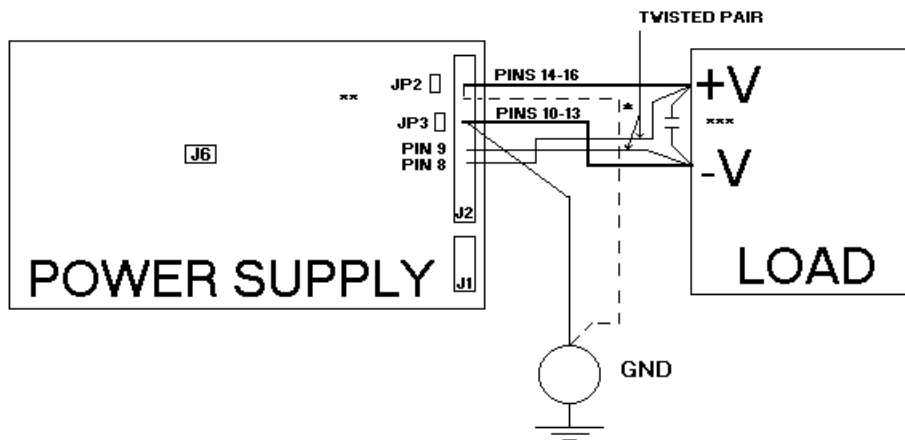

\* For positive ground, move the -V to gnd jumper to +V to gnd, as shown with dashed line.  
 \*\* JP2 and JP3 must be removed for unit to operate in remote sense mode.  
 Remote sense minimizes the effects of distribution losses by regulating the voltage at the remote sense connections.  
 Good layout techniques, such as close proximity and directness, should be observed for noise immunity.  
 \*\*\* Suitable decoupling capacitor (0.1uF, or higher) may be required at load.

Figure 2 Typical Remote Sense Connection

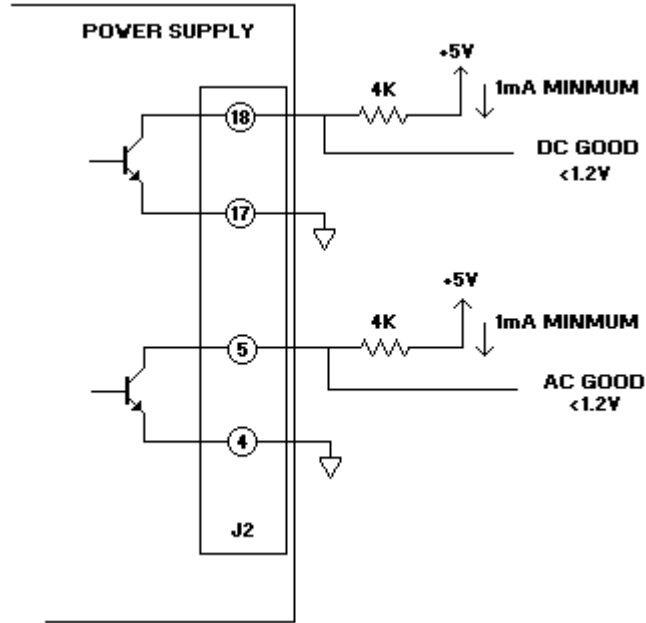
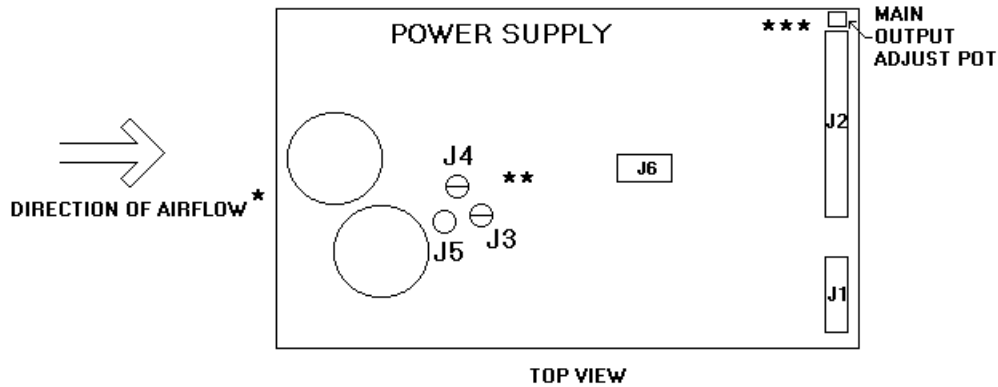

Figure 3 Typical DC and AC Good Signal Connections



- \* 125 LFM in the direction shown is required for maximum output power (130W).
- \*\* Jumper location for AC mains select option (A option). Connect J5 to J3 for 115 VAC operation and J5 to J4 for 230 VAC operation.
- \*\*\* The main output voltage may be adjusted using the adjustment potentiometer shown.

Figure 4 Location of AC Mains Selector, Output Voltage Adjustment Potentiometer and Direction of Airflow

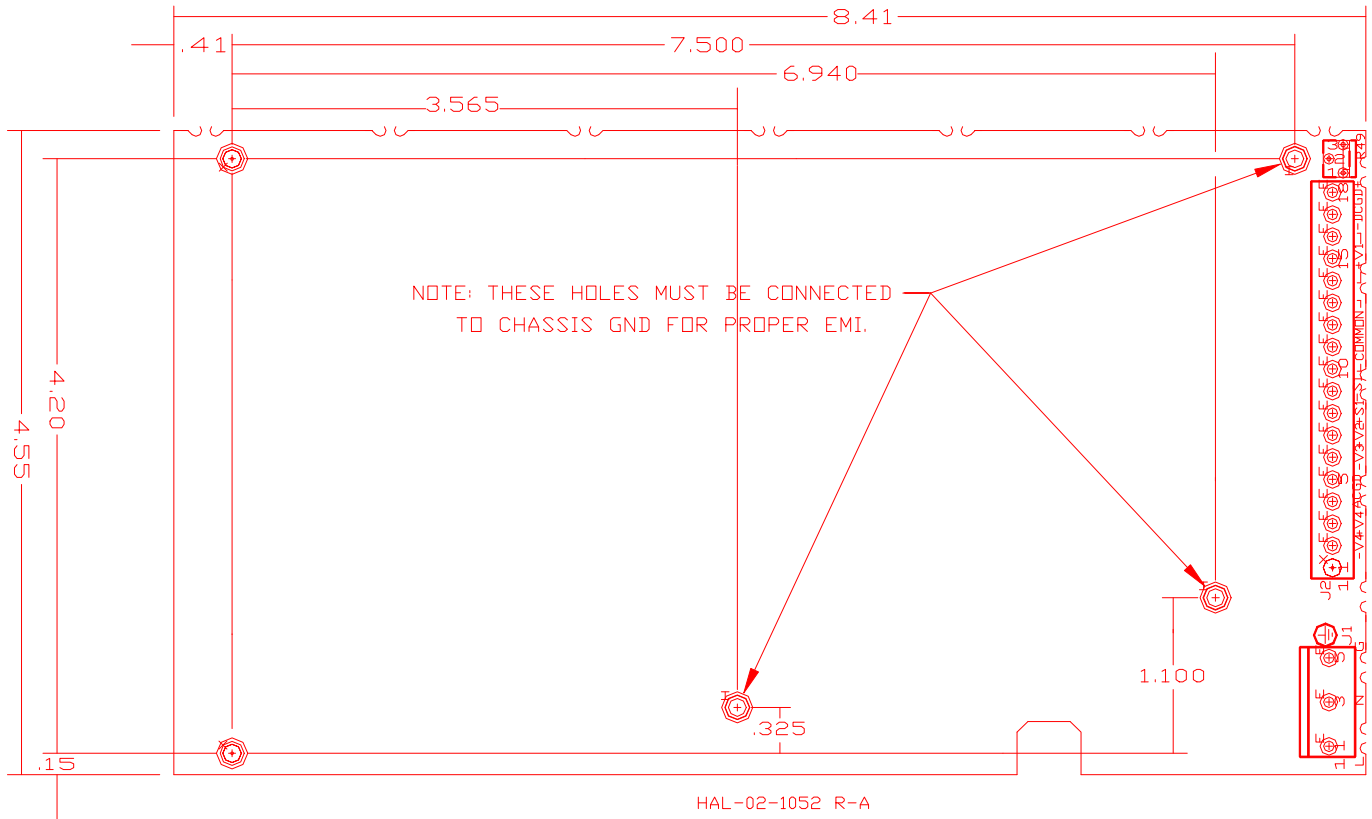

Figure 5 Outline drawing for -N option

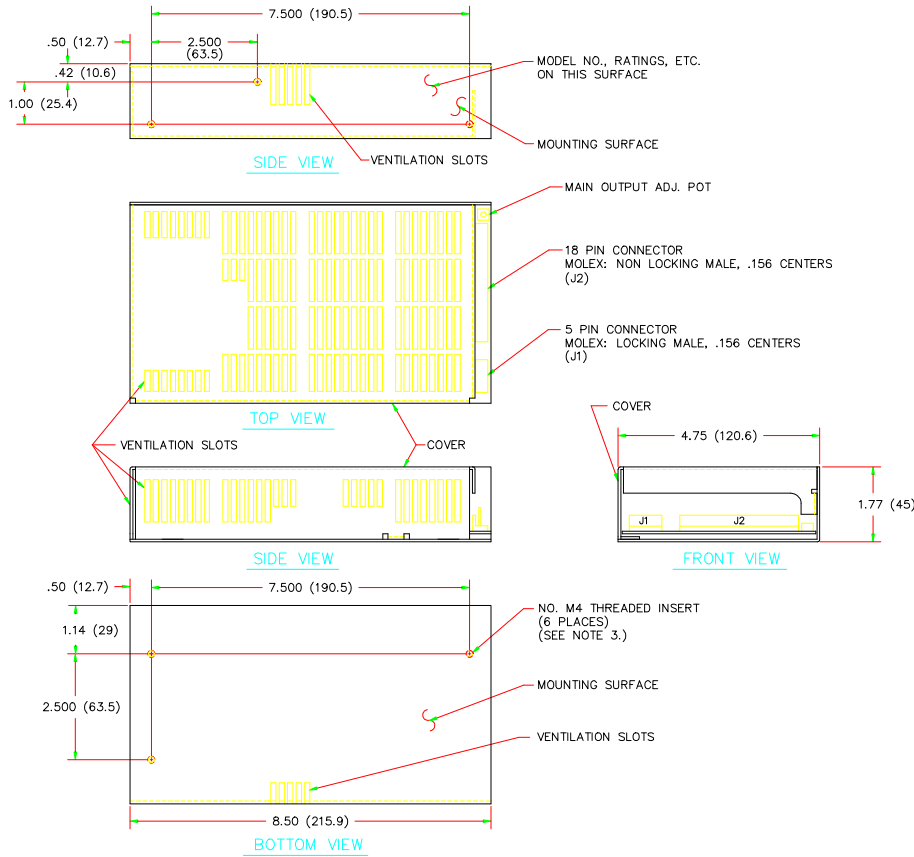

TABLE OF WEIGHTS		
MODEL	NET (LBS.)	SHIPPING (LBS.)
SVQ130 (NO COVER)	2	3
(WITH COVER)	2.5 LBS.	3.5 LBS.

NOTE:

1. UNIT IS SUPPLIED WITH OR WITHOUT COVER.
2. CUSTOMER MOUNTING SCREWS (NO. M4) MUST NOT PROTRUDE INTO POWER SUPPLY BY MORE THAN 1/4 INCH (6.3)
3. DIMENSIONS ARE IN INCHES EXCEPT DIMENSIONS IN ( ) ARE IN MM.
4. CONNECTOR REQUIREMENTS:  
 J1 MATING CONNECTOR: MOLEX PART NO. 09-50-8051  
 J2 MATING CONNECTOR: MOLEX PART NO. 09-50-8180  
 J1 AND J2 CRIMP TERMINALS: MOLEX PART NO. 08-50-0106
5. THICKNESS OF SHEETMETAL IS 0.062