

SURFACE MOUNT CERMET TRIMMERS

SM-42/43

RoHS compliant



INTERNAL STRUCTURE

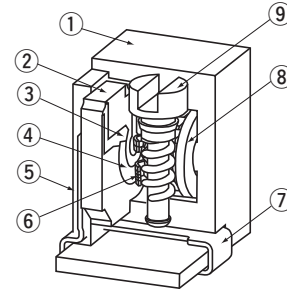

FEATURES

- RoHS compliant
- Fine adjustment is available
- Automatic mounting is available (Taping)
- Reflow soldering is available
- Sealed construction (Washable)

| | Part name | Material | Flammability |
|---|-------------------|----------------------------|--------------|
| ① | Housing | Polyphenylenesulphide | UL-94V-0 |
| ② | Base element | Ceramic | — |
| ③ | Electrode | Ag-Pd cermet | |
| ④ | Resistive element | RuO ₂ cermet | UL-94V-0 |
| ⑤ | Adhesive | Epoxy | |
| ⑥ | Wiper | Multi metal alloy | — |
| ⑦ | Terminal pin | Copper alloy, Sn-Cu-plated | |
| ⑧ | Rotor gear | Polyamide | UL-94V-0 |
| ⑨ | Shaft | Brass, Nickel-plated | — |

PART NUMBER DESIGNATION

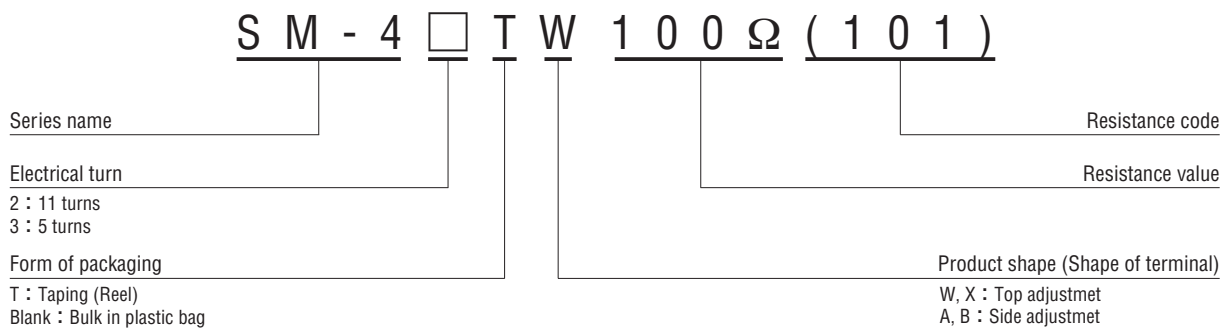

※Please refer to the LIST OF PART NUMBERS when placing orders.

SM-42/43

SURFACE MOUNT TRIMMERS

LIST OF PART NUMBERS

| Electrical turn | Adjustment position | Shape of terminal | Form of packaging | |
|-------------------|---------------------|-------------------|--|--------------|
| | | | Taping (reel) | Plastic bag |
| 11 | Top adjustment | W (J-hook) | SM-42TW | SM-42W |
| | | X (Gull wing) | SM-42TX | SM-42X |
| | Side adjustment | A (J-hook) | SM-42TA | SM-42A |
| | | B (Gull wing) | SM-42TB | SM-42B |
| 5 | Top adjustment | W (J-hook) | SM-43TW | SM-43W |
| | | X (Gull wing) | SM-43TX | SM-43X |
| | Side adjustment | A (J-hook) | SM-43TA | SM-43A |
| | | B (Gull wing) | SM-43TB | SM-43B |
| Pieces in package | | | TA, TB : 500 pcs./reel TW, TX : 250 pcs./reel | 50 pcs./pack |

ELECTRICAL CHARACTERISTICS

| | |
|---------------------------|---|
| Nominal resistance range | 10 Ω ~ 2 MΩ |
| Resistance tolerance | ± 10 % |
| Power ratings | 0.25 W (85 °C) 0 W (150 °C) |
| Resistance law | Linear law |
| Maximum input voltage | DC300 V or power rating, whichever is smaller |
| Maximum wiper current | 100 mA or power rating, whichever is smaller |
| Effective electrical turn | 11 turns (SM-42), 5 turns (SM-43) |
| End resistance | 1 % or 2 Ω, whichever is greater |
| C.R.V. | 1 % or 3 Ω, whichever is greater |
| Operating temp. range | -65 ~ 150 °C |
| Temp. coefficient | ±100 10 ⁻⁶ /°C maximum |
| Insulation resistance | 100 MΩ minimum (DC500 V) |
| Dielectric strength | AC600 V, 60 s |
| Net weight | Approx. 0.17 g |

<Reflow profile for soldering heat evaluation>

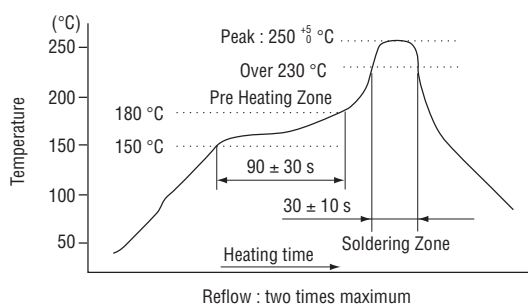

<Nominal resistance values>

| | | | | | | | | |
|--------|--------|-------|--------|--------|--------|------|------|------|
| ↻ 10 Ω | ↻ 20 Ω | 50 Ω | 100 Ω | 200 Ω | 500 Ω | 1 kΩ | 2 kΩ | 5 kΩ |
| 10 kΩ | 20 kΩ | 50 kΩ | 100 kΩ | 200 kΩ | 500 kΩ | 1 MΩ | 2 MΩ | |

Fig. 1

The products indicated by ↻ mark are manufactured upon receipt of order basis.

※The above part numbers are all available with the respective combination of <Nominal resistance values> (Fig. 1).

※Verify the above part numbers when placing orders.

※Taping specification is not sold separately and must be purchased in reel units.

MECHANICAL CHARACTERISTICS

| | |
|-------------------|-------------------------------------|
| Operating torque | 17.6 mN·m (180 gf·cm) maximum |
| Mechanical stop | Clutch action |
| Rotational life | 200 cycles [ΔR/R ≤ ± (3 Ω + 3 %)] |
| Thrust to shaft | 5 N (0.51 kgf) minimum |
| Solderability | 245 ± 3 °C, 2 ~ 3 s |
| Shear (Adhesion) | 5 N (0.51 kgf) 10 s |
| Substrate bending | Width 90 mm, bend 3 mm, 5 s, 1 time |
| Pull-off strength | 5 N (0.51 kgf) 10 s |

{ } : Reference only

ENVIRONMENTAL CHARACTERISTICS

| Test item | Test conditions | Specifications |
|---------------------|---|---|
| Thermal shock | -65 ~ 150 °C (0.5 h), 5 cycles | [ΔR/R ≤ 2 %] [S.S. ≤ 1 %] |
| Humidity | -10 ~ 65 °C (80 ~ 98 %), 10 cycles, 240 h | [ΔR/R ≤ 2 %] |
| Shock | 981 m/s ² , 6 ms 6 directions for 3 times each | [ΔR/R ≤ 1 %] [S.S. ≤ 1 %] |
| Vibration | Amplitude 1.52 mm or Acceleration 196 m/s ² , 10 ~ 2000 Hz, 3 directions, 12 times each | [ΔR/R ≤ 1 %] [S.S. ≤ 1 %] |
| Load life | 85 °C, 0.25 W, 1000 h | [ΔR/R ≤ 3 % or 3 Ω] [S.S. ≤ 2 %] |
| Low temp. operation | -65 °C, 2 h | [ΔR/R ≤ 1 %] [S.S. ≤ 1 %] |
| High temp. exposure | 150 °C, 250 h | [ΔR/R ≤ 2 %] [S.S. ≤ 1 %] |
| Immersion seal | 85 °C, 60 s | No leaks (No continuous bubbles) |
| Soldering heat | Reflow : Peak temperature 255 °C (Please refer to the profile below.) Manual soldering : 350 ± 10 °C, 3 ~ 4 s | [ΔR/R ≤ 1 %] |

ΔR/R : Change in total resistance
S.S. : Setting stability

SM-42/43

SURFACE MOUNT TRIMMERS

MAXIMUM INPUT RATINGS

| Nominal resistance values (Ω) | Resistance code | Maximum input voltage (V) | Maximum wiper current (mA) |
|-------------------------------|-----------------|---------------------------|----------------------------|
| ⤴ 10 | 100 | 1.00 | 100 |
| ⤴ 20 | 200 | 2.00 | 100 |
| 50 | 500 | 3.53 | 70.7 |
| 100 | 101 | 5.00 | 50.0 |
| 200 | 201 | 7.07 | 35.4 |
| 500 | 501 | 11.2 | 22.4 |
| 1 k | 102 | 15.8 | 15.8 |
| 2 k | 202 | 22.4 | 11.2 |
| 5 k | 502 | 35.4 | 7.07 |
| 10 k | 103 | 50.0 | 5.00 |
| 20 k | 203 | 70.7 | 3.54 |
| 50 k | 503 | 112 | 2.24 |
| 100 k | 104 | 158 | 1.58 |
| 200 k | 204 | 223 | 1.12 |
| 500 k | 504 | 300 | 0.60 |
| 1 M | 105 | 300 | 0.30 |
| 2 M | 205 | 300 | 0.15 |

The products indicated by ⤴ mark are manufactured upon receipt of order basis.

RECOMMENDED P.C.B. PAD OUTLINE DIMENSIONS

(Unit: mm)

● SM-42/43A

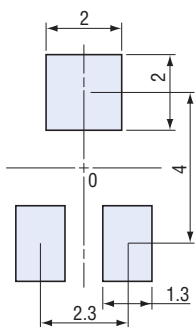

● SM-42/43B

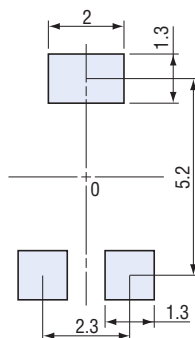

● SM-42/43W

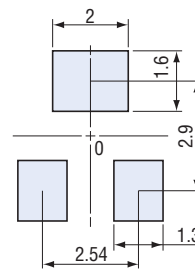

● SM-42/43X

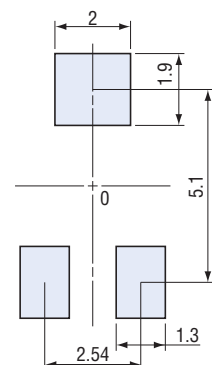

Note) The zero point is the center of mounting.

SM-42/43

SURFACE MOUNT TRIMMERS

OUTLINE DIMENSIONS

Unless otherwise specified, tolerance : ± 0.3 (Unit : mm)

● SM-42/43W

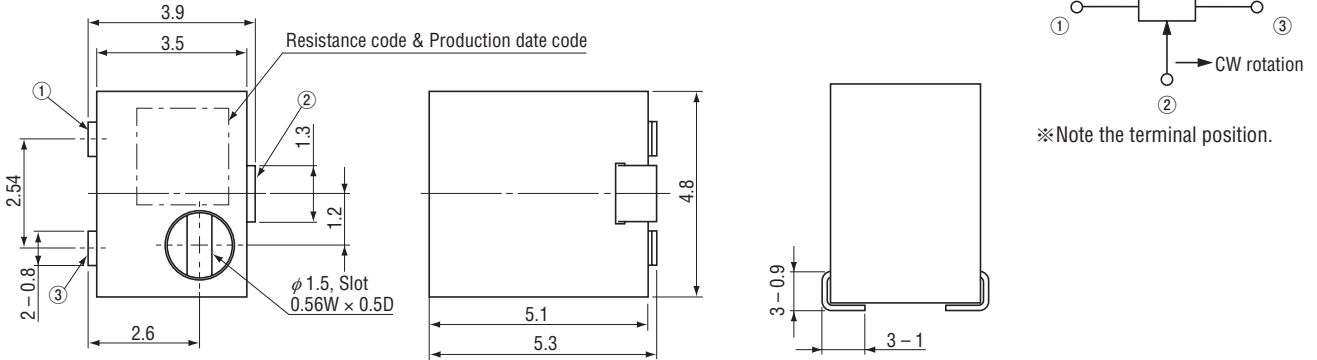

● SM-42/43X

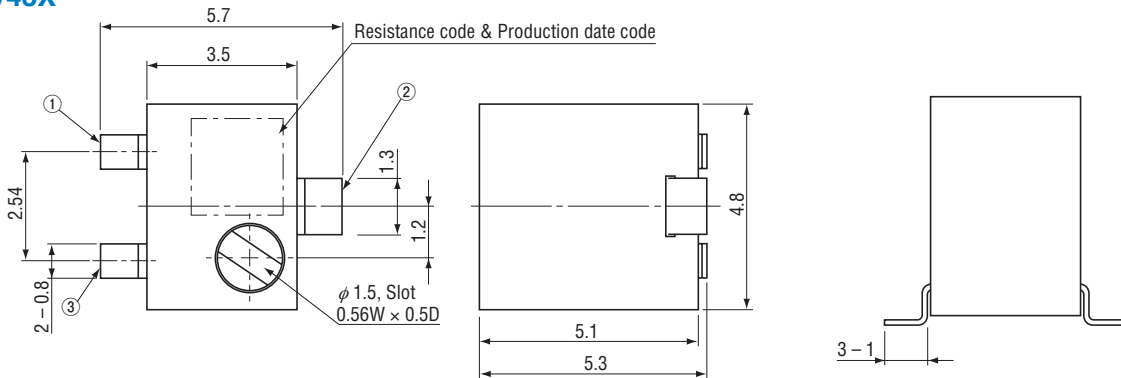

● SM-42/43A

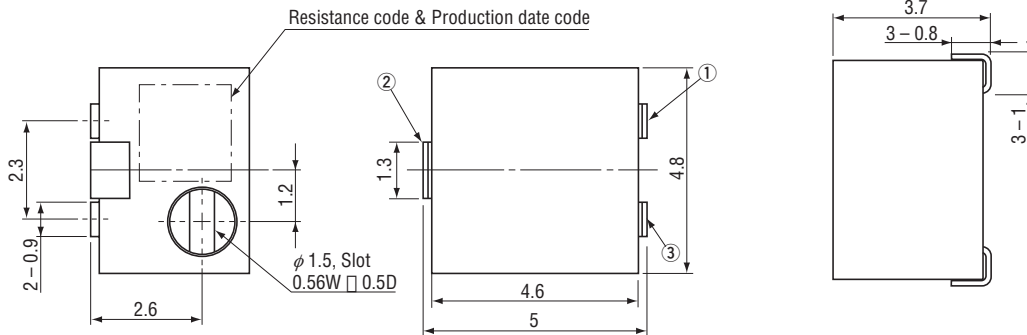

● SM-42/43B

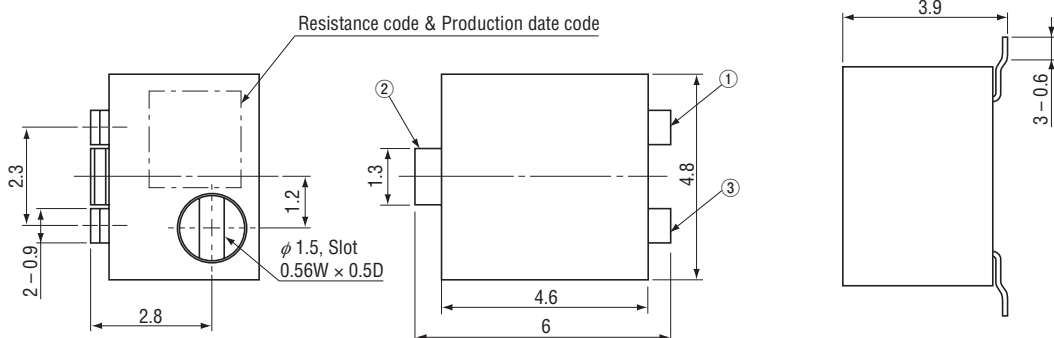

SM-42/43

SURFACE MOUNT TRIMMERS

PACKAGING SPECIFICATIONS

<Taping packaging specifications>

- Taping version (SM-42/43TA, TB) is packaged in 500 pcs. per reel.
Orders will be accepted for units of 500 pcs., i.e., 500, 1000, 1500 pcs., etc.
- SM-42/43TW, TX is packaged in 250 pcs. per reel.
Orders will be accepted for units of 250 pcs., i.e., 500, 750 pcs., etc.

Maximum number of consecutive missing pieces = 2
Leader length and reel dimension are shown in the diagrams below.

EMBOSSED TAPE DIMENSIONS

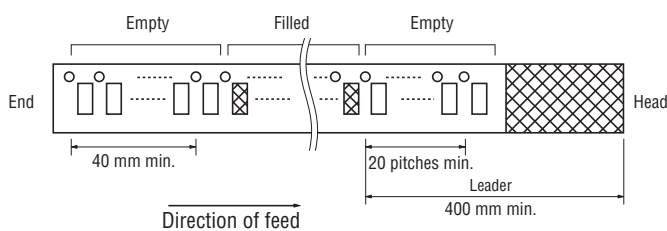

REEL DIMENSIONS

(Conforms to JIS C 0806-3)
(TA/TB type : In accordance with EIAJ ET-7200A)

(Unit: mm)

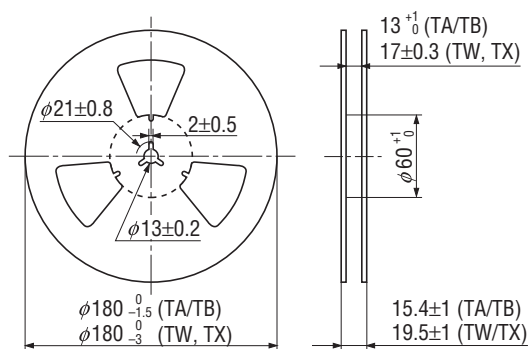

SM-42/43TW/TX

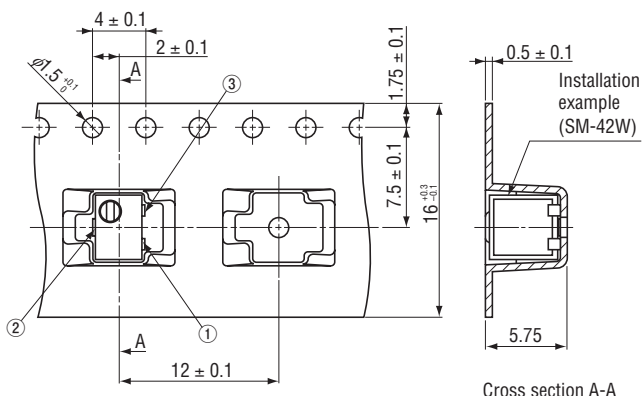

SM-42/43TA/TB

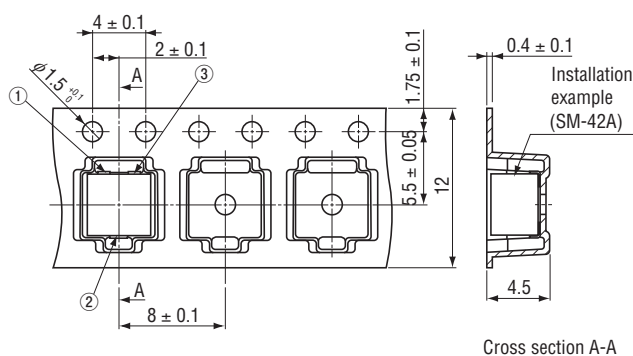

<Bulk pack specifications>

- Unit of bulk in a plastic bag is 50 pcs. per pack.
- Boxing of bulk in a plastic bag is performed with 200 pcs. per box.