

版数 REV.	年月日 DATE	DCN NO.	変更内容 DESCRIPTION	製図 DR.	担当 CHK.	承認 APPD.	承認 APPD.
2	21.Jan.2005	056356	CHANGED FORM		J.MOTOJIMA		A.NATORI
3	6.Mar.2008	065194	CORRECT ERROR IN WRITING		J.MOTOJIMA		A.NATORI

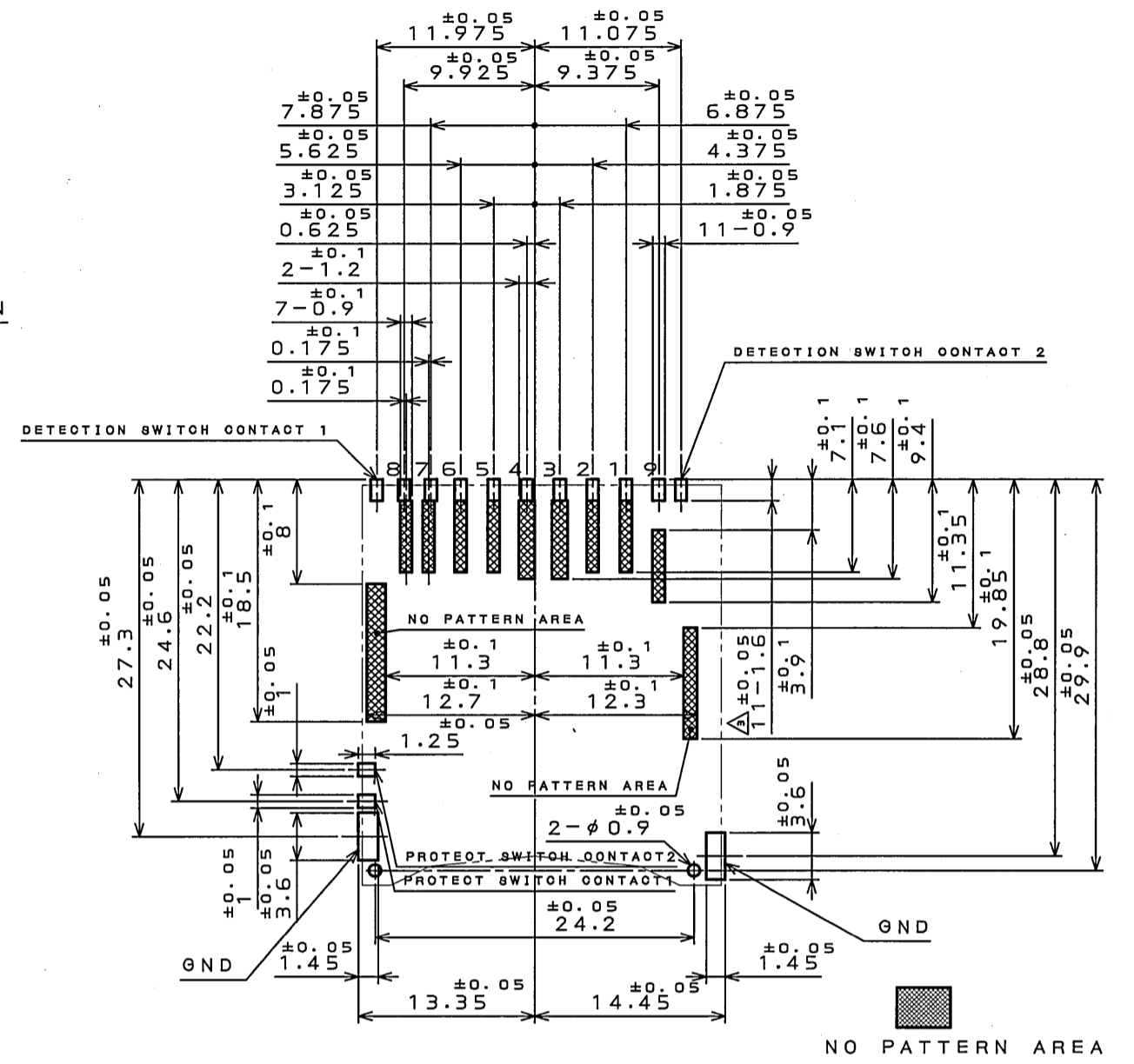

APPLICABLE P.C.B. DIMENSION (REF.)  
適合基板寸法 (参考)

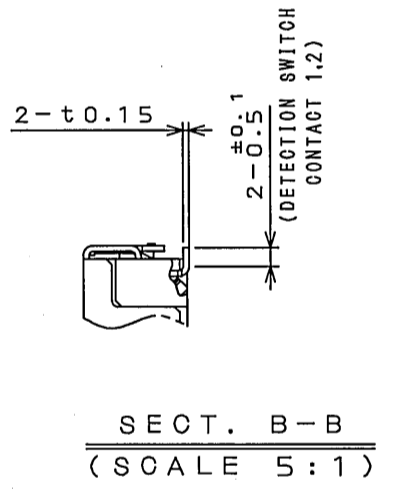
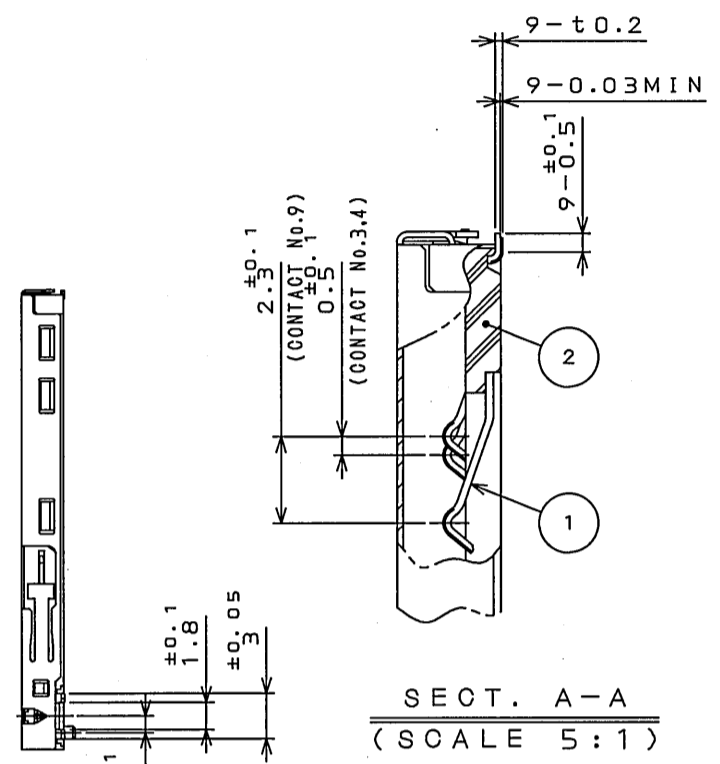
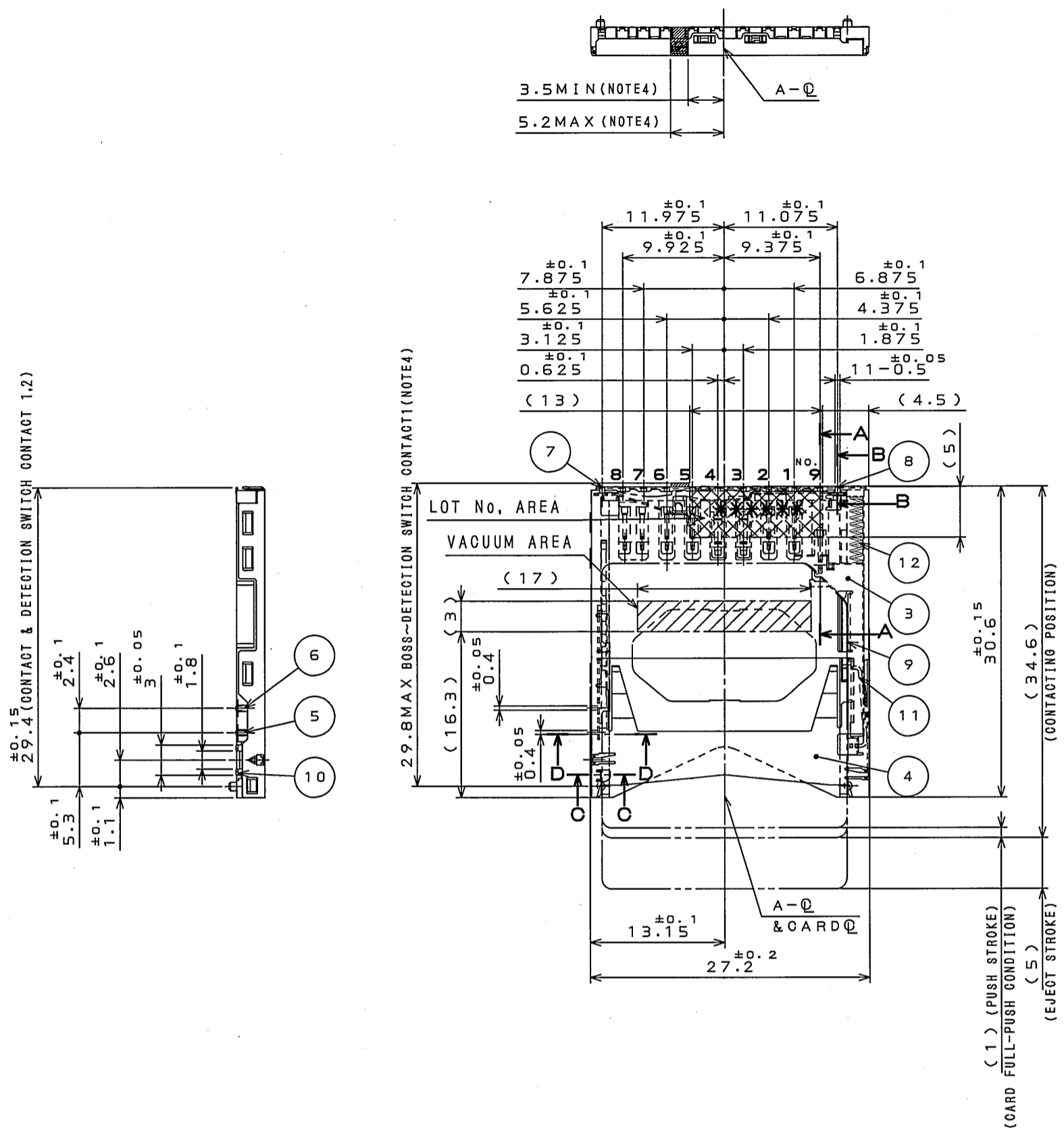
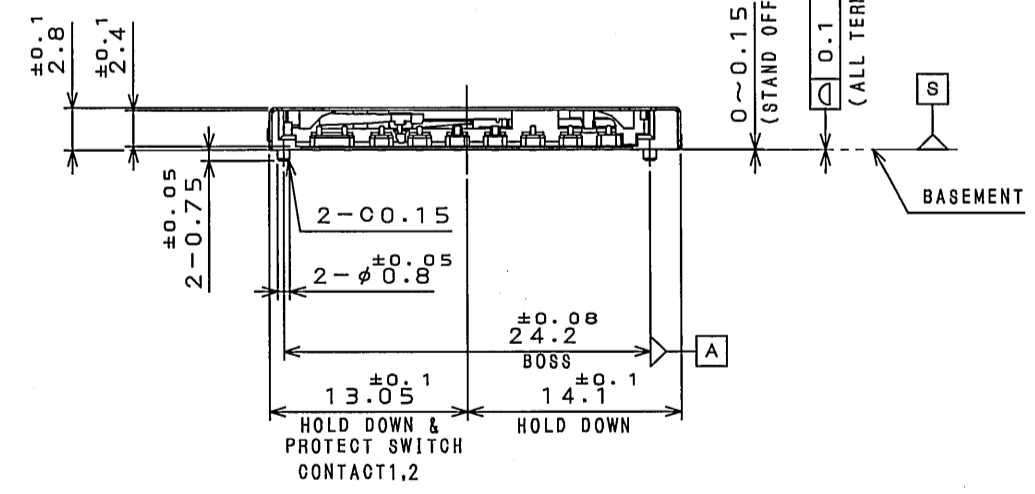
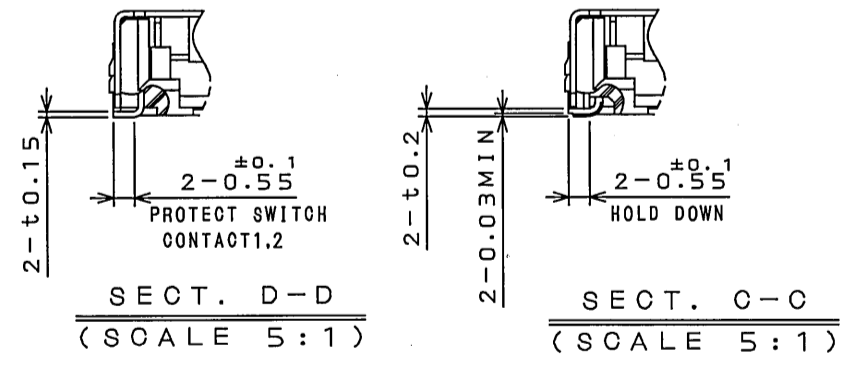

NOTE1. Card Frictional locking function is available for inserted SD card only but not for MMC.  
NOTE2. The thickness of reinforcement board is 0.6MIN, when the product will mount on FPC.  
NOTE3. CIRCUIT (TABLE.1) (REFERENCE)  
NOTE4. External form dimensions in CARD FULL-PUSH condition. (No parts in this area.)

注1. カードロック機能は、SDカードのみの対応と致します。(MMCでは作動しません)  
注2. FPC搭載時の補強板厚は0.6以上とする。  
注3. 回路図(表1)(参考)  
注4. カード突き当て状態における外形寸法(本領域に部品を搭載しないで下さい。)

TABLE 1. CIRCUIT (REF.)

	CIRCUIT (REF.)			
	WITHOUT CARD	CARD INSERTED		
		WRITE PROTECT: LOCK	WRITE PROTECT: UNLOCK	
PROTECT SWITCH	5 - 6	5 - 6	5 - 6	
DETECTION SWITCH	7 - 8	7 - 8	7 - 8	

NO.	DESCRIPTION	QTY.	MATERIAL	FINISH	REMARKS
12	SPRING	1	PIANO WIRE	ZINC PLATING	
11	CAM FOLLOWER	1	STAINLESS		
10	HOLD DOWN	2	COPPER ALLOY	GOLD FLASH OVER NICKEL	
9	CARD LOCK	1	STAINLESS		
8	DETECTION SWITCH CONTACT2	1	COPPER ALLOY	CONTACTING AREA: GOLD OVER NICKEL TERMINAL AREA: GOLD FLASH OVER NICKEL	
7	DETECTION SWITCH CONTACT1	1	COPPER ALLOY	CONTACTING AREA: GOLD OVER NICKEL TERMINAL AREA: GOLD FLASH OVER NICKEL	
6	PROTECT SWITCH CONTACT2	1	COPPER ALLOY	CONTACTING AREA: GOLD OVER NICKEL TERMINAL AREA: GOLD FLASH OVER NICKEL	
5	PROTECT SWITCH CONTACT1	1	COPPER ALLOY	CONTACTING AREA: GOLD OVER NICKEL TERMINAL AREA: GOLD FLASH OVER NICKEL	
4	COVER FRAME	1	STAINLESS		
3	EJECT BAR	1	GLASS FILLED NY		UL94 V-0
2	HOUSING	1	GLASS FILLED LCP		UL94 V-0
1	CONTACT	9	COPPER ALLOY	CONTACTING AREA: GOLD OVER NICKEL TERMINAL AREA: GOLD FLASH OVER NICKEL	

仕様書 (SPECIFICATION)	JACS-1759-*	第1版 (ORIGINAL DATE)	18.Jul.2003	製図 (SCALE)	2:1	シリーズ (SERIES)	S95	製図 DR.	J.MOTOJIMA	承認 APPD.	K.SUZUKI	名称 (TITLE)	S05S009V1A1	質量 (MASS)		図面番号 (DRAWING NO.)	SJ038633	版数 (REV.)	3
---------------------	-------------	---------------------	-------------	------------	-----	---------------	-----	--------	------------	----------	----------	------------	-------------	-----------	--	--------------------	----------	-----------	---