



MICROCHIP

PIC18F2331/2431/4331/4431

FLASH Microcontroller Programming Specification

1.0 DEVICE OVERVIEW

This document includes the programming specifications for the following devices:

- PIC18F2331
- PIC18F2431
- PIC18F4331
- PIC18F4431

2.0 PROGRAMMING OVERVIEW OF THE PIC18FXX31

PIC18FXX31 devices can be programmed using either the high voltage In-Circuit Serial Programming™ (ICSP™) method, or the low voltage ICSP method. Both of these can be done with the device in the users' system. The low voltage ICSP method is slightly different than the high voltage method, and these differences are noted where applicable. This programming specification applies to PIC18FXX31 devices in all package types.

2.1 Hardware Requirements

In High Voltage ICSP mode, the PIC18FXX31 requires two programmable power supplies: one for VDD and one for MCLR/VPP. Both supplies should have a minimum resolution of 0.25V. Refer to Section 6.0 for additional hardware parameters.

2.1.1 LOW VOLTAGE ICSP PROGRAMMING

In Low Voltage ICSP mode, the PIC18FXX31 can be programmed using a VDD source in the operating range. This only means that MCLR/VPP does not have to be brought to a different voltage but can instead be left at the normal operating voltage. Refer to Section 6.0 for additional hardware parameters.

2.2 Pin Diagrams

The pin diagrams for the PIC18FXX31 family are shown in Figure 2-1, Figure 2-2, and Figure 2-3. The pin descriptions of these diagrams do not represent the complete functionality of the device types. Users should refer to the appropriate device data sheet for complete pin descriptions.

TABLE 2-1: PIN DESCRIPTIONS (DURING PROGRAMMING): PIC18FXX31

Pin Name	During Programming		
	Pin Name	Pin Type	Pin Description
MCLR/VPP	VPP	P	Programming Enable
VDD ⁽²⁾	VDD	P	Power Supply
VSS ⁽²⁾	VSS	P	Ground
AVDD	AVDD	P	Analog Power Supply
AVSS	AVSS	P	Analog Ground
RB5	PGM	I	Low Voltage ICSP Input when LVP Configuration bit equals '1' ⁽¹⁾
RB6	SCLK	I	Serial Clock
RB7	SDATA	I/O	Serial Data

Legend: I = Input, O = Output, P = Power

Note 1: See Section 5.3 for more detail.

2: All power supply and ground must be connected, including AVDD and AVSS.

PIC18F2331/2431/4331/4431

FIGURE 2-1: PIN DIAGRAMS

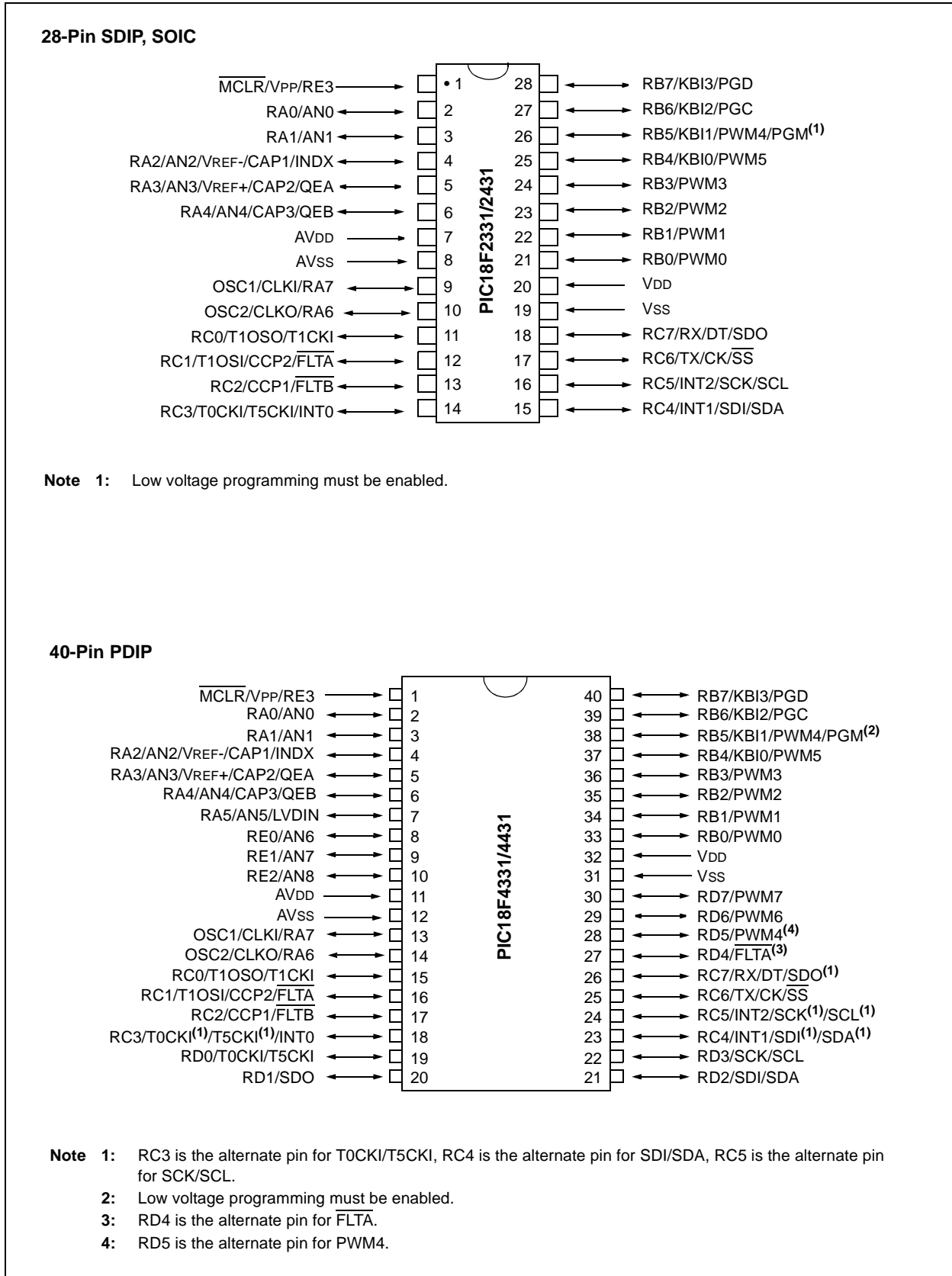

PIC18F2331/2431/4331/4431

FIGURE 2-2: PIN DIAGRAMS (CONTINUED)

44-Pin TQFP

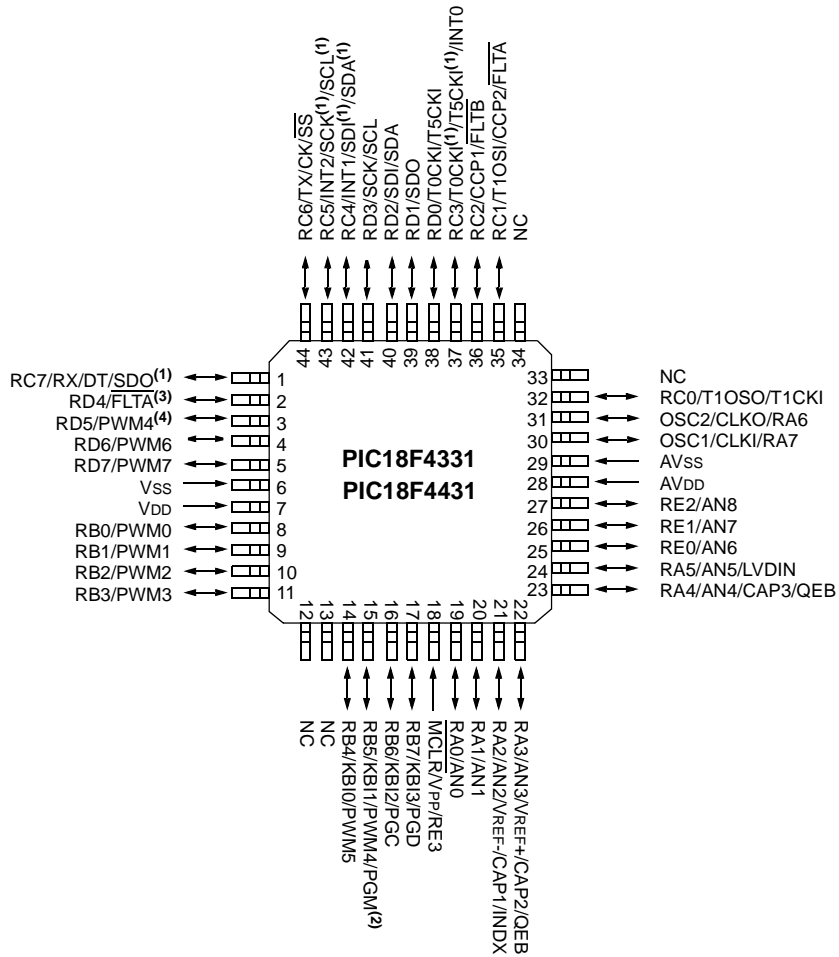

- Note 1:** RC3 is the alternate pin for T0CKI/T5CKI, RC4 is the alternate pin for SDI/SDA, RC5 is the alternate pin for SCK/SCL.
- Note 2:** Low voltage programming must be enabled.
- Note 3:** RD4 is the alternate pin for FLTA.
- Note 4:** RD5 is the alternate pin for PWM4.

PIC18F2331/2431/4331/4431

FIGURE 2-3: PIN DIAGRAMS (CONTINUED)

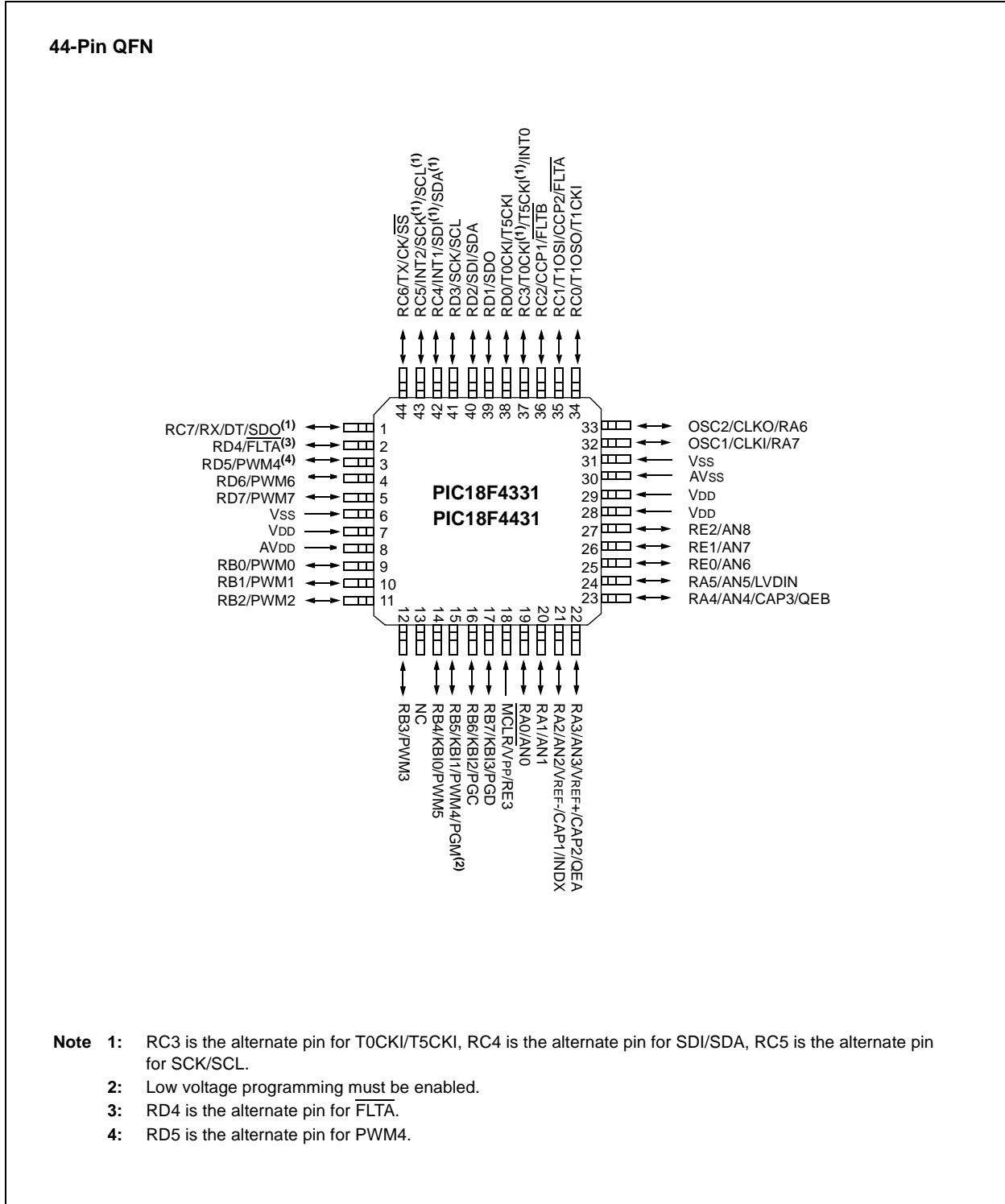

PIC18F2331/2431/4331/4431

2.3 Memory Map

The code memory space extends from 0000h to 3FFFh (16 Kbytes) in four 4-Kbyte blocks. Addresses 0000h through 01FFh, however, define a “Boot Block” region that is treated separately from Block 0. All of these blocks define code protection boundaries within the code memory space.

In contrast, code memory panels are defined in 8-Kbyte boundaries. Panels are discussed in greater detail in Section 3.2.

TABLE 2-2: IMPLEMENTATION OF CODE MEMORY

Device	Code Memory Size (Bytes)
PIC18F2331	000000h - 001FFFh (8K)
PIC18F4331	
PIC18F2431	000000h - 003FFFh (16K)
PIC18F4431	

FIGURE 2-4: MEMORY MAP AND THE CODE MEMORY SPACE FOR PIC18FXX31 DEVICES

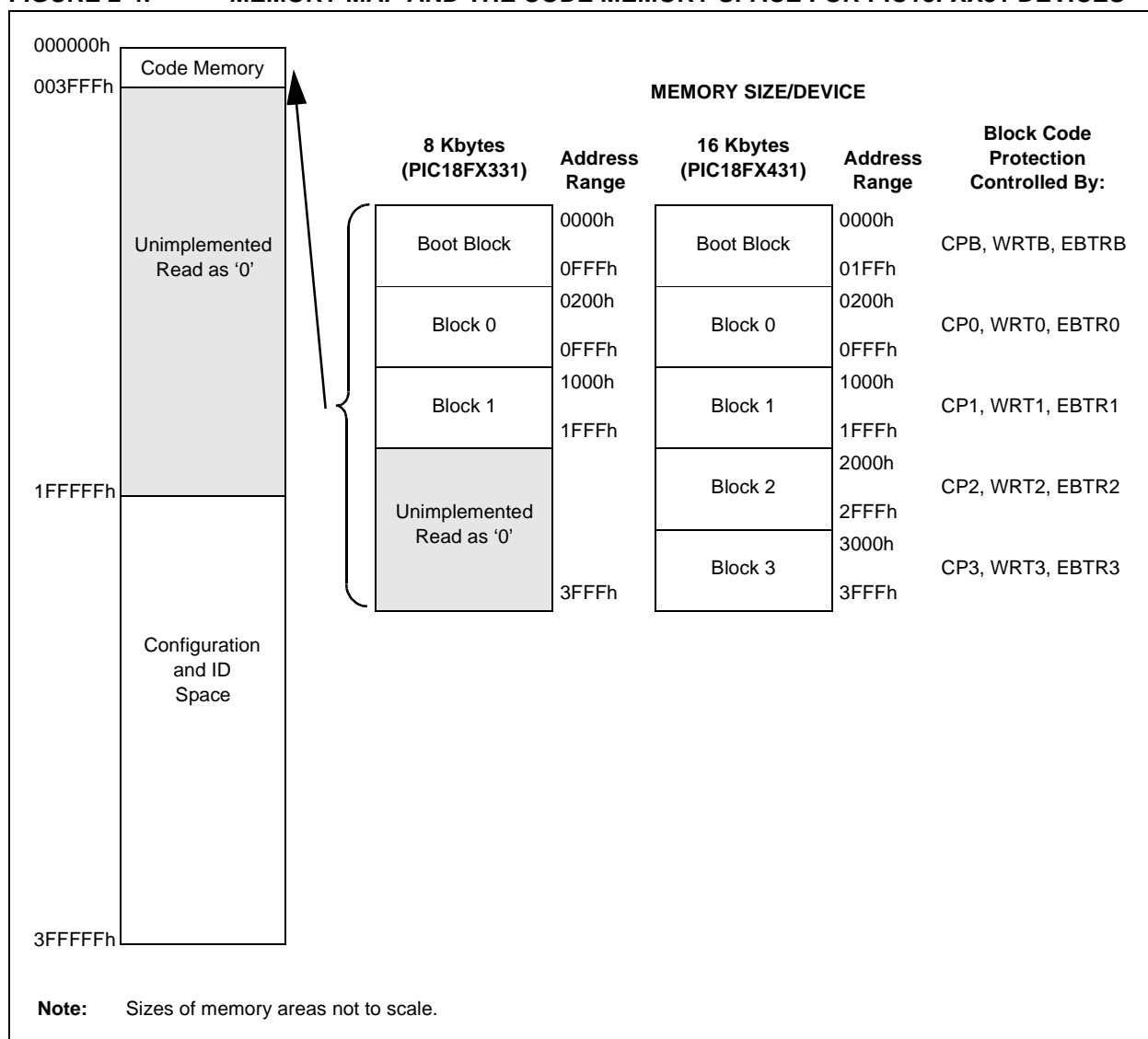

PIC18F2331/2431/4331/4431

In addition to the code memory space, there are three blocks in the configuration and ID space that are accessible to the user through table reads and table writes. Their locations in the memory map are shown in Figure 2-5.

Users may store identification information (ID) in eight ID registers. These ID registers are mapped in addresses 200000h through 200007h. The ID locations read out normally even after code protection is applied.

Locations 300000h through 30000Dh are reserved for the configuration bits. These bits select various device options and are described in Section 5.0. These configuration bits read out normally even after code protection.

Locations 3FFFEh and 3FFFFh are reserved for the device ID bits. These bits may be used by the programmer to identify what device type is being programmed and are described in Section 5.0. These device ID bits read out normally even after code protection.

2.3.1 MEMORY ADDRESS POINTER

Memory in the address space 000000h to 3FFFFFFh is addressed via the table pointer which is comprised of three pointer registers:

- TBLPTRU, at RAM address 0FF8h
- TBLPTRH, at RAM address 0FF7h
- TBLPTRL, at RAM address 0FF6h

TBLPTRU	TBLPTRH	TBLPTRL
Addr[21:16]	Addr[15:8]	Addr[7:0]

The 4-bit command, '0000' (core instruction), is used to load the table pointer prior to using many read or write operations.

FIGURE 2-5: CONFIGURATION AND ID LOCATIONS FOR PIC18FXX31 DEVICES

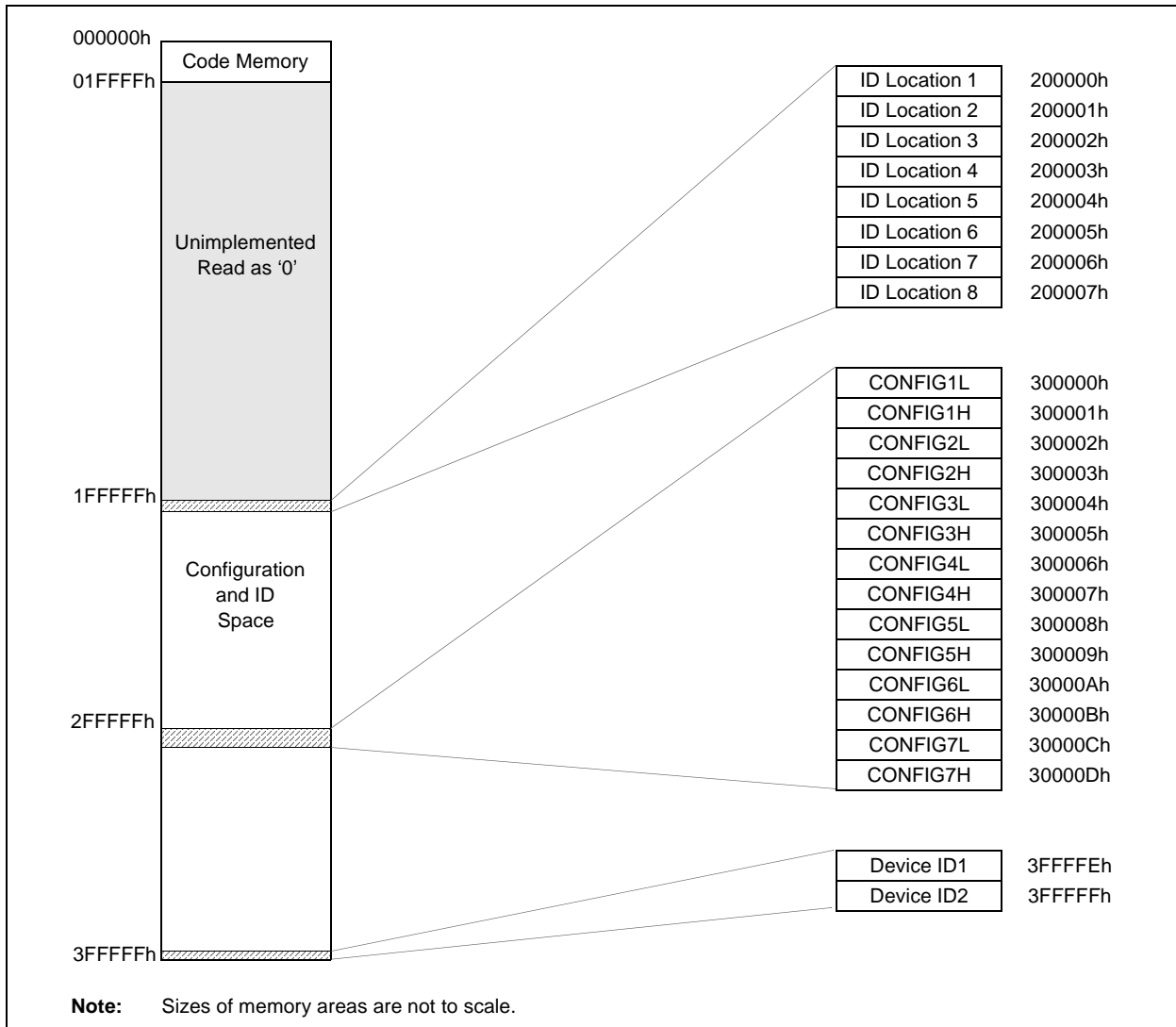

2.4 High Level Overview of the Programming Process

Figure 2-7 shows the high level overview of the programming process. First, a bulk erase is performed. Next, the code memory, ID locations, and data EEPROM are programmed. These memories are then verified to ensure that programming was successful. If no errors are detected, the configuration bits are then programmed and verified.

2.5 Entering High Voltage ICSP Program/Verify Mode

The High Voltage ICSP Program/Verify mode is entered by holding SCLK and SDATA low and then raising $\overline{\text{MCLR}}/\text{VPP}$ to V_{IH} (high voltage). Once in this mode, the code memory, data EEPROM, ID locations, and configuration bits can be accessed and programmed in serial fashion.

The sequence that enters the device into the Program/Verify mode places all unused I/Os in the high impedance state.

2.5.1 ENTERING LOW VOLTAGE ICSP PROGRAM/VERIFY MODE

When the LVP configuration bit is '1' (see Section 5.3), the Low Voltage ICSP mode is enabled. Low Voltage ICSP Program/Verify mode is entered by holding SCLK and SDATA low, placing a logic high on PGM, and then raising $\overline{\text{MCLR}}/\text{VPP}$ to V_{IH} . In this mode, the RB5/PGM pin is dedicated to the programming function and ceases to be a general purpose I/O pin.

The sequence that enters the device into the Program/Verify mode places all unused I/Os in the high impedance state.

FIGURE 2-7: HIGH LEVEL PROGRAMMING FLOW

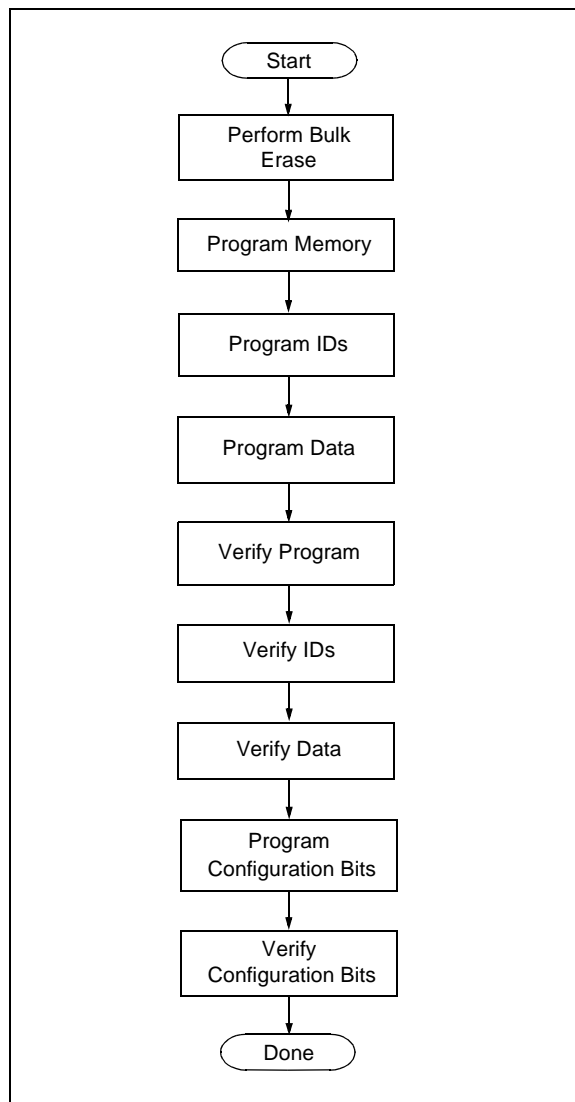

FIGURE 2-6: ENTERING HIGH VOLTAGE PROGRAM/VERIFY MODE

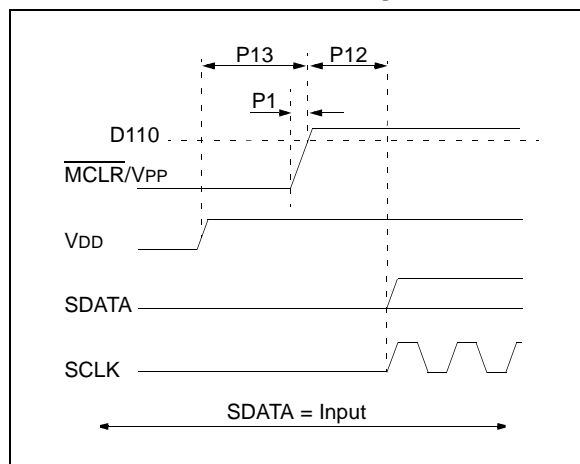
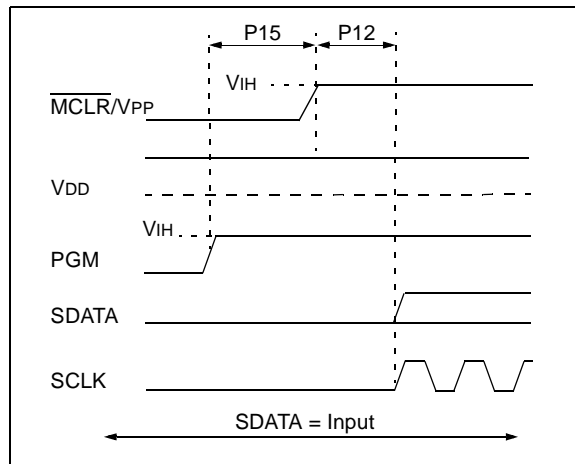

FIGURE 2-8: ENTERING LOW VOLTAGE PROGRAM/VERIFY MODE



PIC18F2331/2431/4331/4431

2.6 Serial Program/Verify Operation

The SCLK pin is used as a clock input pin and the SDATA pin is used for entering command bits and data input/output during serial operation. Commands and data are transmitted on the rising edge of SCLK, latched on the falling edge of SCLK, and are Least Significant bit (LSb) first.

2.6.1 4-BIT COMMANDS

All instructions are 20 bits, consisting of a leading 4-bit command followed by a 16-bit operand, which depends on the type of command being executed. To input a command, SCLK is cycled four times. The commands needed for programming and verification are shown in Table 2-3.

Depending on the 4-bit command, the 16-bit operand represents 16 bits of input data, or 8 bits of input data and 8 bits of output data.

Throughout this specification, commands and data are presented as illustrated in Table 2-4. The 4-bit command is shown MSb first. The command operand, or "Data Payload", is shown <MSb><LSb>. Figure 2-9 demonstrates how to serially present a 20-bit command/operand to the device.

2.6.2 CORE INSTRUCTION

The core instruction passes a 16-bit instruction to the CPU core for execution. This is needed to setup registers as appropriate for use with other commands.

TABLE 2-3: COMMANDS FOR PROGRAMMING

Description	4-Bit Command
Core Instruction (Shift in 16-bit instruction)	0000
Shift out TABLAT register	0010
Table Read	1000
Table Read, post-increment	1001
Table Read, post-decrement	1010
Table Read, pre-increment	1011
Table Write	1100
Table Write, post-increment by 2	1101
Table Write, post-decrement by 2	1110
Table Write, start programming	1111

TABLE 2-4: SAMPLE COMMAND SEQUENCE

4-Bit Command	Data Payload	Core Instruction
1101	3C 40	Table Write, post-increment by 2

FIGURE 2-9: TABLE WRITE, POST-INCREMENT TIMING (1101)

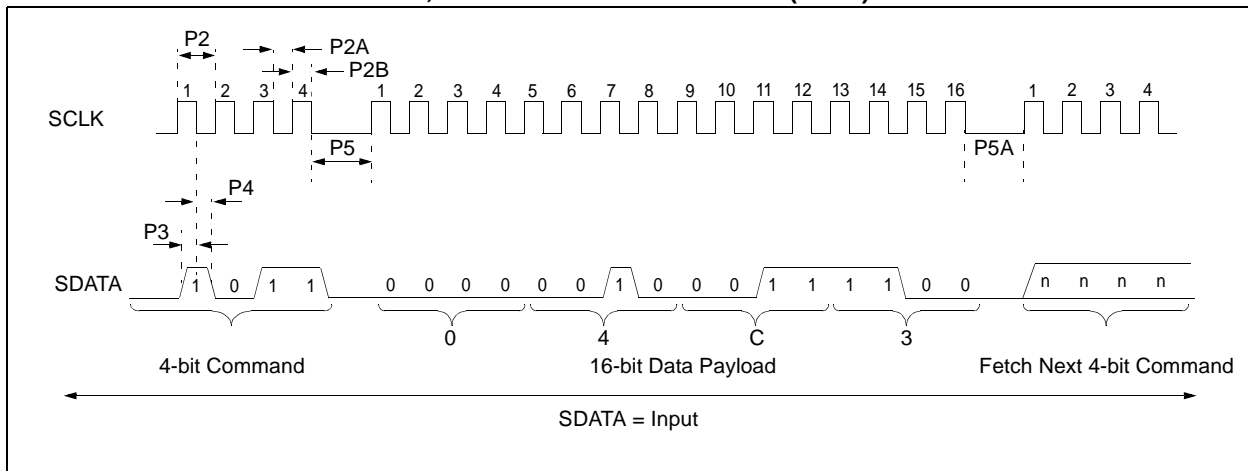

PIC18F2331/2431/4331/4431

3.0 DEVICE PROGRAMMING

3.1 High Voltage ICSP Bulk Erase

Erasing code or data EEPROM is accomplished by writing an “erase option” to address 3C0004h. Code memory may be erased portions at a time, or the user may erase the entire device in one action. “Bulk Erase” operations will also clear any code protect settings associated with the memory block erased. Erase options are detailed in Table 3-1.

TABLE 3-1: BULK ERASE OPTIONS

Description	Data
Chip Erase	80h
Erase Data EEPROM	81h
Erase Boot Block	83h
Erase Block 1	88h
Erase Block 2	89h
Erase Block 3	8Ah
Erase Block 4	8Bh

The actual bulk erase function is a self-timed operation. Once the erase has started (falling edge of the 4th SCLK after the NOP command), serial execution will cease until the erase completes (parameter P11). During this time, SCLK may continue to toggle but SDATA must be held low.

The code sequence to erase the entire device is shown in Table 3-2 and the flow chart is shown in Figure 3-1.

Note: A bulk erase is the only way to reprogram code protect bits from an on-state to an off-state. Non-code protect bits are not returned to default settings by a bulk erase. These bits should be programmed to ones, as outlined in Section 3.6, “Configuration Bits Programming”.

TABLE 3-2: BULK ERASE COMMAND SEQUENCE

4-Bit Command	Data Payload	Core Instruction
0000	0E 3C	MOVLW 3Ch
0000	6E F8	MOVWF TBLPTRU
0000	0E 00	MOVLW 00h
0000	6E F7	MOVWF TBLPTRH
0000	0E 04	MOVLW 04h
0000	6E F6	MOVWF TBLPTRL
1100	00 80	Write 80h TO 3C0004h to erase entire device.
0000	00 00	NOP
0000	00 00	Hold SDATA low until erase completes.

FIGURE 3-1: BULK ERASE FLOW

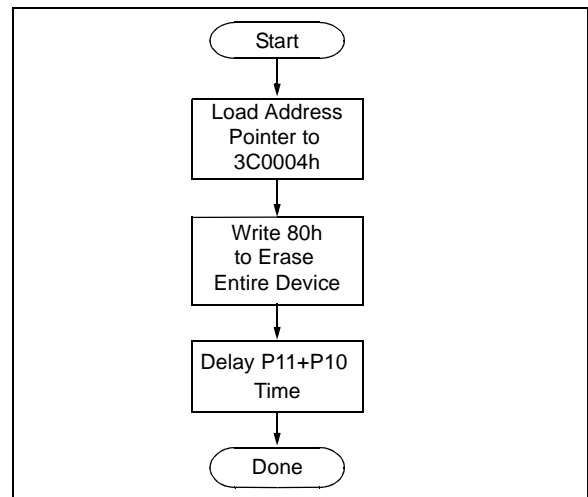
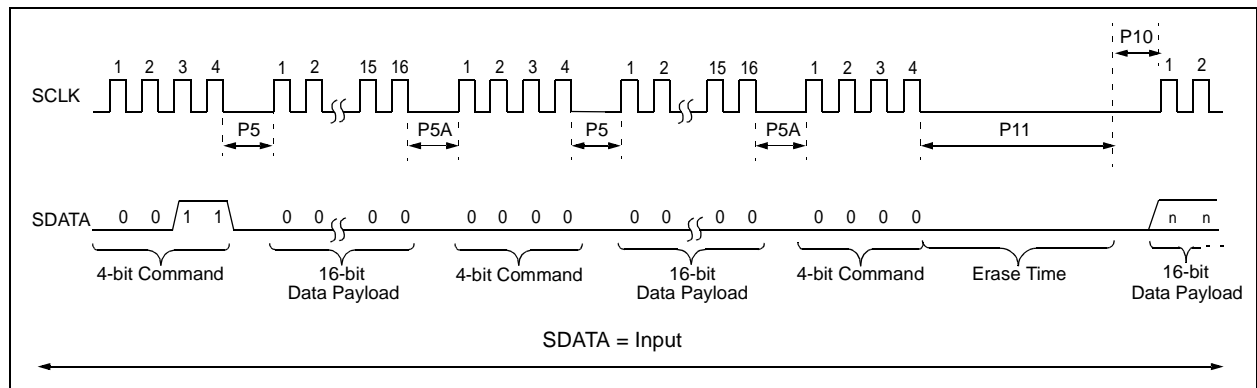

FIGURE 3-2: BULK ERASE TIMING



PIC18F2331/2431/4331/4431

3.1.1 LOW VOLTAGE ICSP BULK ERASE

When using low voltage ICSP, the part must be supplied by the voltage specified in parameter #D111 if a bulk erase is to be executed. All other bulk erase details as described above apply.

If it is determined that a program memory erase must be performed at a supply voltage below the bulk erase limit, refer to the erase methodology described in Sections 3.1.2 and 3.2.2.

If it is determined that a data EEPROM erase must be performed at a supply voltage below the bulk erase limit, follow the methodology described in Section 3.3 and write ones to the array.

3.1.2 ICSP MULTI-PANEL SINGLE ROW ERASE

Irrespective of whether high or low voltage ICSP is used, it is possible to erase single row (64 bytes of data) in all panels at once. For example, in the case of a 16-Kbyte device (4 panels), 512 bytes through 64 bytes in each panel can be erased simultaneously during each erase sequence. In this case, the offset of the erase within each panel is the same (see Figure 3-5). Multi-panel single row erase is enabled by appropriately configuring the Programming Control register located at 3C0006h.

The multi-panel single row erase duration is externally timed and is controlled by SCLK. After a “Start Programming” command is issued (4-bit, ‘1111’), a NOP is issued, where the 4th SCLK is held high for the duration of the programming time, P9.

After SCLK is brought low, the programming sequence is terminated. SCLK must be held low for the time specified by parameter P10 to allow high voltage discharge of the memory array.

The code sequence to program a PIC18FXX31 device is shown in Table 3-3. The flow chart shown in Figure 3-3 depicts the logic necessary to completely erase a PIC18FXX31 device. The timing diagram that details the “Start Programming” command, and parameters P9 and P10 is shown in Figure 3-6.

Note: The TBLPTR register must contain the same offset value when initiating the programming sequence as it did when the write buffers were loaded.
--

PIC18F2331/2431/4331/4431

TABLE 3-3: ERASE CODE MEMORY CODE SEQUENCE

4-Bit Command	Data Payload	Core Instruction
Step 1: Direct access to config memory.		
0000	8E A6	BSF EECON1, EEPGD
0000	8C A6	BSF EECON1, CFGS
0000	86 A6	BSF EECON1, WREN
Step 2: Configure device for multi-panel writes.		
0000	0E 3C	MOVLW 3Ch
0000	6E F8	MOVWF TBLPTRU
0000	0E 00	MOVLW 00h
0000	6E F7	MOVWF TBLPTRH
0000	0E 06	MOVLW 06h
0000	6E F6	MOVWF TBLPTRL
1100	00 40	Write 40h to 3C0006h to enable multi-panel erase.
Step 3: Direct access to code memory and enable erase.		
0000	8E A6	BSF EECON1, EEPGD
0000	9C A6	BCF EECON1, CFGS
0000	88 A6	BSF EECON1, FREE
0000	6A F8	CLRF TBLPTRU
0000	6A F7	CLRF TBLPTRH
0000	6A F6	CLRF TBLPTRL
Step 4: Erase single row of all panels at an offset.		
1111	<DummyLSB>	Write 2 dummy bytes and start programming.
	<DummyMSB>	
0000	00 00	NOP - hold SCLK high for time P9.
Step 5: Repeat step 4, with address pointer incremented by 64 until all panels are erased.		

FIGURE 3-3: MULTI-PANEL SINGLE ROW ERASE CODE MEMORY FLOW

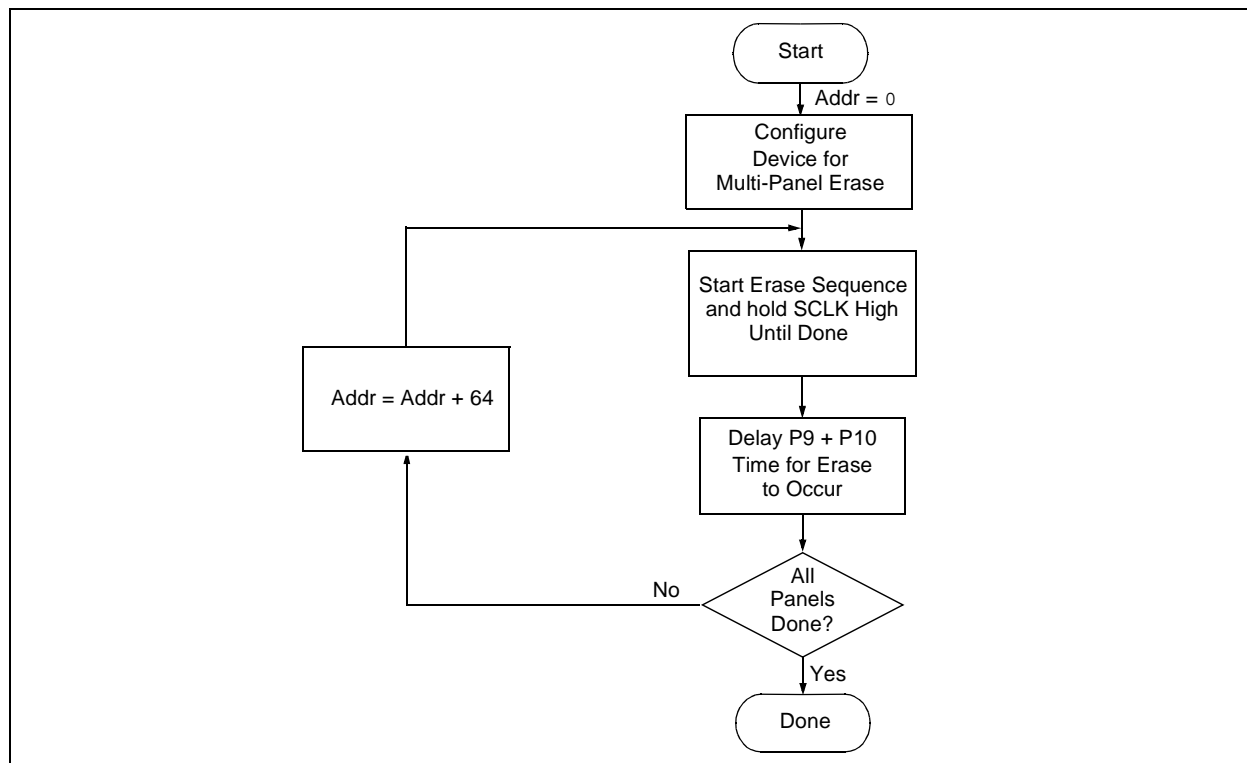

PIC18F2331/2431/4331/4431

3.2 Code Memory Programming

Programming code memory is accomplished by first loading data into the appropriate write buffers and then initiating a programming sequence. Each panel in the code memory space (see Figure 2-4) has an 8-byte deep write buffer that must be loaded prior to initiating a write sequence. The actual memory write sequence takes the contents of these buffers and programs the associated EEPROM code memory.

Typically, all of the program buffers are written in parallel (Multi-Panel Write mode). In other words, in the case of a 16-Kbyte device (2 panels with an 8-byte buffer per panel), 16 bytes will be simultaneously programmed during each programming sequence. In this case, the offset of the write within each panel is the same (see Figure 3-4). Multi-Panel Write mode is enabled by appropriately configuring the Programming Control register located at 3C0006h.

The programming duration is externally timed and is controlled by SCLK. After a “Start Programming” command is issued (4-bit command, ‘1111’), a NOP is issued, where the 4th SCLK is held high for the duration of the programming time, P9.

After SCLK is brought low, the programming sequence is terminated. SCLK must be held low for the time specified by parameter P10 to allow high voltage discharge of the memory array.

The code sequence to program a PIC18FXX31 device is shown in Table 3-4. The flow chart shown in Figure 3-5 depicts the logic necessary to completely write a PIC18FXX31 device. The timing diagram that details the “Start Programming” command, and parameters P9 and P10, is shown in Figure 3-6.

Note: The TBLPTR register must contain the same offset value when initiating the programming sequence as it did when the write buffers were loaded.

FIGURE 3-4: ERASE AND WRITE BOUNDARIES

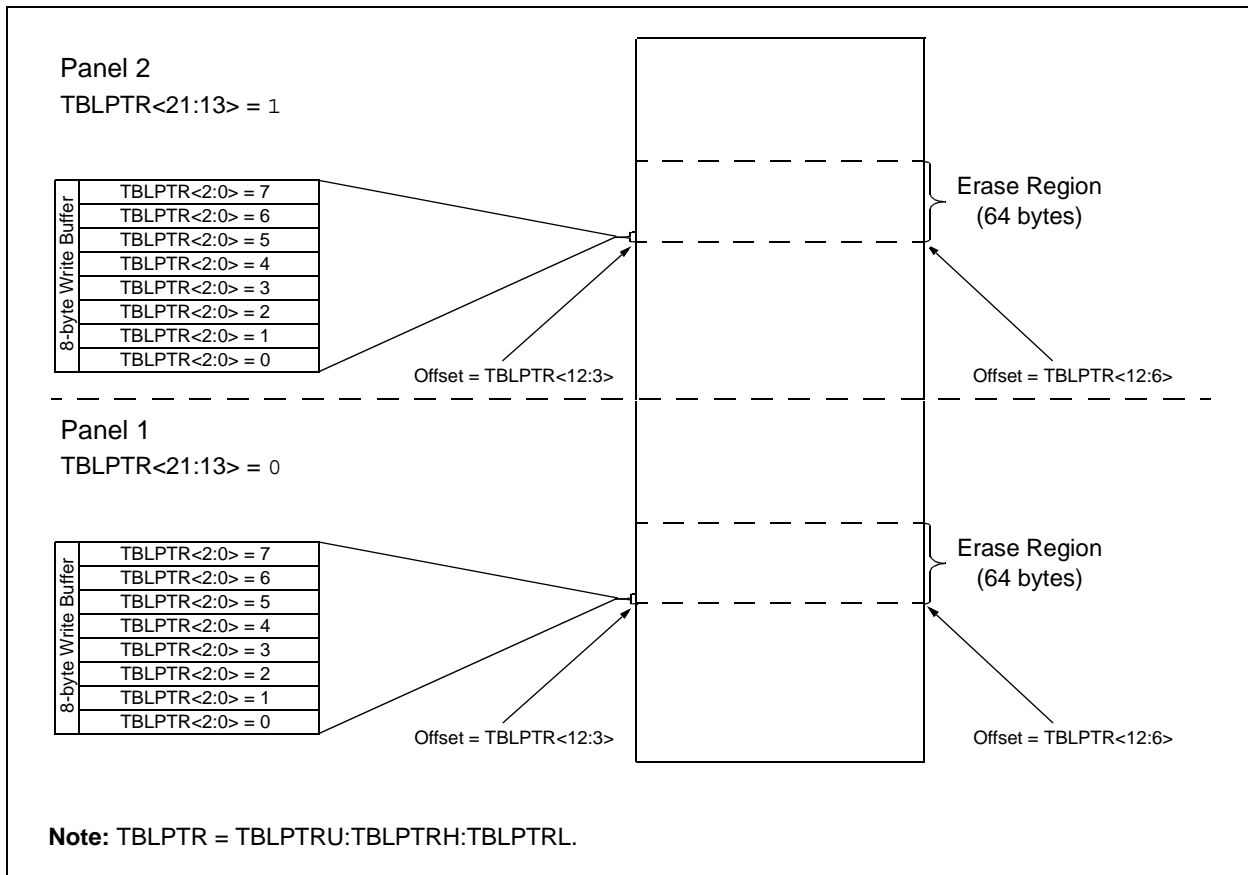

PIC18F2331/2431/4331/4431

TABLE 3-4: WRITE CODE MEMORY CODE SEQUENCE

4-Bit Command	Data Payload	Core Instruction
Step 1: Direct access to config memory.		
0000	8E A6	BSF EECON1, EEPGD
0000	8C A6	BSF EECON1, CFGS
0000	86 A6	BSF EECON1, WREN
Step 2: Configure device for multi-panel writes.		
0000	0E 3C	MOVLW 3Ch
0000	6E F8	MOVWF TBLPTRU
0000	0E 00	MOVLW 00h
0000	6E F7	MOVWF TBLPTRH
0000	0E 06	MOVLW 06h
0000	6E F6	MOVWF TBLPTRL
1100	00 40	Write 40h to 3C0006h to enable multi-panel writes.
Step 3: Direct access to code memory.		
0000	8E A6	BSF EECON1, EEPGD
0000	9C A6	BCF EECON1, CFGS
Step 4: Load write buffer for Panel 1.		
0000	0E <Addr[21:16]>	MOVLW <Addr[21:16]>
0000	6E F8	MOVWF TBLPTRU
0000	0E <Addr[15:8]>	MOVLW <Addr[15:8]>
0000	6E F7	MOVWF TBLPTRH
0000	0E <Addr[7:0]>	MOVLW <Addr[7:0]>
0000	6E F6	MOVWF TBLPTRL
1101	<LSB><MSB>	Write 2 bytes and post-increment address by 2
1101	<LSB><MSB>	Write 2 bytes and post-increment address by 2
1101	<LSB><MSB>	Write 2 bytes and post-increment address by 2
1100	<LSB><MSB>	Write 2 bytes
Step 5: Repeat for Panel 2.		
Step 6: Repeat for all but the last panel (N – 1).		
Step 7: Load write buffer for last panel.		
0000	0E <Addr[21:16]>	MOVLW <Addr[21:16]>
0000	6E F8	MOVWF TBLPTRU
0000	0E <Addr[15:8]>	MOVLW <Addr[15:8]>
0000	6E F7	MOVWF TBLPTRH
0000	0E <Addr[7:0]>	MOVLW <Addr[7:0]>
0000	6E F6	MOVWF TBLPTRL
1101	<LSB><MSB>	Write 2 bytes and post-increment address by 2
1101	<LSB><MSB>	Write 2 bytes and post-increment address by 2
1101	<LSB><MSB>	Write 2 bytes and post-increment address by 2
1111	<LSB><MSB>	Write 2 bytes and start programming
0000	00 00	NOP - hold SCLK high for time P9
To continue writing data, repeat steps 2 through 5, where the address pointer is incremented by 8 in each panel at each iteration of the loop.		

PIC18F2331/2431/4331/4431

FIGURE 3-5: PROGRAM CODE MEMORY FLOW

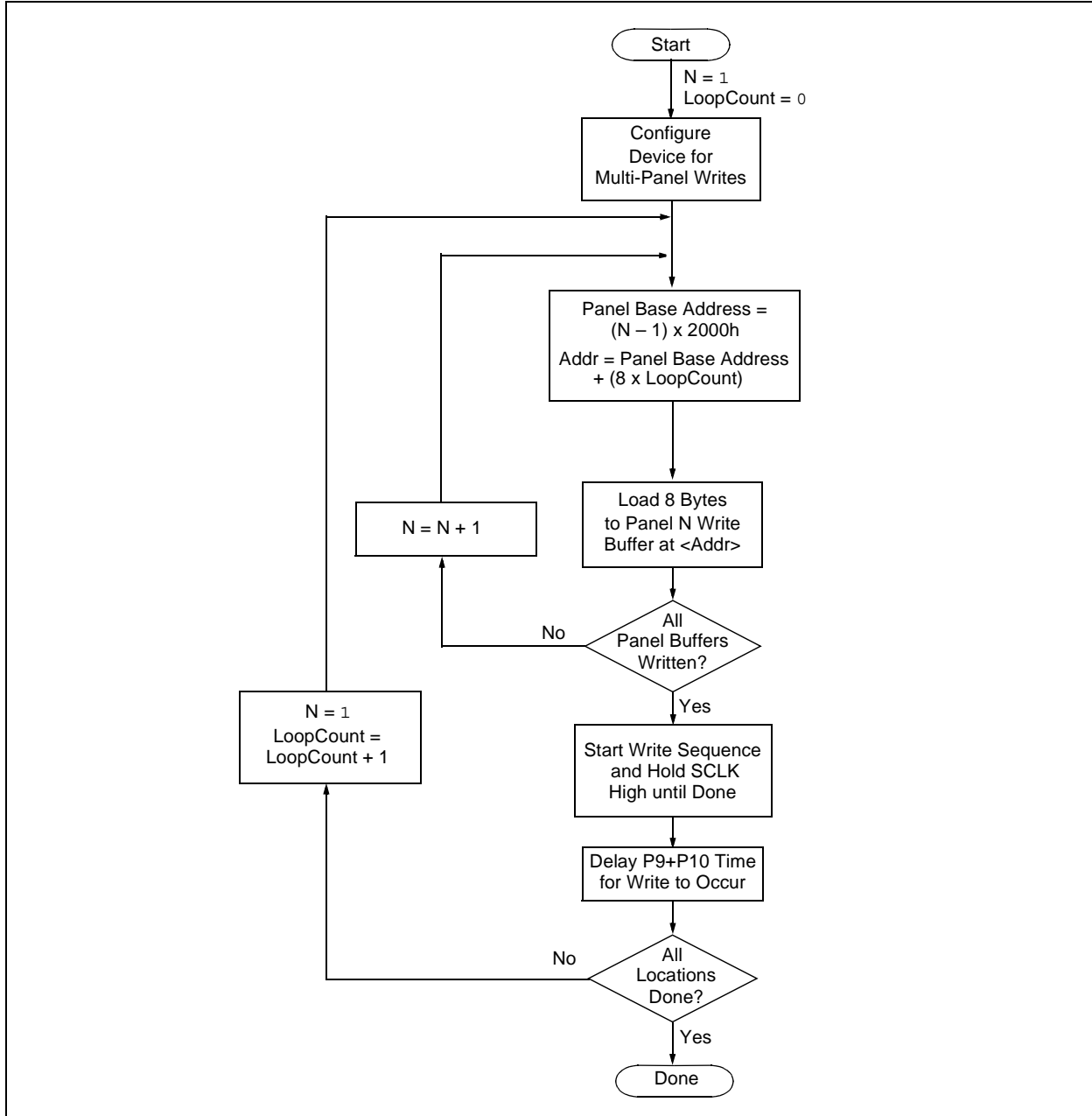
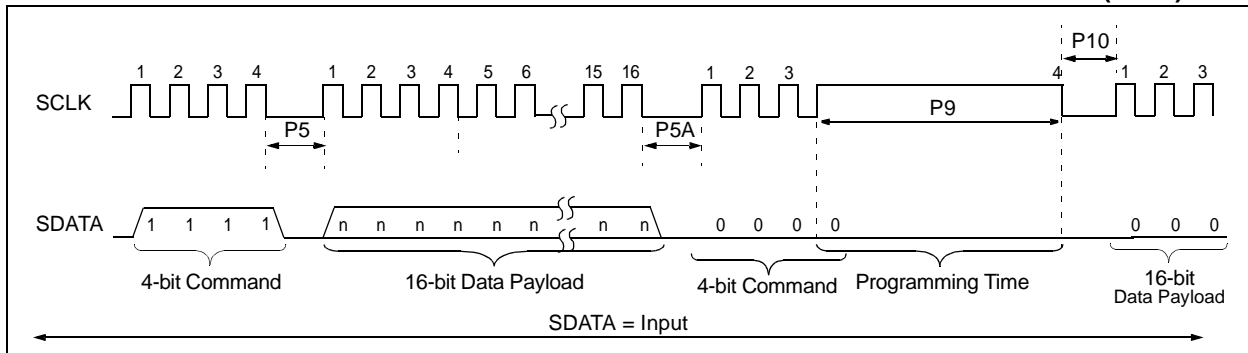

FIGURE 3-6: TABLE WRITE AND START PROGRAMMING INSTRUCTION TIMING (1111)



3.2.1 SINGLE PANEL PROGRAMMING

The programming example presented in Section 3.2 utilizes multi-panel programming. This technique greatly decreases the total amount of time necessary to completely program a device and is the recommended method of completely programming a device.

There may be situations, however, where it is advantageous to limit writes to a single panel. In such cases, the user only needs to disable the multi-panel write feature of the device by appropriately configuring the Programming Control register located at 3C0006h.

The single panel that will be written will automatically be enabled based on the value of the table pointer.

<p>Note: Even though multi-panel writes are disabled, the user must still fill the 8-byte write buffer for the given panel.</p>
--

3.2.2 MODIFYING CODE MEMORY

All of the programming examples up to this point have assumed that the device has been bulk erased prior to programming (see Section 3.1). It may be the case, however, that the user wishes to modify only a section of an already programmed device.

The minimum amount of data that can be written to the device is 8 bytes. This is accomplished by placing the device in Single Panel Write mode (see Section 3.2.1), loading the 8-byte write buffer for the panel, and then initiating a write sequence. In this case, however, it is assumed that the address space to be written already has data in it (i.e., it is not blank).

The minimum amount of code memory that may be erased at a given time is 64 bytes. Again, the device must be placed in Single Panel Write mode. The EECON1 register must then be used to erase the 64-byte target space prior to writing the data.

When using the EECON1 register to act on code memory, the EEPGD bit must be set (EECON1<7> = 1) and the CFGS bit must be cleared (EECON1<6> = 0). The WREN bit must be set (EECON1<2> = 1) to enable writes of any sort (e.g., erases), and this must be done prior to initiating a write sequence. The FREE bit must be set (EECON1<4> = 1) in order to erase the program space being pointed to by the table pointer. The erase sequence is initiated by the setting the WR bit (EECON1<1> = 1). It is strongly recommended that the WREN bit be set only when absolutely necessary.

To help prevent inadvertent writes when using the EECON1 register, EECON2 is used to “enable” the WR bit. This register must be sequentially loaded with 55h and then AAh, immediately prior to asserting the WR bit in order for the write to occur.

The erase will begin on the falling edge of the 4th SCLK after the WR bit is set. After the erase sequence terminates, SCLK must still be held low for the time specified by parameter #P10 to allow high voltage discharge of the memory array.

PIC18F2331/2431/4331/4431

TABLE 3-5: MODIFYING CODE MEMORY

4-Bit Command	Data Payload	Core Instruction
Step 1: Direct access to config memory.		
0000	8E A6	BSF EECON1, EEPGD
0000	8C A6	BSF EECON1, CFGS
Step 2: Configure device for single panel writes.		
0000	0E 3C	MOVLW 3Ch
0000	6E F8	MOVWF TBLPTRU
0000	0E 00	MOVLW 00h
0000	6E F7	MOVWF TBLPTRH
0000	0E 06	MOVLW 06h
0000	6E F6	MOVWF TBLPTRL
1100	00 00	Write 00h to 3C0006h to enable single panel writes.
Step 3: Direct access to code memory.		
0000	8E A6	BSF EECON1, EEPGD
0000	9C A6	BCF EECON1, CFGS
Step 4: Set the table pointer for the block to be erased.		
0000	0E <Addr [21:16]>	MOVLW <Addr [21:16]>
0000	6E F8	MOVWF TBLPTRU
0000	0E <Addr [8:15]>	MOVLW <Addr [8:15]>
0000	6E F7	MOVWF TBLPTRH
0000	0E <Addr [7:0]>	MOVLW <Addr [7:0]>
0000	6E F6	MOVWF TBLPTRL
Step 5: Enable memory writes and set up an erase.		
0000	84 A6	BSF EECON1, WREN
0000	88 A6	BSF EECON1, FREE
Step 6: Perform required sequence.		
0000	0E 55	MOVLW 55h
0000	6E A7	MOVWF EECON2
0000	0E AA	MOVLW 0AAh
0000	6E A7	MOVWF EECON2
Step 7: Initiate erase.		
0000	82 A6	BSF EECON1, WR
0000	00 00	NOP
Step 8: Wait for P11+P10 and then disable writes.		
0000	94 A6	BCF EECON1, WREN
Step 9: Load write buffer for panel. The correct panel will be selected based on the table pointer.		
0000	0E <Addr [8:15]>	MOVLW <Addr [8:15]>
0000	6E F7	MOVWF TBLPTRH
0000	0E <Addr [7:0]>	MOVLW <Addr [7:0]>
0000	6E F6	MOVWF TBLPTRL
1101	<LSB><MSB>	Write 2 bytes and post-increment address by 2
1101	<LSB><MSB>	Write 2 bytes and post-increment address by 2
1101	<LSB><MSB>	Write 2 bytes and post-increment address by 2
1111	<LSB><MSB>	Write 2 bytes and start programming
0000	00 00	NOP - hold SCLK high for time P9
To continue writing data, repeat step 8, where the address pointer is incremented by 8 at each iteration of the loop.		

3.3 Data EEPROM Programming

Data EEPROM is accessed one byte at a time via an address pointer (register pair EEADR:EEADRH) and a data latch (EEDATA). Data EEPROM is written by loading EEADR:EEADRH with the desired memory location, EEDATA with the data to be written, and initiating a memory write by appropriately configuring the EECON1 and EECON2 registers. A byte write automatically erases the location and writes the new data (erase-before-write).

When using the EECON1 register to perform a data EEPROM write, both the EEPGD and CFGS bits must be cleared (EECON1<7:6> = 00). The WREN bit must be set (EECON1<2> = 1) to enable writes of any sort, and this must be done prior to initiating a write sequence. The write sequence is initiated by setting the WR bit (EECON1<1> = 1). It is strongly recommended that the WREN bit be set only when absolutely necessary.

To help prevent inadvertent writes when using the EECON1 register, EECON2 is used to "enable" the WR bit. This register must be sequentially loaded with 55h and then AAh, immediately prior to asserting the WR bit in order for the write to occur.

The write begins on the falling edge of the 4th SCLK after the WR bit is set. It ends when the WR bit is cleared by hardware.

After the programming sequence terminates, SCLK must still be held low for the time specified by parameter P10 to allow high voltage discharge of the memory array.

FIGURE 3-7: PROGRAM DATA FLOW

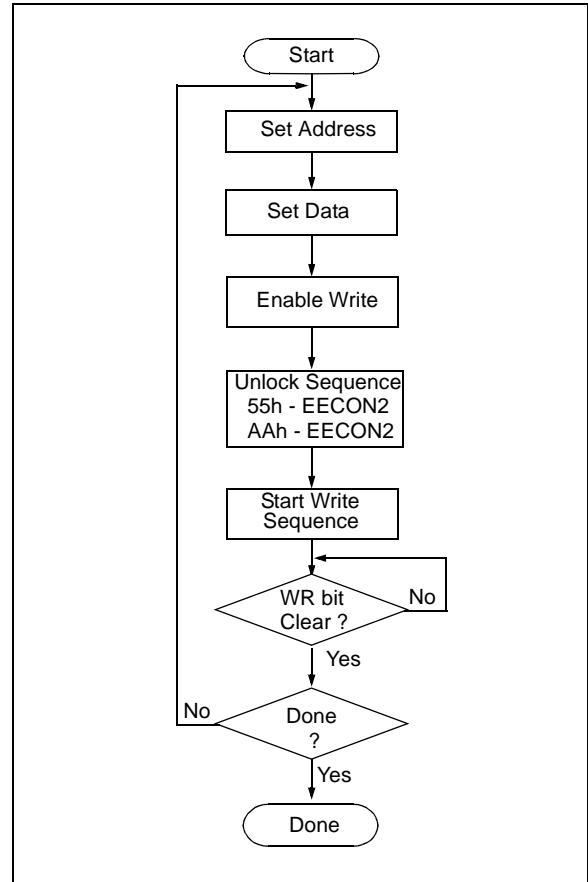
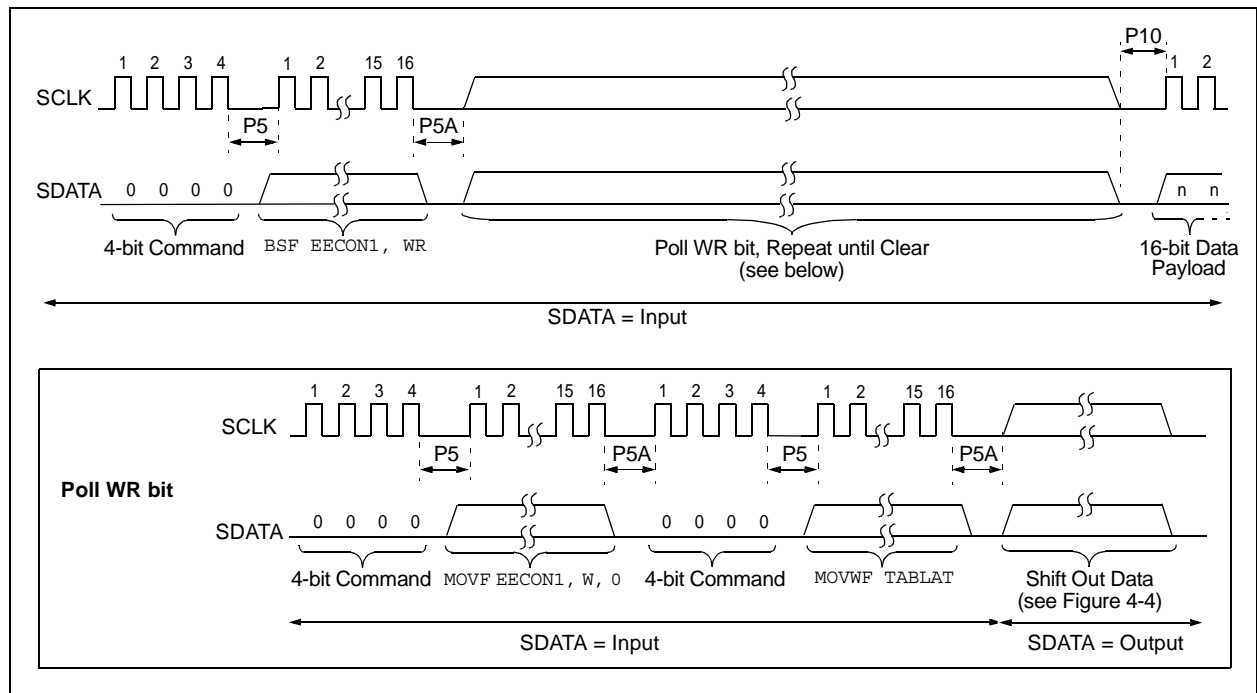

FIGURE 3-8: DATA EEPROM WRITE TIMING



PIC18F2331/2431/4331/4431

TABLE 3-6: PROGRAMMING DATA MEMORY

4-Bit Command	Data Payload	Core Instruction
Step 1: Direct access to data EEPROM.		
0000	9E A6	BCF EECON1, EEPGD
0000	9C A6	BCF EECON1, CFGS
Step 2: Set the data EEPROM address pointer.		
0000	0E <Addr>	MOVLW <Addr>
0000	6E A9	MOVWF EEADR
0000	0E <AddrH>	MOVLW <AddrH>
0000	6E AA	MOVWF EEADRH
Step 3: Load the data to be written.		
0000	0E <Data>	MOVLW <Data>
0000	6E A8	MOVWF EEDATA
Step 4: Enable memory writes.		
0000	84 A6	BSF EECON1, WREN
Step 5: Perform required sequence.		
0000	0E 55	MOVLW 0X55
0000	6E A7	MOVWF EECON2
0000	0E AA	MOVLW 0XAA
0000	6E A7	MOVWF EECON2
Step 6: Initiate write.		
0000	82 A6	BSF EECON1, WR
Step 7: Poll WR bit, repeat until the bit is clear.		
0000	50 A6	MOVF EECON1, W, 0
0000	6E F5	MOVWF TABLAT
0010	<LSB><MSB>	Shift out data ⁽¹⁾
Step 8: Disable writes.		
0000	94 A6	BCF EECON1, WREN
Repeat steps 2 through 8 to write more data.		

Note 1: See Figure 4-4 for details on shift out data timing.

PIC18F2331/2431/4331/4431

3.4 ID Location Programming

The ID locations are programmed much like the code memory except that multi-panel writes must be disabled. The single panel that will be written will automatically be enabled based on the value of the table pointer. The ID registers are mapped in addresses 200000h through 200007h. These locations read out normally even after code protection.

Note: Even though multi-panel writes are disabled, the user must still fill the 8-byte data buffer for the panel.

Table 3-7 demonstrates the code sequence required to write the ID locations.

TABLE 3-7: WRITE ID SEQUENCE

4-Bit Command	Data Payload	Core Instruction
Step 1: Direct access to config memory.		
0000	8E A6	BSF EECON1, EEPGD
0000	8C A6	BSF EECON1, CFGS
Step 2: Configure device for single panel writes.		
0000	0E 3C	MOVLW 3Ch
0000	6E F8	MOVWF TBLPTRU
0000	0E 00	MOVLW 00h
0000	6E F7	MOVWF TBLPTRH
0000	0E 06	MOVLW 06h
0000	6E F6	MOVWF TBLPTRL
1100	00 00	Write 00h to 3C0006h to enable single panel writes.
Step 3: Direct access to code memory.		
0000	8E A6	BSF EECON1, EEPGD
0000	9C A6	BCF EECON1, CFGS
Step 4: Load write buffer. Panel will be automatically determined by address.		
0000	0E 20	MOVLW 20h
0000	6E F8	MOVWF TBLPTRU
0000	0E 00	MOVLW 00h
0000	6E F7	MOVWF TBLPTRH
0000	0E 00	MOVLW 00h
0000	6E F6	MOVWF TBLPTRL
1101	<LSB><MSB>	Write 2 bytes and post-increment address by 2
1101	<LSB><MSB>	Write 2 bytes and post-increment address by 2
1101	<LSB><MSB>	Write 2 bytes and post-increment address by 2
1111	<LSB><MSB>	Write 2 bytes and start programming
0000	00 00	NOP - hold SCLK high for time P9

In order to modify the ID locations, refer to the methodology described in Section 3.2.2, "Modifying Code Memory". As with code memory, the ID locations must be erased before modified.

PIC18F2331/2431/4331/4431

3.5 Boot Block Programming

The boot block segment is programmed in exactly the same manner as the ID locations (see Section 3.4). Multi-panel writes must be disabled so that only addresses in the range 0000h to 01FFh will be written.

The code sequence detailed in Table 3-7 should be used, except that the address data used in “Step 2” will be in the range 000000h to 0001FFh.

3.6 Configuration Bits Programming

Unlike code memory, the configuration bits are programmed a byte at a time. The “Table Write, Begin Programming” 4-bit command (1111) is used but only 8 bits of the following 16-bit payload will be written. The LSB of the payload will be written to even addresses, and the MSB will be written to odd addresses. The code sequence to program two consecutive configuration locations is shown in Table 3-8.

TABLE 3-8: SET ADDRESS POINTER TO CONFIGURATION LOCATION

4-Bit Command	Data Payload	Core Instruction
Step 1: Direct access to config memory.		
0000	8E A6	BSF EECON1, EEPGD
0000	8C A6	BSF EECON1, CFGS
Step 2: Position the program counter ⁽¹⁾ .		
0000	EF 00	GOTO 100000h
0000	F8 00	
Step 3 ⁽²⁾ : Set table pointer for config byte to be written. Write even/odd addresses.		
0000	0E 30	MOVLW 30h
0000	6E F8	MOVWF TBLPTRU
0000	0E 00	MOVLW 00h
0000	6E F7	MOVWF TBLPRTH
0000	0E 00	MOVLW 00h
0000	6E F6	MOVWF TBLPTRL
1111	<LSB><MSB ignored>	Load 2 bytes and start programming
0000	00 00	NOP - hold SCLK high for time P9
0000	2A F6	INCF TBLPTRL
1111	<LSB ignored><MSB>	Load 2 bytes and start programming
0000	00 00	NOP - hold SCLK high for time P9

- Note 1:** If the code protection bits are programmed while the program counter resides in the same block, then the interaction of code protection logic may prevent further table write. To avoid this situation, move the program counter outside the code protection area (e.g., GOTO 100000h).
- Note 2:** Enabling the write protection of configuration bits (WRTC = 0 in CONFIG6H) will prevent further writing of configuration bits. Always write all the configuration bits before enabling the write protection for configuration bits.

FIGURE 3-9: CONFIGURATION PROGRAMMING FLOW

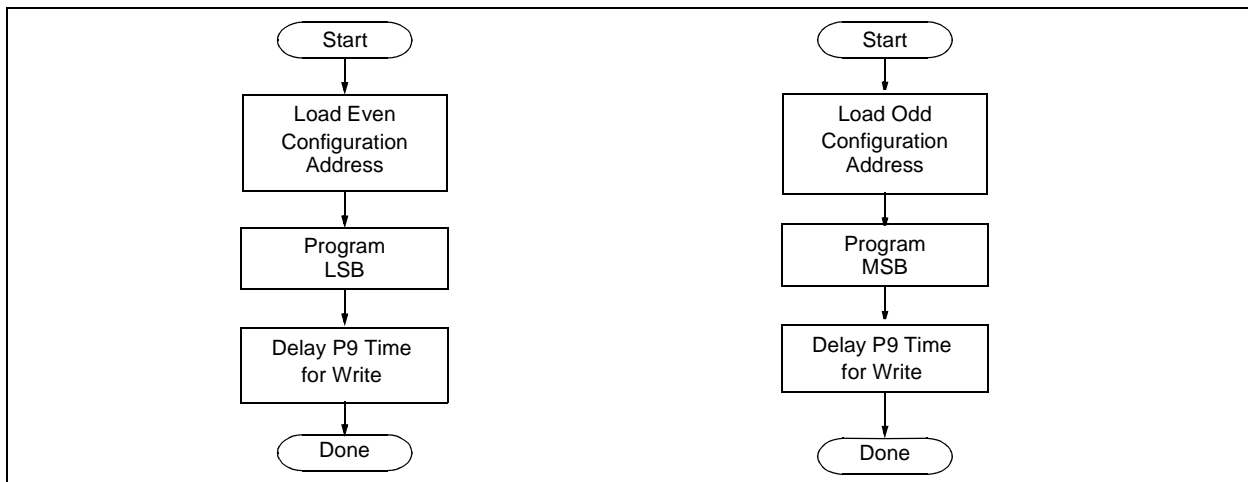

PIC18F2331/2431/4331/4431

4.0 READING THE DEVICE

4.1 Read Code Memory, ID Locations, and Configuration Bits

Code memory is accessed one byte at a time via the 4-bit command, '1001' (table read, post-increment). The contents of memory pointed to by the table pointer (TBLPTRU:TBLPTRH:TBLPTRL) are loaded into the table latch and then serially output on SDATA.

The 4-bit command is shifted in LSb first. The table read is executed during the next 8 clocks, then shifted out on SDATA during the last 8 clocks, LSb to MSb. A delay of P6 must be introduced after the falling edge of the 8th SCLK of the operand to allow SDATA to transition from an input to an output. During this time, SCLK must be held low (see Figure 4-1). This operation also increments the table pointer by one, pointing to the next byte in code memory for the next read.

This technique will work to read any memory in the 000000h to 3FFFFFFh address space, so it also applies to the reading of the ID and Configuration registers.

TABLE 4-1: READ CODE MEMORY SEQUENCE

4-Bit Command	Data Payload	Core Instruction
Step 1: Set table pointer.		
0000	0E <Addr [21:16] >	MOVLW Addr [21:16]
0000	6E F8	MOVWF TBLPTRU
0000	0E <Addr [15:8] >	MOVLW <Addr [15:8] >
0000	6E F7	MOVWF TBLPTRH
0000	0E <Addr [7:0] >	MOVLW <Addr [7:0] >
0000	6E F6	MOVWF TBLPTRL
Step 2: Read memory into table latch and then shift out on SDATA, LSb to MSb.		
1001	00 00	TBLRD *+

FIGURE 4-1: TABLE READ POST-INCREMENT INSTRUCTION TIMING (1001)

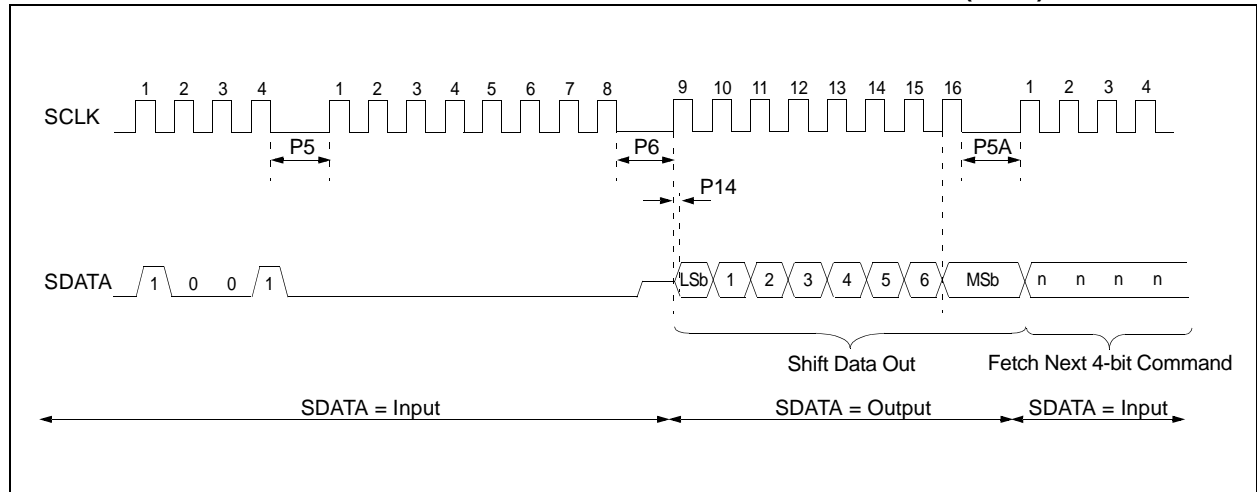

PIC18F2331/2431/4331/4431

4.2 Verify Code Memory and ID Locations

The verify step involves reading back the code memory space and comparing against the copy held in the programmer's buffer. Memory reads occur a single byte at a time, so two bytes must be read to compare against the word in the programmer's buffer. Refer to Section 4.1 for implementation details of reading code memory.

The table pointer must be manually set to 200000h (base address of the ID locations) once the code memory has been verified. The post-increment feature of the table read 4-bit command may not be used to increment the table pointer beyond the code memory space. In a 16-Kbyte device, for example, a post-increment read of address 3FFFh will wrap the table pointer back to 0000h, rather than point to unimplemented address 4000h.

FIGURE 4-2: VERIFY CODE MEMORY FLOW

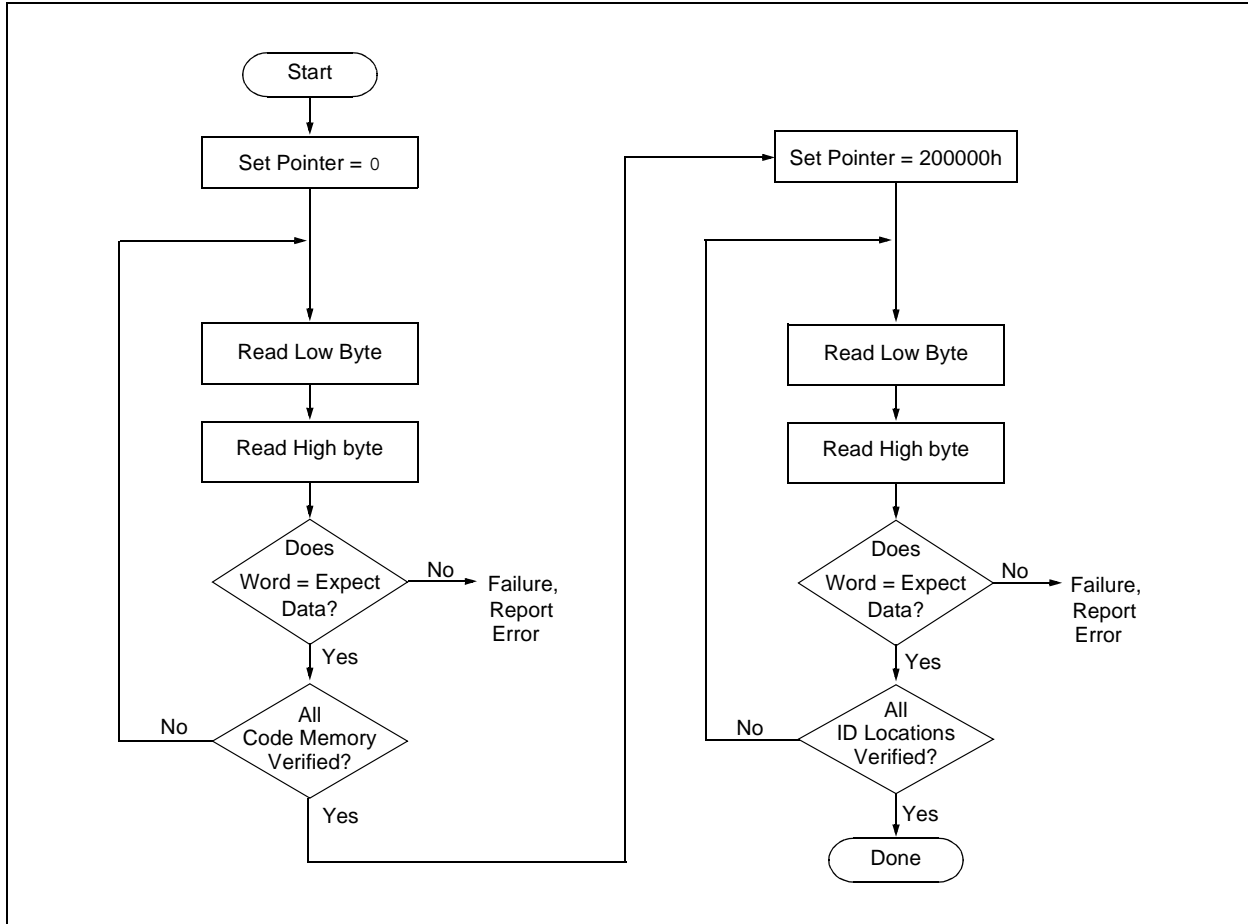

4.3 Verify Configuration Bits

A configuration address may be read and output on SDATA via the 4-bit command, '1001'. Configuration data is read and written in a byte-wise fashion, so it is not necessary to merge two bytes into a word prior to a compare. The result may then be immediately compared to the appropriate configuration data in the programmer's memory for verification. Refer to Section 4.1 for implementation details of reading configuration data.

4.4 Read Data EEPROM Memory

Data EEPROM is accessed one byte at a time via an address pointer (register pair EEADR:EEADRH) and a data latch (EEDATA). Data EEPROM is read by loading EEADR:EEADRH with the desired memory location and initiating a memory read by appropriately configuring the EECON1 register. The data will be loaded into EEDATA, where it may be serially output on SDATA via the 4-bit command, '0010' (Shift Out Data Holding register). A delay of P6 must be introduced after the falling edge of the 8th SCLK of the operand to allow SDATA to transition from an input to an output. During this time, SCLK must be held low (see Figure 4-4).

The command sequence to read a single byte of data is shown in Table 4-2.

FIGURE 4-3: READ DATA EEPROM FLOW

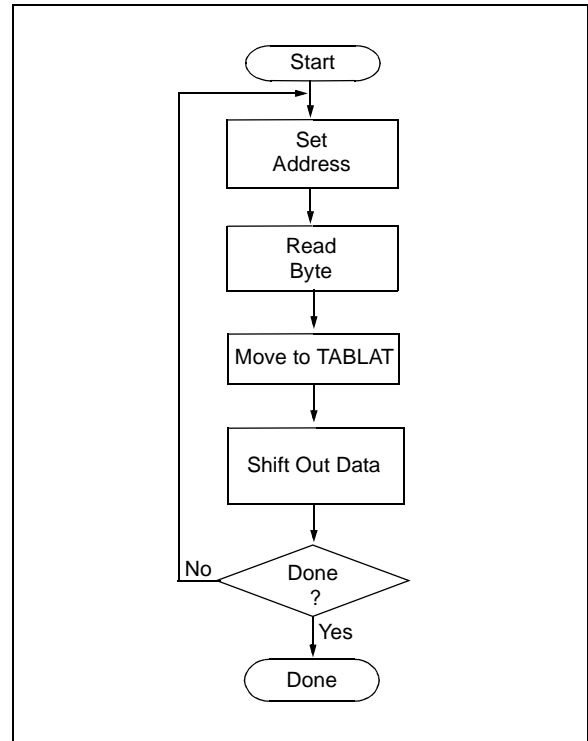

PIC18F2331/2431/4331/4431

TABLE 4-2: READ DATA EEPROM MEMORY

4-Bit Command	Data Payload	Core Instruction
Step 1: Direct access to data EEPROM.		
0000	9E A6	BCF EECON1, EEPGD
0000	9C A6	BCF EECON1, CFGS
Step 2: Set the data EEPROM address pointer.		
0000	0E <Addr>	MOVLW <Addr>
0000	6E A9	MOVWF EEADR
0000	0E <AddrH>	MOVLW <AddrH>
0000	6E AA	MOVWF EEADRH
Step 3: Initiate a memory read.		
0000	80 A6	BSF EECON1, RD
Step 4: Load data into the Serial Data Holding register.		
0000	50 A8	MOVF EEDATA, W, 0
0000	6E F5	MOVWF TABLAT
0010	<LSB><MSB>	Shift Out Data ⁽¹⁾

Note 1: The <LSB> is undefined. The <MSB> is the data.

FIGURE 4-4: SHIFT OUT DATA HOLDING REGISTER TIMING (0010)

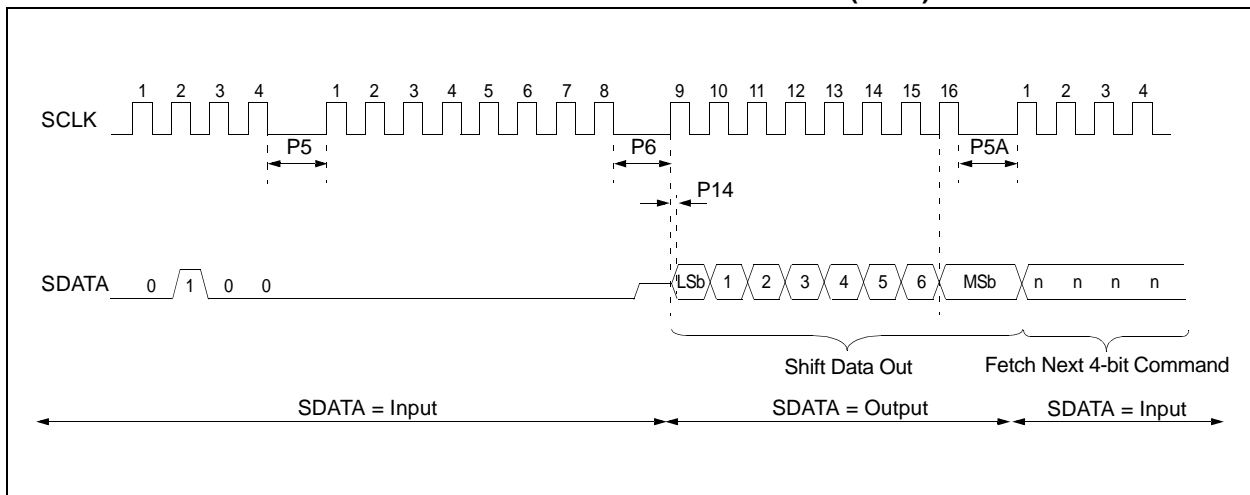

4.5 Verify Data EEPROM

A data EEPROM address may be read via a sequence of core instructions (4-bit command, '0000') and then output on SDATA via the 4-bit command, '0010' (Shift Out Data Holding register). The result may then be immediately compared to the appropriate data in the programmer's memory for verification. Refer to Section 4.4 for implementation details of reading data EEPROM.

4.6 Blank Check

The term "Blank Check" means to verify that the device has no programmed memory cells. All memories must be verified: code memory, data EEPROM, ID locations, and configuration bits. The Device ID registers (3FFFFEh:3FFFFFFh) should be ignored.

A "blank" or "erased" memory cell will read as a '1'. So, "Blank Checking" a device merely means to verify that all bytes read as FFh except the configuration bits. Unused (reserved) configuration bits will read '0' (programmed). Refer to Table 5-2 and Table 5-3 for blank configuration expect data for the various PIC18FXX31 devices.

Given that "Blank Checking" is merely code and data EEPROM verification with FFh expect data, refer to Section 4.4 and Section 4.2 for implementation details.

FIGURE 4-5: BLANK CHECK FLOW

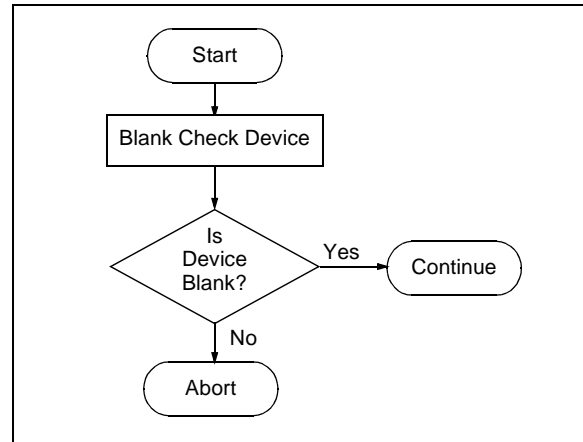

PIC18F2331/2431/4331/4431

5.0 CONFIGURATION WORD

The PIC18FXX31 devices have several configuration words. These bits can be set or cleared to select various device configurations. All other memory areas should be programmed and verified prior to setting configuration words. These bits may be read out normally even after read or code protection.

5.1 ID Locations

A user may store identification information (ID) in eight ID locations mapped in 200000h:200007h. It is recommended that the Most Significant nibble of each ID be 0Fh. In doing so, if the user code inadvertently tries to execute from the ID space, the ID data will execute as NOP.

5.2 Device ID Word

The device ID word for the PIC18FXX31 is located at 3FFFFEh:3FFFFFh. These bits may be used by the programmer to identify what device type is being programmed and read out normally even after code or read protection.

5.3 Low Voltage Programming (LVP) Bit

The LVP bit in Configuration register, CONFIG4L, enables low voltage ICSP programming. The LVP bit defaults to a '1' from the factory.

If Low Voltage Programming mode is not used, the LVP bit can be programmed to a '0' and RB5/PGM becomes a digital I/O pin. However, the LVP bit may only be programmed by entering the High Voltage ICSP mode, where $\overline{\text{MCLR}}/\text{VPP}$ is raised to V_{IH} . Once the LVP bit is programmed to a '0', only the High Voltage ICSP mode is available and only the High Voltage ICSP mode can be used to program the device.

Note 1: The normal ICSP mode is always available, regardless of the state of the LVP bit, by applying V_{IH} to the $\overline{\text{MCLR}}/\text{VPP}$ pin.

2: While in Low Voltage ICSP mode, the RB5 pin can no longer be used as a general purpose I/O.

TABLE 5-1: DEVICE ID VALUES

Device	Device ID Value	
	DEVID2	DEVID1
PIC18F2331	08h	E0h
PIC18F2431	08h	C0h
PIC18F4331	08h	A0h
PIC18F4431	08h	80h

Note: The 'x's in DEVID1 contain the device revision code.

PIC18F2331/2431/4331/4431

TABLE 5-2: PIC18FX431 CONFIGURATION BITS AND DEVICE IDS

File Name		Bit 7	Bit 6	Bit 5	Bit 4	Bit 3	Bit 2	Bit 1	Bit 0	Default/ Unprogrammed Value
300001h	CONFIG1H	IESO	FCMEM	—	—	Fosc3	Fosc2	Fosc1	Fosc0	1100 1111
300002h	CONFIG2L	—	—	—	—	BORV1	BORV0	BODEN	PWR $\overline{\text{TEN}}$	0000 1111
300003h	CONFIG2H	—	—	WINEN	WDPS3	WDTPS2	WDTPS1	WDTPS0	WDTEN	0011 1111
300004h	CONFIG3L	—	—	$\overline{\text{T5REN}}$	HPOL	LPOL	PWMPIN	—	—	0011 1100
300005h	CONFIG3H	MCLRE	—	—	EXCLKMX	PWM4MX	SSPMX	—	FLTAMX	1001 1101
300006h	CONFIG4L	$\overline{\text{DEBUG}}$	—	—	—	—	LVP	—	STVREN	1000 0101
300008h	CONFIG5L	—	—	—	—	CP3	CP2	CP1	CP0	0000 1111
300009h	CONFIG5H	CPD	CPB	—	—	—	—	—	—	1100 0000
30000Ah	CONFIG6L	—	—	—	—	WRT3	WRT2	WRT1	WRT0	0000 1111
30000Bh	CONFIG6H	WRTD	WRTB	WRTC	—	—	—	—	—	1110 0000
30000Ch	CONFIG7L	—	—	—	—	EBTR3	EBTR2	EBTR1	EBTR0	0000 1111
30000Dh	CONFIG7H	—	EBTRB	—	—	—	—	—	—	0100 0000
3FFFEh	DEVID1	DEV2	DEV1	DEV0	REV4	REV3	REV2	REV1	REV0	Table 5-1
3FFFFh	DEVID2	DEV10	DEV9	DEV8	DEV7	DEV6	DEV5	DEV4	DEV3	Table 5-1

Legend: x = unknown, u = unchanged, - = unimplemented, q = value depends on condition.
Shaded cells are unimplemented, read as '0'.

TABLE 5-3: PIC18FX331 CONFIGURATION BITS AND DEVICE IDS

File Name		Bit 7	Bit 6	Bit 5	Bit 4	Bit 3	Bit 2	Bit 1	Bit 0	Default/ Unprogrammed Value
300001h	CONFIG1H	IESO	FCMEM	—	—	Fosc3	Fosc2	Fosc1	Fosc0	1100 1111
300002h	CONFIG2L	—	—	—	—	BORV1	BORV0	BODEN	PWR $\overline{\text{TEN}}$	0000 1111
300003h	CONFIG2H	—	—	WINEN	WDPS3	WDTPS2	WDTPS1	WDTPS0	WDTEN	0011 1111
300004h	CONFIG3L	—	—	$\overline{\text{T5REN}}$	HPOL	LPOL	PWMPIN	—	—	0011 1100
300005h	CONFIG3H	MCLRE	—	—	EXCLKMX	PWM4MX	SSPMX	—	FLTAMX	1001 1101
300006h	CONFIG4L	$\overline{\text{DEBUG}}$	—	—	—	—	LVP	—	STVREN	1000 0101
300008h	CONFIG5L	—	—	—	—	—	—	CP1	CP0	0000 0011
300009h	CONFIG5H	CPD	CPB	—	—	—	—	—	—	1100 0000
30000Ah	CONFIG6L	—	—	—	—	—	—	WRT1	WRT0	0000 0011
30000Bh	CONFIG6H	WRTD	WRTB	WRTC	—	—	—	—	—	1110 0000
30000Ch	CONFIG7L	—	—	—	—	—	—	EBTR1	EBTR0	0000 0011
30000Dh	CONFIG7H	—	EBTRB	—	—	—	—	—	—	0100 0000
3FFFEh	DEVID1	DEV2	DEV1	DEV0	REV4	REV3	REV2	REV1	REV0	Table 5-1
3FFFFh	DEVID2	DEV10	DEV9	DEV8	DEV7	DEV6	DEV5	DEV4	DEV3	Table 5-1

Legend: x = unknown, u = unchanged, - = unimplemented, q = value depends on condition.
Shaded cells are unimplemented, read as '0'.

PIC18F2331/2431/4331/4431

TABLE 5-4: PIC18FXX31 CONFIGURATION BIT DESCRIPTIONS

Bit Name	Configuration Words	Description
IESO	CONFIG1H	Internal External Switch Over bit 1 = Internal External Switch Over mode enabled 0 = Internal External Switch Over mode disabled
FCMEN	CONFIG1H	Fail-Safe Clock Monitor Enable bit 1 = Fail-Safe Clock Monitor enabled 0 = Fail-Safe Clock Monitor disabled
FOSC<3:0>	CONFIG1H	Oscillator Selection bits 11xx = External RC oscillator, CLKO function on RA6 101x = External RC oscillator, CLKO function on RA6 1001 = Internal RC oscillator, CLKO function on RA6, and port function on RA7 1000 = Internal RC oscillator, port function on RA6, and port function on RA7 0111 = External RC oscillator, port function on RA6 0110 = HS oscillator, PLL enabled (clock frequency = 4 x FOSC1) 0101 = EC oscillator, port function on RA6 0100 = EC oscillator, CLKO function on RA6 0011 = External RC oscillator, CLKO function on RA6 0010 = HS oscillator 0001 = XT oscillator 0000 = LP oscillator
BORV<1:0>	CONFIG2L	Brown-out Reset Voltage bits 11 = VBOR set to 2.0V 10 = VBOR set to 2.7V 01 = VBOR set to 4.2V 00 = VBOR set to 4.5V
BOREN	CONFIG2L	Brown-out Reset Enable bit 1 = Brown-out Reset enabled 0 = Disabled
PWRTEN	CONFIG2L	Power-up Timer Enable bit 1 = PWRT disabled 0 = Enabled

- Note 1:** Polarity control bits HPOL and LPOL define PWM signal output active and inactive states, PWM states generated by the fault inputs or PWM manual override.
- 2:** PWM6 and PWM7 output channels are only available on the PIC18F4X21 devices.
- 3:** When PWMPIN = 0, PWMEN<2:0> = 101 if device has eight PWM output pins (40 and 44-pin devices) and PWMEN<2:0> = 100 if the device has six PWM output pins (28-pin device). PWM output polarity is defined by HPOL and LPOL.
- 4:** This bit is reserved on PIC18F2X31 devices and should be maintained set (i.e., equal to '1').
- 5:** For PIC18FX431 devices only.

PIC18F2331/2431/4331/4431

TABLE 5-4: PIC18FXX31 CONFIGURATION BIT DESCRIPTIONS (CONTINUED)

Bit Name	Configuration Words	Description
WINEN	CONFIG2H	Watchdog Timer Window Enable bit 1 = Enable window comparison 0 = Disable window comparison
WDPS<3:0>	CONFIG2H	Watchdog Timer Postscale Select bits 1111 = 1:32,768 1110 = 1:16,384 1101 = 1:8,192 1100 = 1:4,096 1011 = 1:2,048 1010 = 1:1,024 1001 = 1:512 1000 = 1:256 0111 = 1:128 0110 = 1:64 0101 = 1:32 0100 = 1:16 0011 = 1:8 0010 = 1:4 0001 = 1:2 0000 = 1:1
WDTEN	CONFIG2H	Watchdog Timer Enable bit 1 = WDT enabled 0 = WDT disabled (control is placed on the SWDTEN bit in WDTCON register)
GPTREN	CONFIG3L	GPT Reset upon CAP1 Special Event Trigger bit 1 = Special Event Reset enable (<u>RESEN</u> in TMR5CON register) is inactive. 0 = Special Event Reset enable (<u>RESEN</u> in TMR5CON register) is active and can enable the special event trigger signal from IC1 to reset the TMR5 time base.
HPOL ⁽¹⁾	CONFIG3L	High Side Transistors Polarity bit (i.e., Odd PWM Output Polarity Control bit) 1 = PWM 1, 3, 5, and 7 are active high (default) 0 = PWM 1, 3, 5, and 7 are active low
LPOL ⁽¹⁾	CONFIG3L	Low Side Transistors Polarity bit (i.e., Even PWM Output Polarity Control bit) 1 = PWM 0, 2, 4, and 6 are active high (default) 0 = PWM 0, 2, 4, and 6 are active low
PWMPIN ⁽²⁾	CONFIG3L	PWM Output Pins RESET State Control bit 1 = PWM outputs disabled upon RESET (default) 0 = PWM outputs drive active states upon RESET ⁽³⁾

- Note 1:** Polarity control bits HPOL and LPOL define PWM signal output active and inactive states, PWM states generated by the fault inputs or PWM manual override.
- 2:** PWM6 and PWM7 output channels are only available on the PIC18F4X21 devices.
- 3:** When PWMPIN = 0, PWMEN<2:0> = 101 if device has eight PWM output pins (40 and 44-pin devices) and PWMEN<2:0> = 100 if the device has six PWM output pins (28-pin device). PWM output polarity is defined by HPOL and LPOL.
- 4:** This bit is reserved on PIC18F2X31 devices and should be maintained set (i.e., equal to '1').
- 5:** For PIC18FX431 devices only.

PIC18F2331/2431/4331/4431

TABLE 5-4: PIC18FXX31 CONFIGURATION BIT DESCRIPTIONS (CONTINUED)

Bit Name	Configuration Words	Description
MCLRE	CONFIG3H	MCLR Pin Enable bit 1 = MCLR pin enabled; RE3 input pin disabled 0 = RE3 input pin enabled; MCLR disabled
EXCLKMX ⁽⁴⁾	CONFIG3H	TMR0/GPCKI External Clock Mux bit 1 = TMR0/T5CKI external clock input is multiplexed with RC3 0 = TMR0/T5CKI external clock input is multiplexed with RD0
PWM4MX ⁽⁴⁾	CONFIG3H	PWM4 Mux bit 1 = PWM4 output is multiplexed with RB5 0 = PWM4 output is multiplexed with RD5
SSPMX ⁽⁴⁾	CONFIG3H	SSP I/O Mux bit 1 = SCK/SCL clocks and SDA/SDI data are multiplexed with RC5 and RC4, respectively. SDO output is multiplexed with RC7. 0 = SCK/SCL clocks and SDA/SDI data are multiplexed with RD3 and RD2, respectively. SDO output is multiplexed with RD1.
FLTAMX ⁽⁴⁾	CONFIG3H	FLTA Mux bit 1 = FLTA input is multiplexed with RC1 0 = FLTA input is multiplexed with RD4
BKBUG	CONFIG4L	Background Debugger Enable bit 1 = Background debugger disabled (RB6, RB7 have I/O port function) 0 = Background debugger functions enabled (RB6, RB7 have ICSP serial communication function)
LVP	CONFIG4L	Low Voltage Programming Enable bit 1 = Low voltage programming enabled 0 = Low voltage programming disabled
STVREN	CONFIG4L	Stack Overflow Reset Enable bit 1 = RESET on stack overflow/underflow enabled 0 = RESET on stack overflow/underflow disabled
CP3 ⁽⁵⁾	CONFIG5L	Code Protection bit 1 = Block 3 (003000h-003FFFh) not code protected 0 = Block 3 (003000h-003FFFh) code protected
CP2 ⁽⁵⁾	CONFIG5L	Code Protection bit 1 = Block 2 (002000h-002FFFh) not code protected 0 = Block 2 (002000h-002FFFh) code protected
CP1	CONFIG5L	Code Protection bit 1 = Block 1 (001000h-001FFFh) not code protected 0 = Block 1 (001000h-001FFFh) code protected
CP0	CONFIG5L	Code Protection bit 1 = Block 0 (000200h-000FFFh) not code protected 0 = Block 0 (000200h-000FFFh) code protected

- Note 1:** Polarity control bits HPOL and LPOL define PWM signal output active and inactive states, PWM states generated by the fault inputs or PWM manual override.
- 2:** PWM6 and PWM7 output channels are only available on the PIC18F4X21 devices.
- 3:** When PWMPIN = 0, PWMEN<2:0> = 101 if device has eight PWM output pins (40 and 44-pin devices) and PWMEN<2:0> = 100 if the device has six PWM output pins (28-pin device). PWM output polarity is defined by HPOL and LPOL.
- 4:** This bit is reserved on PIC18F2X31 devices and should be maintained set (i.e., equal to '1').
- 5:** For PIC18FX431 devices only.

PIC18F2331/2431/4331/4431

TABLE 5-4: PIC18FXX31 CONFIGURATION BIT DESCRIPTIONS (CONTINUED)

Bit Name	Configuration Words	Description
CPD	CONFIG5H	Code Protection bit Data EEPROM 1 = Data EEPROM not code protected 0 = Data EEPROM code protected
CPB	CONFIG5H	Code Protection bit 1 = Boot block (000000-0001FFh) not code protected 0 = Boot block (000000-0001FFh) code protected
WRT3 ⁽⁵⁾	CONFIG6L	Write Protection bit 1 = Block 3 (003000h-003FFFh) not write protected 0 = Block 3 (003000h-003FFFh) write protected
WRT2 ⁽⁵⁾	CONFIG6L	Write Protection bit 1 = Block 2 (002000h-002FFFh) not write protected 0 = Block 2 (002000h-002FFFh) write protected
WRT1	CONFIG6L	Write Protection bit 1 = Block 1 (001000h-001FFFh) not write protected 0 = Block 1 (001000h-001FFFh) write protected
WRT0	CONFIG6L	Write Protection bit 1 = Block 0 (000200h-000FFFh) not write protected 0 = Block 0 (000200h-000FFFh) write protected
WRD	CONFIG6H	Write Protection bit Data EEPROM 1 = Data EEPROM not write protected 0 = Data EEPROM write protected
WRTB	CONFIG6H	Write Protection bit 1 = Boot block (000000h-0001FFh) not write protected 0 = Boot block (000000h-0001FFh) write protected
WRTC	CONFIG6H	Write Protection bit ⁽¹⁾ 1 = Configuration registers (300000h-3000FF) not write protected 0 = Configuration registers (300000h-3000FF) write protected

- Note 1:** Polarity control bits HPOL and LPOL define PWM signal output active and inactive states, PWM states generated by the fault inputs or PWM manual override.
- 2:** PWM6 and PWM7 output channels are only available on the PIC18F4X21 devices.
- 3:** When PWMPIN = 0, PWMEN<2:0> = 101 if device has eight PWM output pins (40 and 44-pin devices) and PWMEN<2:0> = 100 if the device has six PWM output pins (28-pin device). PWM output polarity is defined by HPOL and LPOL.
- 4:** This bit is reserved on PIC18F2X31 devices and should be maintained set (i.e., equal to '1').
- 5:** For PIC18FX431 devices only.

PIC18F2331/2431/4331/4431

TABLE 5-4: PIC18FXX31 CONFIGURATION BIT DESCRIPTIONS (CONTINUED)

Bit Name	Configuration Words	Description
EBTR3 ⁽⁵⁾	CONFIG7L	Table Read Protection bit 1 = Block 3 (003000h-003FFFh) not protected from table reads executed in other blocks 0 = Block 3 (003000h-003FFFh) protected from table reads executed in other blocks
EBTR2 ⁽⁵⁾	CONFIG7L	Table Read Protection bit 1 = Block 2 (002000h-002FFFh) not protected from table reads executed in other blocks 0 = Block 2 (002000h-002FFFh) protected from table reads executed in other blocks
EBTR1	CONFIG7L	Table Read Protection bit 1 = Block 1 (001000h-001FFFh) not protected from table reads executed in other blocks 0 = Block 1 (001000h-001FFFh) protected from table reads executed in other blocks
EBTR0	CONFIG7L	Table Read Protection bit 1 = Block 0 (000200h-000FFFh) not protected from table reads executed in other blocks 0 = Block 0 (000200h-000FFFh) protected from table reads executed in other blocks
EBTRB	CONFIG7H	Table Read Protection bit 1 = Boot block (000000h-0001FFh) not protected from table reads executed in other blocks 0 = Boot block (000000h-0001FFh) protected from table reads executed in other blocks
DEV<2:0>	DEVID1	Device ID bits These bits are used with the DEV<10:3> bits in the Device ID Register 2 to identify the part number.
REV<4:0>	DEVID1	Revision ID bits These bits are used to indicate the device revision.
DEV<10:3>	DEVID2	Device ID bits These bits are used with the DEV<2:0> bits in the Device ID Register 1 to identify the part number.

- Note 1:** Polarity control bits HPOL and LPOL define PWM signal output active and inactive states, PWM states generated by the fault inputs or PWM manual override.
- 2:** PWM6 and PWM7 output channels are only available on the PIC18F4X21 devices.
- 3:** When PWMPIN = 0, PWMEN<2:0> = 101 if device has eight PWM output pins (40 and 44-pin devices) and PWMEN<2:0> = 100 if the device has six PWM output pins (28-pin device). PWM output polarity is defined by HPOL and LPOL.
- 4:** This bit is reserved on PIC18F2X31 devices and should be maintained set (i.e., equal to '1').
- 5:** For PIC18FX431 devices only.

5.4 Embedding Configuration Word Information in the HEX File

To allow portability of code, a PIC18FXX31 programmer is required to read the configuration word locations from the HEX file. If configuration word information is not present in the HEX file, then a simple warning message should be issued. Similarly, while saving a HEX file, all configuration word information must be included. An option to not include the configuration word information may be provided. When embedding configuration word information in the HEX file, it should start at address 300000h.

Microchip Technology Inc. feels strongly that this feature is important for the benefit of the end customer.

5.5 Checksum Computation

The checksum is calculated by summing the following:

- The contents of all code memory locations
- The configuration word, appropriately masked
- ID locations

The Least Significant 16 bits of this sum are the checksum.

Table 5-5 (pages 34 through 36) describes how to calculate the checksum for each device.

Note 1: The checksum calculation differs depending on the code protect setting. Since the code memory locations read out differently depending on the code protect setting, the table describes how to manipulate the actual code memory values to simulate the values that would be read from a protected device. When calculating a checksum by reading a device, the entire code memory can simply be read and summed. The configuration word and ID locations can always be read.

PIC18F2331/2431/4331/4431

TABLE 5-5: CHECKSUM COMPUTATION

Device	Code Protect	Checksum	Blank Value	0xAA at 0 and Max Address
PIC18F2331	None	SUM(0000:01FF)+SUM(0200:0FFF)+SUM(1000:1FFF)+ (CONFIG0 & 0000)+(CONFIG1 & 00CF)+(CONFIG2 & 000F)+ (CONFIG3 & 003F)+(CONFIG4 & 003C)+(CONFIG5 & 009D)+ (CONFIG6 & 0085)+(CONFIG7 & 0000)+(CONFIG8 & 0003)+ (CONFIG9 & 00C0)+(CONFIG10 & 0003)+(CONFIG11 & 00E0)+ (CONFIG12 & 0003)+(CONFIG13 & 0040)	E464	E3BA
	Boot Block	SUM(0200:0FFF)+SUM(1000:1FFF)+(CONFIG0 & 0000)+ (CONFIG1 & 00CF)+(CONFIG2 & 000F)+(CONFIG3 & 003F)+ (CONFIG4 & 003C)+(CONFIG5 & 009D)+(CONFIG6 & 0085)+ (CONFIG7 & 0000)+(CONFIG8 & 0003)+(CONFIG9 & 00C0)+ (CONFIG10 & 0003)+(CONFIG11 & 00E0)+(CONFIG12 & 0003)+ (CONFIG13 & 0040)+SUM(IDs)	E640	E5F5
	Boot Block/ Block 0	(CONFIG0 & 0000)+(CONFIG1 & 00CF)+(CONFIG2 & 000F)+ (CONFIG3 & 003F)+(CONFIG4 & 003C)+(CONFIG5 & 009D)+ (CONFIG6 & 0085)+(CONFIG7 & 0000)+(CONFIG8 & 0003)+ (CONFIG9 & 00C0)+(CONFIG10 & 0003)+(CONFIG11 & 00E0)+ (CONFIG12 & 0003)+(CONFIG13 & 0040)+SUM(IDs)	043D	0447
	All	(CONFIG0 & 0000)+(CONFIG1 & 00CF)+(CONFIG2 & 000F)+ (CONFIG3 & 003F)+(CONFIG4 & 003C)+(CONFIG5 & 009D)+ (CONFIG6 & 0085)+(CONFIG7 & 0000)+(CONFIG8 & 0003)+ (CONFIG9 & 00C0)+(CONFIG10 & 0003)+(CONFIG11 & 00E0)+ (CONFIG12 & 0003)+(CONFIG13 & 0040)+SUM(IDs)	043D	0447

Legend: Item Description
 CFGW = Configuration Word
 SUM[a:b] = Sum of locations, a to b inclusive
 SUM_ID = Byte-wise sum of lower four bits of all customer ID locations
 + = Addition
 & = Bit-wise AND

PIC18F2331/2431/4331/4431

TABLE 5-5: CHECKSUM COMPUTATION (CONTINUED)

Device	Code Protect	Checksum	Blank Value	0xAA at 0 and Max Address
PIC18F2431	None	SUM(0000:01FF)+SUM(0200:0FFF)+SUM(1000:1FFF)+SUM(2000:2FFF)+SUM(3000:3FFF)+(CONFIG0 & 0000)+(CONFIG1 & 00CF)+(CONFIG2 & 000F)+(CONFIG3 & 003F)+(CONFIG4 & 003C)+(CONFIG5 & 009D)+(CONFIG6 & 0085)+(CONFIG7 & 0000)+(CONFIG8 & 000F)+(CONFIG9 & 00C0)+(CONFIG10 & 000F)+(CONFIG11 & 00E0)+(CONFIG12 & 000F)+(CONFIG13 & 0040)	C488	C3DE
	Boot Block	SUM(0200:0FFF)+SUM(1000:1FFF)+SUM(2000:2FFF)+SUM(3000:3FFF)+(CONFIG0 & 0000)+(CONFIG1 & 00CF)+(CONFIG2 & 000F)+(CONFIG3 & 003F)+(CONFIG4 & 003C)+(CONFIG5 & 009D)+(CONFIG6 & 0085)+(CONFIG7 & 0000)+(CONFIG8 & 000F)+(CONFIG9 & 00C0)+(CONFIG10 & 000F)+(CONFIG11 & 00E0)+(CONFIG12 & 000F)+(CONFIG13 & 0040)+SUM(IDs)	C668	C61D
	Boot Block/ Block 0	SUM(2000:2FFF)+SUM(3000:3FFF)+(CONFIG0 & 0000)+(CONFIG1 & 00CF)+(CONFIG2 & 000F)+(CONFIG3 & 003F)+(CONFIG4 & 003C)+(CONFIG5 & 009D)+(CONFIG6 & 0085)+(CONFIG7 & 0000)+(CONFIG8 & 000F)+(CONFIG9 & 00C0)+(CONFIG10 & 000F)+(CONFIG11 & 00E0)+(CONFIG12 & 000F)+(CONFIG13 & 0040)+SUM(IDs)	E465	E41A
	All	(CONFIG0 & 0000)+(CONFIG1 & 00CF)+(CONFIG2 & 000F)+(CONFIG3 & 003F)+(CONFIG4 & 003C)+(CONFIG5 & 009D)+(CONFIG6 & 0085)+(CONFIG7 & 0000)+(CONFIG8 & 000F)+(CONFIG9 & 00C0)+(CONFIG10 & 000F)+(CONFIG11 & 00E0)+(CONFIG12 & 000F)+(CONFIG13 & 0040)+SUM(IDs)	0459	0463

Legend: Item Description
 CFGW = Configuration Word
 SUM[a:b] = Sum of locations, a to b inclusive
 SUM_ID = Byte-wise sum of lower four bits of all customer ID locations
 + = Addition
 & = Bit-wise AND

PIC18F2331/2431/4331/4431

TABLE 5-5: CHECKSUM COMPUTATION (CONTINUED)

Device	Code Protect	Checksum	Blank Value	0xAA at 0 and Max Address
PIC18F4331	None	SUM(0000:01FF)+SUM(0200:0FFF)+SUM(1000:1FFF)+ (CONFIG0 & 0000)+(CONFIG1 & 00CF)+(CONFIG2 & 000F)+ (CONFIG3 & 003F)+(CONFIG4 & 003C)+(CONFIG5 & 009D)+ (CONFIG6 & 0085)+(CONFIG7 & 0000)+(CONFIG8 & 0003)+ (CONFIG9 & 0003)+(CONFIG10 & 00E0)+(CONFIG11 & 0003)+ (CONFIG12 & 0040)+(CONFIG13 & 0000)	E3A4	E2FA
	Boot Block	SUM(0200:0FFF)+SUM(1000:1FFF)+(CONFIG0 & 0000)+ (CONFIG1 & 00CF)+(CONFIG2 & 000F)+(CONFIG3 & 003F)+ (CONFIG4 & 003C)+(CONFIG5 & 009D)+(CONFIG6 & 0085)+ (CONFIG7 & 0000)+(CONFIG8 & 0003)+(CONFIG9 & 0003)+ (CONFIG10 & 00E0)+(CONFIG11 & 0003)+(CONFIG12 & 0040)+ (CONFIG13 & 0000)+SUM(IDs)	E5C3	E578
	Boot Block/ Block 0/ Block 1	(CONFIG0 & 0000)+(CONFIG1 & 00CF)+(CONFIG2 & 000F)+ (CONFIG3 & 003F)+(CONFIG4 & 003C)+(CONFIG5 & 009D)+ (CONFIG6 & 0085)+(CONFIG7 & 0000)+(CONFIG8 & 0003)+ (CONFIG9 & 0003)+(CONFIG10 & 00E0)+(CONFIG11 & 0003)+ (CONFIG12 & 0040)+(CONFIG13 & 0000)+SUM(IDs)	03C0	03CA
	All	(CONFIG0 & 0000)+(CONFIG1 & 00CF)+(CONFIG2 & 000F)+ (CONFIG3 & 003F)+(CONFIG4 & 003C)+(CONFIG5 & 009D)+ (CONFIG6 & 0085)+(CONFIG7 & 0000)+(CONFIG8 & 0003)+ (CONFIG9 & 0003)+(CONFIG10 & 00E0)+(CONFIG11 & 0003)+ (CONFIG12 & 0040)+(CONFIG13 & 0000)+SUM(IDs)	03C0	03CA

Legend: Item Description
 CFGW = Configuration Word
 SUM[a:b] = Sum of locations, a to b inclusive
 SUM_ID = Byte-wise sum of lower four bits of all customer ID locations
 + = Addition
 & = Bit-wise AND

PIC18F2331/2431/4331/4431

TABLE 5-5: CHECKSUM COMPUTATION (CONTINUED)

Device	Code Protect	Checksum	Blank Value	0xAA at 0 and Max Address
PIC18F4431	None	SUM(0000:01FF)+SUM(0200:0FFF)+SUM(1000:1FFF)+SUM(2000:2FFF)+SUM(3000:3FFF)+(CONFIG0 & 0000)+(CONFIG1 & 00CF)+(CONFIG2 & 000F)+(CONFIG3 & 003F)+(CONFIG4 & 003C)+(CONFIG5 & 009D)+(CONFIG6 & 0085)+(CONFIG7 & 0000)+(CONFIG8 & 000F)+(CONFIG9 & 00C0)+(CONFIG10 & 000F)+(CONFIG11 & 00E0)+(CONFIG12 & 000F)+(CONFIG13 & 0040)	C488	C3DE
	Boot Block	SUM(0200:0FFF)+SUM(1000:1FFF)+SUM(2000:2FFF)+SUM(3000:3FFF)+(CONFIG0 & 0000)+(CONFIG1 & 00CF)+(CONFIG2 & 000F)+(CONFIG3 & 003F)+(CONFIG4 & 003C)+(CONFIG5 & 009D)+(CONFIG6 & 0085)+(CONFIG7 & 0000)+(CONFIG8 & 000F)+(CONFIG9 & 00C0)+(CONFIG10 & 000F)+(CONFIG11 & 00E0)+(CONFIG12 & 000F)+(CONFIG13 & 0040)+SUM(IDs)	C668	C61D
	Boot Block/ Block 0/ Block 1	SUM(2000:2FFF)+SUM(3000:3FFF)+(CONFIG0 & 0000)+(CONFIG1 & 00CF)+(CONFIG2 & 000F)+(CONFIG3 & 003F)+(CONFIG4 & 003C)+(CONFIG5 & 009D)+(CONFIG6 & 0085)+(CONFIG7 & 0000)+(CONFIG8 & 000F)+(CONFIG9 & 00C0)+(CONFIG10 & 000F)+(CONFIG11 & 00E0)+(CONFIG12 & 000F)+(CONFIG13 & 0040)+SUM(IDs)	E465	E41A
	All	(CONFIG0 & 0000)+(CONFIG1 & 00CF)+(CONFIG2 & 000F)+(CONFIG3 & 003F)+(CONFIG4 & 003C)+(CONFIG5 & 009D)+(CONFIG6 & 0085)+(CONFIG7 & 0000)+(CONFIG8 & 000F)+(CONFIG9 & 00C0)+(CONFIG10 & 000F)+(CONFIG11 & 00E0)+(CONFIG12 & 000F)+(CONFIG13 & 0040)+SUM(IDs)	0459	0463

Legend: Item Description
 CFGW = Configuration Word
 SUM[a:b] = Sum of locations, a to b inclusive
 SUM_ID = Byte-wise sum of lower four bits of all customer ID locations
 + = Addition
 & = Bit-wise AND

5.6 Embedding Data EEPROM Information In the HEX File

To allow portability of code, a PIC18FXX31 programmer is required to read the data EEPROM information from the HEX file. If data EEPROM information is not present, a simple warning message should be issued. Similarly, when saving a HEX file, all data EEPROM information must be included. An option to not include the data EEPROM information may be provided. When embedding data EEPROM information in the HEX file, it should start at address F00000h.

Microchip Technology Inc. believes that this feature is important for the benefit of the end customer.

PIC18F2331/2431/4331/4431

6.0 AC/DC CHARACTERISTICS TIMING REQUIREMENTS FOR PROGRAM/VERIFY TEST MODE

Standard Operating Conditions						
Operating Temperature: 10°C to 50°C unless otherwise indicated						
Param No.	Sym	Characteristic	Min	Max	Units	Conditions
D110	VIHH	High Voltage Programming Voltage on MCLR/VPP	9.00	13.25	V	
D110A	VIHL	Low Voltage Programming Voltage on MCLR/VPP	2.00	5.50	V	
D111	VDD	Supply Voltage during programming	2.00	5.50	V	Normal programming
			4.50	5.50	V	Bulk erase operations
D112	IPP	Programming Current on MCLR/VPP	—	300	μA	
D113	IDDP	Supply Current during programming	—	5	mA	
D031	VIL	Input Low Voltage	VSS	0.2 VSS	V	
D041	VIH	Input High Voltage	0.8 VDD	VDD	V	
D080	VOL	Output Low Voltage	—	0.6	V	IOL = 8.5 mA
D090	VOH	Output High Voltage	VDD - 0.7	—	V	IOH = -3.0 mA
D012	CIO	Capacitive Loading on I/O pin (SDATA)	—	50	pF	To meet AC specifications
P2	Tsclk	Serial Clock (SCLK) period	100	—	ns	VDD = 5.0V
			1	—	μs	VDD = 2.0V
P2A	TsclkL	Serial Clock (SCLK) Low Time	40	—	ns	VDD = 5.0V
			400	—	ns	VDD = 2.0V
P2B	TsclkH	Serial Clock (SCLK) High Time	40	—	ns	VDD = 5.0V
			400	—	ns	VDD = 2.0V
P3	Tset1	Input Data Setup Time to serial clock ↓	15	—	ns	
P4	Thld1	Input Data Hold Time from SCLK ↓	15	—	ns	
P5	Tdly1	Delay between 4-bit command and command operand	20	—	ns	
P5A	Tdly1a	Delay between 4-bit command operand and next 4-bit command	20	—	ns	
P6	Tdly2	Delay between last SCLK ↓ of command byte to first SCLK ↑ of read of data word	20	—	ns	
P9	Tdly5	SCLK High Time (minimum programming time)	1	—	ms	
P10	Tdly6	SCLK Low Time after programming (high voltage discharge time)	5	—	μs	
P11	Tdly7	Delay to allow self-timed data write or bulk erase to occur	5	—	ms	
P12	Thld2	Input Data Hold Time from MCLR/VPP ↑	2	—	μs	
P13	Tset2	VDD ↑ Setup Time to MCLR/VPP ↑	100	—	ns	
P14	Tvalid	Data Out Valid from SCLK ↑	10	—	ns	
P15	Tset3	PGM ↑ Setup Time to MCLR/VPP ↑	2	—	μs	

Note the following details of the code protection feature on Microchip devices:

- Microchip products meet the specification contained in their particular Microchip Data Sheet.
- Microchip believes that its family of products is one of the most secure families of its kind on the market today, when used in the intended manner and under normal conditions.
- There are dishonest and possibly illegal methods used to breach the code protection feature. All of these methods, to our knowledge, require using the Microchip products in a manner outside the operating specifications contained in Microchip's Data Sheets. Most likely, the person doing so is engaged in theft of intellectual property.
- Microchip is willing to work with the customer who is concerned about the integrity of their code.
- Neither Microchip nor any other semiconductor manufacturer can guarantee the security of their code. Code protection does not mean that we are guaranteeing the product as "unbreakable."

Code protection is constantly evolving. We at Microchip are committed to continuously improving the code protection features of our products. Attempts to break microchip's code protection feature may be a violation of the Digital Millennium Copyright Act. If such acts allow unauthorized access to your software or other copyrighted work, you may have a right to sue for relief under that Act.

Information contained in this publication regarding device applications and the like is intended through suggestion only and may be superseded by updates. It is your responsibility to ensure that your application meets with your specifications. No representation or warranty is given and no liability is assumed by Microchip Technology Incorporated with respect to the accuracy or use of such information, or infringement of patents or other intellectual property rights arising from such use or otherwise. Use of Microchip's products as critical components in life support systems is not authorized except with express written approval by Microchip. No licenses are conveyed, implicitly or otherwise, under any intellectual property rights.

Trademarks

The Microchip name and logo, the Microchip logo, dsPIC, KEELoQ, MPLAB, PIC, PICmicro, PICSTART, PRO MATE and PowerSmart are registered trademarks of Microchip Technology Incorporated in the U.S.A. and other countries.

FilterLab, microID, MXDEV, MXLAB, PICMASTER, SEEVAL and The Embedded Control Solutions Company are registered trademarks of Microchip Technology Incorporated in the U.S.A.

Accuron, Application Maestro, dsPICDEM, dsPICDEM.net, ECONOMONITOR, FanSense, FlexROM, fuzzyLAB, In-Circuit Serial Programming, ICSP, ICEPIC, microPort, Migratable Memory, MPASM, MPLIB, MPLINK, MPSIM, PICC, PICkit, PICDEM, PICDEM.net, PowerCal, PowerInfo, PowerMate, PowerTool, rLAB, rPIC, Select Mode, SmartSensor, SmartShunt, SmartTel and Total Endurance are trademarks of Microchip Technology Incorporated in the U.S.A. and other countries.

Serialized Quick Turn Programming (SQTP) is a service mark of Microchip Technology Incorporated in the U.S.A.

All other trademarks mentioned herein are property of their respective companies.

© 2003, Microchip Technology Incorporated, Printed in the U.S.A., All Rights Reserved.

 Printed on recycled paper.

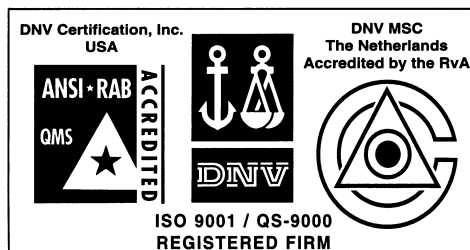

Microchip received QS-9000 quality system certification for its worldwide headquarters, design and wafer fabrication facilities in Chandler and Tempe, Arizona in July 1999 and Mountain View, California in March 2002. The Company's quality system processes and procedures are QS-9000 compliant for its PICmicro® 8-bit MCUs, KEELoQ® code hopping devices, Serial EEPROMs, microperipherals, non-volatile memory and analog products. In addition, Microchip's quality system for the design and manufacture of development systems is ISO 9001 certified.



WORLDWIDE SALES AND SERVICE

AMERICAS

Corporate Office

2355 West Chandler Blvd.
Chandler, AZ 85224-6199
Tel: 480-792-7200 Fax: 480-792-7277
Technical Support: 480-792-7627
Web Address: <http://www.microchip.com>

Atlanta

3780 Mansell Road, Suite 130
Alpharetta, GA 30022
Tel: 770-640-0034 Fax: 770-640-0307

Boston

2 Lan Drive, Suite 120
Westford, MA 01886
Tel: 978-692-3848 Fax: 978-692-3821

Chicago

333 Pierce Road, Suite 180
Itasca, IL 60143
Tel: 630-285-0071 Fax: 630-285-0075

Dallas

4570 Westgrove Drive, Suite 160
Addison, TX 75001
Tel: 972-818-7423 Fax: 972-818-2924

Detroit

Tri-Atria Office Building
32255 Northwestern Highway, Suite 190
Farmington Hills, MI 48334
Tel: 248-538-2250 Fax: 248-538-2260

Kokomo

2767 S. Albright Road
Kokomo, IN 46902
Tel: 765-864-8360 Fax: 765-864-8387

Los Angeles

18201 Von Karman, Suite 1090
Irvine, CA 92612
Tel: 949-263-1888 Fax: 949-263-1338

Phoenix

2355 West Chandler Blvd.
Chandler, AZ 85224-6199
Tel: 480-792-7966 Fax: 480-792-4338

San Jose

Microchip Technology Inc.
2107 North First Street, Suite 590
San Jose, CA 95131
Tel: 408-436-7950 Fax: 408-436-7955

Toronto

6285 Northam Drive, Suite 108
Mississauga, Ontario L4V 1X5, Canada
Tel: 905-673-0699 Fax: 905-673-6509

ASIA/PACIFIC

Australia

Microchip Technology Australia Pty Ltd
Marketing Support Division
Suite 22, 41 Rawson Street
Epping 2121, NSW
Australia
Tel: 61-2-9868-6733 Fax: 61-2-9868-6755

China - Beijing

Microchip Technology Consulting (Shanghai)
Co., Ltd., Beijing Liaison Office
Unit 915
Bei Hai Wan Tai Bldg.
No. 6 Chaoyangmen Beidajie
Beijing, 100027, No. China
Tel: 86-10-85282100 Fax: 86-10-85282104

China - Chengdu

Microchip Technology Consulting (Shanghai)
Co., Ltd., Chengdu Liaison Office
Rm. 2401-2402, 24th Floor,
Ming Xing Financial Tower
No. 88 TIDU Street
Chengdu 610016, China
Tel: 86-28-86766200 Fax: 86-28-86766599

China - Fuzhou

Microchip Technology Consulting (Shanghai)
Co., Ltd., Fuzhou Liaison Office
Unit 28F, World Trade Plaza
No. 71 Wusi Road
Fuzhou 350001, China
Tel: 86-591-7503506 Fax: 86-591-7503521

China - Hong Kong SAR

Microchip Technology Hongkong Ltd.
Unit 901-6, Tower 2, Metroplaza
223 Hing Fong Road
Kwai Fong, N.T., Hong Kong
Tel: 852-2401-1200 Fax: 852-2401-3431

China - Shanghai

Microchip Technology Consulting (Shanghai)
Co., Ltd.
Room 701, Bldg. B
Far East International Plaza
No. 317 Xian Xia Road
Shanghai, 200051
Tel: 86-21-6275-5700 Fax: 86-21-6275-5060

China - Shenzhen

Microchip Technology Consulting (Shanghai)
Co., Ltd., Shenzhen Liaison Office
Rm. 1812, 18/F, Building A, United Plaza
No. 5022 Binhe Road, Futian District
Shenzhen 518033, China
Tel: 86-755-82901380 Fax: 86-755-8295-1393

China - Qingdao

Rm. B505A, Fullhope Plaza,
No. 12 Hong Kong Central Rd.
Qingdao 266071, China
Tel: 86-532-5027355 Fax: 86-532-5027205

India

Microchip Technology Inc.
India Liaison Office
Marketing Support Division
Divyasree Chambers
1 Floor, Wing A (A3/A4)
No. 11, O'Shaughnessy Road
Bangalore, 560 025, India
Tel: 91-80-2290061 Fax: 91-80-2290062

Japan

Microchip Technology Japan K.K.
Benex S-1 6F
3-18-20, Shinyokohama
Kohoku-Ku, Yokohama-shi
Kanagawa, 222-0033, Japan
Tel: 81-45-471-6166 Fax: 81-45-471-6122

Korea

Microchip Technology Korea
168-1, Youngbo Bldg. 3 Floor
Samsung-Dong, Kangnam-Ku
Seoul, Korea 135-882
Tel: 82-2-554-7200 Fax: 82-2-558-5932 or
82-2-558-5934

Singapore

Microchip Technology Singapore Pte Ltd.
200 Middle Road
#07-02 Prime Centre
Singapore, 188980
Tel: 65-6334-8870 Fax: 65-6334-8850

Taiwan

Microchip Technology (Barbados) Inc.,
Taiwan Branch
11F-3, No. 207
Tung Hua North Road
Taipei, 105, Taiwan
Tel: 886-2-2717-7175 Fax: 886-2-2545-0139

EUROPE

Austria

Microchip Technology Austria GmbH
Durisolstrasse 2
A-4600 Wels
Austria
Tel: 43-7242-2244-399
Fax: 43-7242-2244-393

Denmark

Microchip Technology Nordic ApS
Regus Business Centre
Lautrup høj 1-3
Ballerup DK-2750 Denmark
Tel: 45-4420-9895 Fax: 45-4420-9910

France

Microchip Technology SARL
Parc d'Activite du Moulin de Massy
43 Rue du Saule Trapu
Batiment A - 1er Etage
91300 Massy, France
Tel: 33-1-69-53-63-20 Fax: 33-1-69-30-90-79

Germany

Microchip Technology GmbH
Steinheilstrasse 10
D-85737 Ismaning, Germany
Tel: 49-89-627-144-0
Fax: 49-89-627-144-44

Italy

Microchip Technology SRL
Via Quasimodo, 12
20025 Legnano (MI)
Milan, Italy
Tel: 39-0331-742611 Fax: 39-0331-466781

Netherlands

Microchip Technology Netherlands
P. A. De Biesbosch 14
NL-5152 SC Drunen, Netherlands
Tel: 31-416-690399 Fax: 31-416-690340

United Kingdom

Microchip Ltd.
505 Eskdale Road
Winnersh Triangle
Wokingham
Berkshire, England RG41 5TU
Tel: 44-118-921-5869 Fax: 44-118-921-5820

07/10/03